

RICHLAND COUNTY

REGULAR SESSION

AGENDA



TUESDAY NOVEMBER 01, 2022

6:00 PM

COUNCIL CHAMBERS

Richland County Council 2021-2022



Deirek Pugh
District 2



Bill Malinowski
District 1



Overture Walker
District 8
Chair



Gretchen Barron
District 7



Yvonne McBride
District 3



Chakisse Newton
District 11



Allison Terracio
District 5



Paul Livingston
District 4



Cheryl English
District 10



Joe Walker, III
District 6

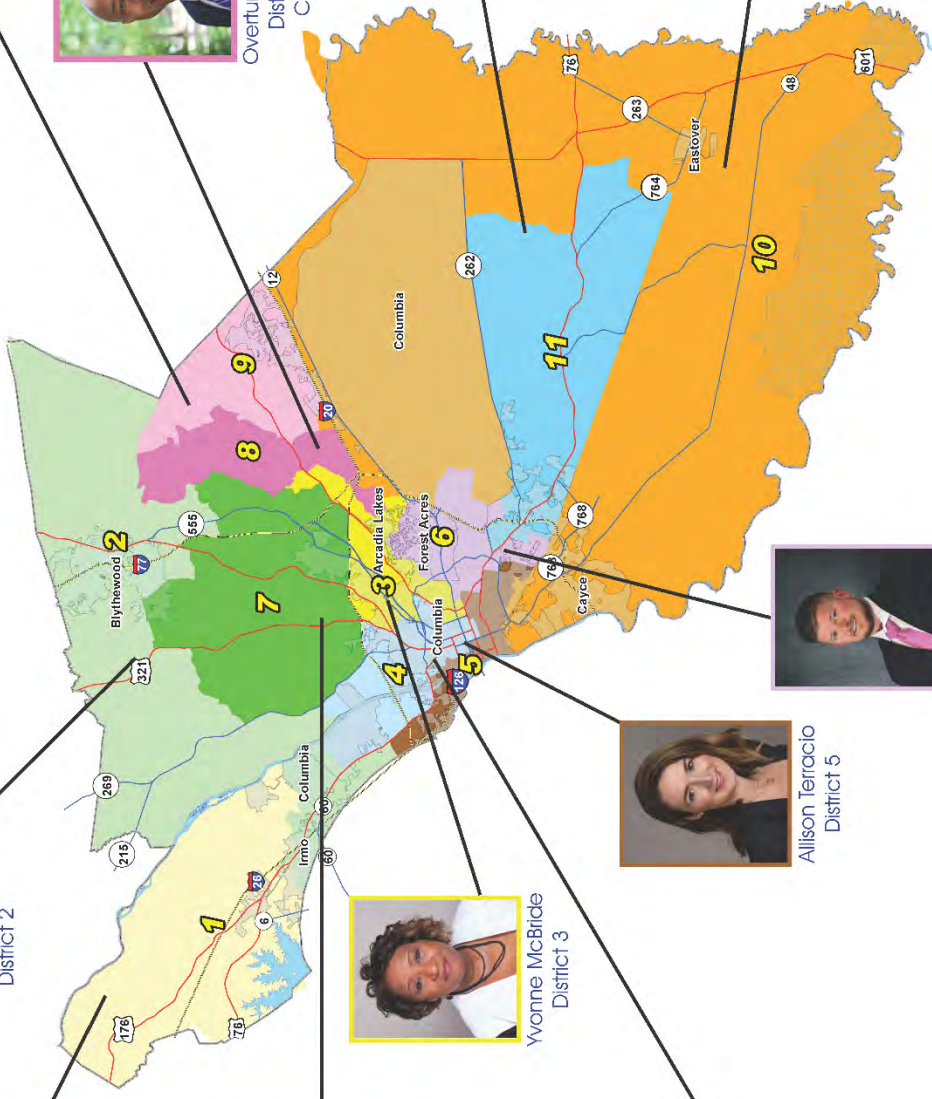



**Richland County
Regular Session**

AGENDA

November 01, 2022 - 6:00 PM
Council Chambers
2020 Hampton Street, Columbia, SC 29204

1. **CALL TO ORDER** The Honorable Overture Walker,
Chair Richland County Council
 - a. ROLL CALL
2. **INVOCATION** The Honorable Cheryl English
3. **PLEDGE OF ALLEGIANCE** The Honorable Cheryl English
4. **APPROVAL OF MINUTES** The Honorable Overture Walker
 - a. Regular Session: October 18, 2022 [PAGES 10-15]
 - b. Zoning Public Hearing: October 25, 2022 [PAGES 16-19]
 - c. Special Called Meeting: October 25, 2022 [PAGES 20-21]
5. **ADOPTION OF AGENDA** The Honorable Overture Walker
6. **REPORT OF THE ATTORNEY FOR EXECUTIVE SESSION ITEMS** Patrick Wright,
County Attorney

After Council returns to open session, council may take action on any item, including any subsection of any section, listed on an executive session agenda or discussed in an executive session during a properly noticed meeting.
7. **CITIZEN'S INPUT** The Honorable Overture Walker
 - a. For Items on the Agenda Not Requiring a Public Hearing
8. **CITIZEN'S INPUT** The Honorable Overture Walker
 - a. Must Pertain to Richland County Matters Not on the Agenda (Items for which a public hearing is required or a public hearing has been scheduled cannot be addressed at this time.)

9. REPORT OF THE COUNTY ADMINISTRATOR

Leonardo Brown,
County Administrator

- a. Updates

10. REPORT OF THE CLERK OF COUNCIL

Anette Kirylo,
Clerk of Council

- a. Strategic Planning Forum (Annual Council Retreat): January 25-27, 2023

11. REPORT OF THE CHAIR

The Honorable Overture Walker

12. OPEN / CLOSE PUBLIC HEARINGS

The Honorable Overture Walker

- a. An Ordinance Amending the Richland County Code of Ordinances, Chapter 2, Administration; Article II, County Council; Section 2-14, Compensation of Council Members; so as to reflect the new annual salary for County Council
- b. Developing a multi-county park with Fairfield County; authorizing the execution and delivery of an agreement governing the multi-county park; authorizing the inclusion of certain property located in Richland County in the multi-county park; authorizing the execution of an intergovernmental agreement; and other related matters

13. APPROVAL OF CONSENT ITEMS

The Honorable Overture Walker

- a. 22-023MA
Gerald A. Lee
RS-MD to RM-MD (3.12 Acres)
W/S Archie Drive
TMS # R17116-01-01 [SECOND READING] [PAGES 22-23]
- b. 22-016MA
John Stephenson
M-1 to RS-LD (138.5 Acres)
B/S Longwood Road
TMS # R18900-02-01 [SECOND READING] [PAGES 24-25]
- c. 22-029MA
Douglas Putlock
NC to RS-MD (3 Acres)
1012 Bickly Road
TMS # R02415-02-01 [SECOND READING] [PAGES 26-27]
- d. 22-032MA
Ervin Capers
HI to RU (4.86 Acres)

203 & 217 Gatehill Road & E/S McCords Ferry Rd.
TMS # R38800-02-09, R38900-03-06 and R38900-03-07
[SECOND READING] [PAGES 28-29]

- e. Community Planning & Development - Building Inspections - South Carolina Building Codes Council Mandated 2021 Code Cycle [PAGES 30-161]
- f. Department of Public Works – Engineering Division - Comprehensive Transportation Improvement Plan (CTIP) budget and proposed projects for Fiscal Year 2023 (FY-23) [PAGES 162-183]
- g. Move to direct the County Administrator to evaluate current zoning laws that permit zoning designations for large residential developments to remain in perpetuity and present options to re-evaluate and or rezone those properties if they are not developed within 7 years. Recommendations should include processes to ensure that zoning and the comprehensive plan remain consistent with the lived character of the community [Newton - July 13, 2021] [PAGE 184]
- h. Based on the below information, the matter of urban heat mapping should be referred to the Planning Commission for consideration. The expanding residential, commercial and transportation infrastructure contribute to areas where temperatures are much warmer, and that could put people at risk of injury or death on hot days.

“This study will help demonstrate to local governments and others where we need to preserve undeveloped land and trees, plant additional trees or build other green infrastructure to reduce or prevent heat islands in Richland County,” (Quinton) Epps said. (Division Manager, Community Planning and Development Department)

The heat-mapping initiative aims to improve understanding of and guide action to reduce heat health risks, encourage economic development and boost the area’s quality of life overall, therefore, prior to council deciding what zoning needs to be placed in specific areas without having that information would be a dereliction of our duties to the residents of the county. [Malinowski - August 30, 2022] [PAGE 185]

- i. Department of Public Works - Engineering Division - Summit Ridge/Summit Parkway Project [PAGES 186-191]
- j. Utilities Department - Engineering Services for the Design and Construction of an Elevated Water Tank [PAGES 192-196]

- k. Department of Public Works - Engineering Division -Little Jackson Creek Upditch Improvement Project
[PAGES 197-208]
- l. Direct the County Administrator to look into what it will take to have Richland County CASA receive state funding to operate the way that all other CASA groups in the state do, with state funding. Richland County should not be excluded from something that is provided to all other counties by the state. [MALINOWSKI - May 3, 2022]
[PAGES 209-210]

14. THIRD READING ITEMS

The Honorable Overture Walker

- a. 22-006MA
Jared Munneke
GC/M-1/RU/RM-HD to RM-HD (74.28 Acres)
End of Idlewilde Boulevard and Barnes Street
TMS# R11111-01-02, 54 & 55, R11114-01-02 & 13
[PAGES 211-212]
- b. Developing a multi-county park with Fairfield County; authorizing the execution and delivery of an agreement governing the multi-county park; authorizing the inclusion of certain property located in Richland County in the multi-county park; authorizing the execution of an intergovernmental agreement; and other related matters
[PAGES 213-238]
- c. An Ordinance Amending the Richland County Code of Ordinances, Chapter 2, Administration; Article II, County Council; Section 2-14, Compensation of Council Members; so as to reflect the new annual salary for County Council [PAGES 239-240]

15. REPORT OF ADMINISTRATION & FINANCE COMMITTEE

The Honorable Bill Malinowski

- a. Department of Public Works - Solid Waste & Recycling - Articulated Dump Truck [PAGES 241-254]

16. REPORT OF ECONOMIC DEVELOPMENT COMMITTEE

The Honorable Paul Livingston

- a. Committing to negotiate a fee-in-lieu of ad valorem taxes agreement between Richland County and Project Wellness; identifying the project; and other matters related thereto [PAGES 255-256]
- b. Authorizing the execution and delivery of a fee-in-lieu of ad valorem taxes and incentive agreement by and between Richland County, South Carolina and Project Wellness to provide for payment of a fee-in-lieu of taxes;

**17. REPORT OF RULES & APPOINTMENTS
COMMITTEE**

a. NOTIFICATION OF APPOINTMENTS

1. Central Midlands Council of Governments Board (CMCOG) - One (1) Vacancy
 - a. Susan Brill
 - b. Gethro Benn
 - c. Edward Frazier
 - d. Carol DuBose
 - e. Tammie Greene
 - f. Andrew Williamson
 - g. Ann Maletic
 - h. Chelsea Richard
2. Airport Commission - One (1) Vacancy
 - a. Kevin Bland
 - b. D. Michael Kelly (*Incumbent)
 - c. Edward Frazier
 - d. Patrick Belton
 - e. Brian Gwin
 - f. Carol D. Tyler
 - g. Frank Caggiano
3. Board of Zoning Appeals - Six (6) Vacancies
 - a. Julius Givens
 - b. Carol R. DuBose
 - c. David Fulmer

d. Shasai Hendrix

e. Timothy
Brown

f. Brian Harbison

b. ITEMS FOR ACTION

1. Review of Comprehensive Council Rules
[PAGES 292-319]

2. Internal Audit Position [PAGE 320]

18. REPORT OF THE COMMUNITY IMPACT GRANTS COMMITTEE

The Honorable Cheryl English

a. Criteria, Application and Schedule for Community
Impact Grant Funds [PAGES 321-342]

19. OTHER ITEMS

The Honorable Overture Walker

a. A Resolution to appoint and commission Michael Brent
Davis as a Code Enforcement Officer for the proper
security, general welfare, and convenience of Richland
County [PAGE 343]

20. EXECUTIVE SESSION

Patrick Wright,
County Attorney

*After Council returns to open session, council may take action on any item,
including any subsection of any section, listed on an executive session
agenda or discussed in an executive session during a properly noticed
meeting.*

21. MOTION PERIOD

22. ADJOURNMENT

The Honorable Overture Walker



Special Accommodations and Interpreter Services Citizens may be present during any of the County's meetings. If requested, the agenda and backup materials will be made available in alternative formats to persons with a disability, as required by Section 202 of the Americans with Disabilities Act of 1990 (42 U.S.C. Sec. 12132), as amended and the federal rules and regulations adopted in implementation thereof. Any person who requires a disability-related modification or accommodation, including auxiliary aids or services, in order to participate in the public meeting may request such modification, accommodation, aid or service by contacting the Clerk of Council's office either in person at 2020 Hampton Street, Columbia, SC, by telephone at (803) 576-2061, or TDD at 803-576-2045 no later than 24 hours prior to the scheduled meeting.



Richland County Council
REGULAR SESSION
MINUTES
October 18, 2022 – 6:00 PM
Council Chambers
2020 Hampton Street, Columbia, SC 29204

COUNCIL MEMBERS PRESENT: Overture Walker, Chair; Jesica Mackey, Vice-Chair; Bill Malinowski, Derrek Pugh, Yvonne McBride, Allison Terracio, Joe Walker, Gretchen Barron, Overture Walker, Cheryl English and Chakisse Newton

OTHERS PRESENT: Michelle Onley, Jennifer Wladischkin, Kyle Holsclaw, Judy Carter, Michael Byrd, Angela Weathersby, Justin Landy, Dale Welch, Geo Price, Michael Maloney, Brittney Terry-Hoyle, Dante Roberts, Aric Jensen, Chanda Cooper, Quinton Epps, Patrick Wright, Leonardo Brown, Anette Kirylo, Sandra Haynes, Tamar Black, Casey White, Susan O’Cain, Chelsea Bennett, Jeff Ruble and Dwight Hanna

1. **CALL TO ORDER** – Chairman Overture Walker called the meeting to order at approximately 6:00 PM.
2. **INVOCATION** – The Invocation was led by the Honorable Joe Walker.
3. **PLEDGE OF ALLEGIANCE** – The Pledge of Allegiance was led by the Honorable Joe Walker.
4. **PRESENTATION OF PROCLAMATION**
 - a. Family Court Awareness Month Proclamation – Ms. English, Ms. Barron, Ms. Mackey, Ms. McBride and Mr. Pugh presented a proclamation in honor of Family Court Awareness Month.
 - b. Family Literacy Month Proclamation – Ms. Barron presented a proclamation in honor of Family Literacy Month.

POINT OF PERSONAL PRIVILEGE – Ms. Mackey acknowledged that Mr. Derrick Huggins, the COMET’s Interim CEO, passed away. She recognized all of Mr. Huggins contributions to Richland County and the community.

5. **PRESENTATION**
 - a. Soil and Water Conservation District Commission Annual Report – Mr. Kenneth Mullis, Chairman, Soil and Water Conservation District Commission, presented their annual report to Council.
6. **APPROVAL OF MINUTES**
 - a. Regular Session: October 4, 2022 – Mr. Livingston moved to approve the minutes as distributed, seconded by Mr. Pugh.

Mr. Malinowski noted the documents included in the September 27th Zoning Public Hearing minutes were provided to Council members, but not the public. In addition, his vote was recorded incorrectly on Item 20(d): “Bull St/Elmwood Avenue Intersection – Award of Contract”. The record needs to reflect he voted against this item.

Ms. Newton indicated her vote on Item 20(c): “Wetland Credit Sales” was recorded incorrectly. She voted “nay”.

Mr. Malinowski made a substitute motion to approve the minutes as corrected, seconded by Ms. Newton.

In Favor: Malinowski, Pugh, McBride, Livingston, Terracio, J. Walker, Barron, O. Walker, Mackey, English and Newton

The vote in favor was unanimous.

**Regular Session
October 18, 2022**

7. **ADOPTION OF AGENDA** – Ms. McBride moved to adopt the agenda as published, seconded by Mr. J. Walker.

In Favor: Malinowski, Pugh, McBride, Livingston, Terracio, J. Walker, Barron, O. Walker, Mackey, English and Newton
The vote in favor was unanimous.

8. **REPORT OF THE ATTORNEY FOR EXECUTIVE SESSION ITEMS** – Mr. Patrick Wright, County Attorney, state the following item is eligible for Executive Session.

- a. Budget Process and Council Compensation

9. **CITIZENS' INPUT**

- a. For Items on the Agenda Not Requiring a Public Hearing – No one signed up to speak.

10. **CITIZENS' INPUT**

- a. Must Pertain to Richland County Matters Not on the Agenda (Items for which a public hearing is required or a public hearing has been scheduled cannot be addressed at this time) – No one signed up to speak.

11. **REPORT OF THE COUNTY ADMINISTRATOR**

- a. Coronavirus Update – Mr. Leonardo Brown, County Administrator, indicated the County is currently at Community Level Low.
- b. Allen University Property Request – 1741 Cushman Drive, Columbia, SC 29203 – Mr. Brown stated the access agreement has been submitted to Allen University. The university has the ability to go and look at the site. The item is on tonight's agenda so that Council can officially move forward with the process for considering the request.

Mr. O. Walker inquired if the request is for the soil sample or acquisition of the property.

Mr. Brown responded it is the acquisition of the soil sample. The request has already been approved by Council. He indicated to the university that a part of the process is appraisals, which have already ordered.

Ms. Barron inquired as to next steps.

Mr. Brown replied anytime you have potential acquisition of property by another entity it requires an appraisal of the property in question. You also consider any other utilization the County has for the property. The expectation is the appraisal will be available for the November 1st Council meeting.

Ms. Barron inquired as to what the request from Allen University entailed.

Mr. Brown stated the request was for a soil sample and purchase. There was not a specific amount offered. According to the County's land acquisition policy, an appraisal must be done. The property would have to be sold for at least the appraised value unless Council determines something else.

Ms. Barron stated, for clarification, the sale of the property has to be at least the appraised amount.

Mr. Brown responded Council has to consider the fair market value.

Ms. McBride stated, for clarification, there are no other actions Council can take at this time.

Mr. Brown replied he does not believe it would be appropriate at this time.

- c. Other Updates – Mr. Brown noted the County received 427 completed ARPA applications. The total requested value is \$107,117,226.87.

Ms. Mackey expressed her appreciation to staff and the Coronavirus Ad Hoc Committee on this endeavor.

Ms. McBride thanked the citizens of Richland County for applying for the grants.

12. **REPORT OF THE CLERK OF COUNCIL**

- a. Proposed 2023 Council Meeting Dates – Ms. Anette Kirylo, Clerk of Council, requested Council's consideration of the proposed 2023 Council meeting dates.

Ms. Newton inquired as to when the Council Retreat dates will be confirmed.

Ms. Kirylo responded she anticipates having the dates by the November 1st Council meeting.

**Regular Session
October 18, 2022**

-2-

Ms. Mackey moved to approve the proposed 2023 Council Meeting Calendar, seconded by Mr. J. Walker.

In Favor: Malinowski, Pugh, McBride, Livingston, Terracio, J. Walker, Barron, O. Walker, Mackey, English and Newton

The vote in favor was unanimous.

- b. Institute of Government and SCAC County Council Coalition: October 19-20, 2022 – Ms. Kirylo reminded Council members of the upcoming Institute of Government classes and SCAC County Council Coalition.

13. **REPORT OF THE CHAIR** – No report was given.

14. **OPEN/CLOSE PUBLIC HEARINGS**

- a. Authorizing the expansion of the boundaries of an industrial park jointly developed with Fairfield County to include certain property located in Richland County; the execution and delivery of an infrastructure credit agreement to provide for infrastructure credits to SE Forest Acres LLC, a company previously identified as Project Bulldog; and other related matters – No one signed up to speak.

15. **APPROVAL OF CONSENT ITEMS**

- a. 22-007MA, Lucky Detty, RM-HD to OI (.231 Acres), 116 Beatty Downs Road, TMS# R06106-01-39 [THIRD READING] – Mr. Pugh moved to approve this item, seconded by Mr. J. Walker.

In Favor: Malinowski, Pugh, McBride, Livingston, Terracio, J. Walker, Barron, O. Walker, Mackey, English and Newton

The vote in favor was unanimous.

16. **THIRD READING ITEMS**

- a. Authorizing the expansion of the boundaries of an industrial park jointly developed with Fairfield County to include certain property located in Richland County; the execution and delivery of an infrastructure credit agreement to provide for infrastructure credits to SE Forest Acres LLC, a company previously identified as Project Bulldog; and other related matters – Mr. Livingston moved to approve this item, seconded by Mr. Pugh.

In Favor: Malinowski, Pugh, McBride, Livingston, Terracio, Barron, O. Walker, English and Newton

Recuse: J. Walker (per written statement provided) and Mackey (due to her parent company representing the company)

The vote in favor was unanimous.

Mr. Livingston moved to reconsider this item, seconded by Mr. Pugh.

Opposed: Malinowski, Pugh, McBride, Livingston, Terracio, Barron, O. Walker, English and Newton

Recuse: J. Walker (per written statement provided) and Mackey (due to her parent company representing the company)

The motion for reconsideration failed.

17. **SECOND READING ITEMS**

- a. 22-006MA, Jared Munneke, GC/M-1/RU/RM-HD to RM-HD (74.28 Acres), End of Idlewilde Boulevard and Barnes Street, TMS# R11111-01-02, 54 & 55, R11114-01-02 & 13 – Ms. English moved to approve this item, seconded by Ms. Newton.

In Favor: Malinowski, Pugh, McBride, Livingston, Terracio, J. Walker, Barron, O. Walker, English and Newton

Recuse: Mackey (due to her parent company representing the applicant)

The vote in favor was unanimous.

- b. Developing a multi-county park with Fairfield County; authorizing the execution and delivery of an agreement governing the multi-county park; authorizing the inclusion of certain property located in Richland County in the multi-county park; authorizing the execution of an intergovernmental agreement; and other related matters – Mr. J. Walker moved to approve this item, seconded by Ms. Newton.

Ms. McBride requested a brief overview of this item.

Mr. Ruble stated, on the agenda tonight, is a Third Reading item, which is an agreement between the developer and the County. The Second Reading item is an agreement between the County and the City of Forest Acres. The City of Forest Acres approved Second Reading at their meeting this morning.

In Favor: Malinowski, Pugh, McBride, Livingston, Terracio, Barron, O. Walker, English and Newton

Recuse: J. Walker (per written statement provided) and Mackey (due to her parent company representing the company)

The vote in favor was unanimous.

18. FIRST READING ITEMS

- a. An Ordinance Amending the Richland County Code of Ordinances, Chapter 2, Administration; Article II, County Council; Section 2-14, Compensation of Council Members; so as to reflect the new annual salary for County Council – This item was taken up after Executive Session.

19. REPORT OF THE RULES AND APPOINTMENTS COMMITTEE

a. NOTIFICATION OF VACANCIES:

1. Accommodations Tax Committee – Seven (7) Vacancies (TWO [2] applicants must have a background in the lodging industry, THREE [3] applicants must have a background in the hospitality industry, ONE [1] applicant will fill an at-large seat)
2. Airport Commission – One (1) Vacancy (Applicant must reside in the Rosewood, Shandon or Hollywood-Rose Wales Garden neighborhoods)
3. Board of Zoning Appeals – Six (6) Vacancies
4. Building Codes Board of Appeals – Nine (9) Vacancies (ONE applicant must be from the Architecture Industry, ONE from the Gas Industry, ONE from the Building Industry, ONE from the Contracting Industry, ONE applicant must be from the Plumbing Industry, ONE applicant must be from the Electrical Industry, ONE applicant must be from the Engineering Industry and TWO from the Fire Industry, as alternates)
5. Business Service Center Appeals Board – Three (3) Vacancies (ONE [1] applicant must be from the Business Industry and TWO [2] applicants must be CPAs)
6. Community Relations Council – One (1) Vacancy
7. East Richland Public Service Commission – One (1) Vacancy
8. Hospitality Tax Committee – One (1) Vacancy (Applicant must be from the Restaurant Industry)
9. Lexington Richland Alcohol and Drug Abuse Council (LRADAC) – One (1) Vacancy
10. Midlands Workforce Development Board – Six (6) Vacancies (ONE [1] applicant must have a background in Apprenticeship, ONE [1] applicant must have a background in Adult Education, ONE [1] applicant must have a background in Education and THREE [3] applicants must be from the Private Sector)
11. Music Festival Commission – One (1) Vacancy
12. Richland Library Board – Six (6) Vacancies
13. Richland Memorial Hospital Board of Trustees – Six (6) Vacancies
14. Riverbanks Park Commission – One (1) Vacancy
15. Township Auditorium Board – Three (3) Vacancies
16. Transportation Penny Advisory Committee (TPAC) – Three (3) Vacancies

Ms. Barron stated the committee recommended advertising for the vacancies listed.

Ms. Newton inquired about the deadline for application submission.

Ms. Barron replied she believes it is November 13th, but the Clerk's Office can confirm.

**Regular Session
October 18, 2022**

-4-

In Favor: Malinowski, Pugh, McBride, Livingston, Terracio, J. Walker, Barron, O. Walker, Mackey, English and Newton

The vote in favor was unanimous.

20. **OTHER ITEMS**

- a. A Resolution to appoint and commission Eugene Jacobs as a Code Enforcement Officer for the proper security, general welfare and convenience of Richland County
- b. A Resolution to appoint and commission James Foust as a Code Enforcement Officer for the proper security, general welfare and convenience of Richland County

Mr. J. Walker moved to approve Items 20(a) and (b), seconded by Ms. Mackey.

Mr. Malinowski noted there was a scrivener's error in the resolution for Mr. Eugene Jacobs.

In Favor: Malinowski, Pugh, McBride, Livingston, Terracio, J. Walker, Barron, O. Walker, Mackey, English and Newton

The vote in favor was unanimous.

- c. Eagle View Imagery – Ms. Mackey moved to approve this item, seconded by Mr. J. Walker.

Mr. Malinowski inquired what 800 staff hours equates to in dollars. In addition, he inquired if the County needs to be concerned about privacy issues. Lastly, how much do we anticipate getting in return for our investment?

Mr. Wright stated he does not believe we have any concerns regarding privacy issues.

Mr. Brown will have a response to the questions regarding staff hours and the anticipated return on the investment prior to the minutes being approved at the next Council meeting.

In Favor: Malinowski, Pugh, McBride, Livingston, Terracio, J. Walker, Barron, O. Walker, Mackey, English and Newton

The vote in favor was unanimous.

Mr. J. Walker moved to reconsider Items 20(a) – (c), seconded by Ms. Newton.

Opposed: Malinowski, Pugh, McBride, Livingston, Terracio, J. Walker, Barron, O. Walker, Mackey, English and Newton

The motion for reconsideration failed.

21. **EXECUTIVE SESSION** – Ms. Barron moved to go into Executive Session, seconded by Mr. Livingston.

In Favor: Pugh, McBride, Livingston, Terracio, Barron, O. Walker, Mackey, English and Newton

Opposed: Malinowski and J. Walker

The vote was in favor.

***Council went into Executive Session at approximately 6:47 PM
and came out at approximately 6:56 PM***

Ms. Barron moved to come out of Executive Session, seconded by Ms. Terracio.

In Favor: Malinowski, Pugh, McBride, Livingston, Terracio, J. Walker, Barron, O. Walker, Mackey, English and Newton

The vote in favor was unanimous.

- a. Budget Process and Council Compensation – Mr. Livingston moved to amend the ordinance language as follows: "The compensation of members of the county council shall be equal to 80% of the minimum annual salary of an employee of Richland County Government. The chair of the county council shall, during his/her term as chair, receive an addition to his/her annual compensation, the sum of 10% of the annual compensation, to compensate for the additional duties..." , seconded by Ms. Barron.

Mr. Malinowski stated these funds are in the approved budget. However, during the budget process we told many entities they would have to ensure the requested amounts were equal to or less than the previous year. He believes to vote an approximate 45% increase for ourselves is out of line.

**Regular Session
October 18, 2022**

Mr. O. Walker noted, during the budget season, the Administrator put together a proposed budget. The budget included a 4% cost of living adjustment for all County employees earning a living wage. For those employees not earning a living wage, they were brought up to \$32,000. During the deliberations, the question was asked whether the Administrator's recommendation included elected officials. The question was answered in the affirmative. The action tonight does not raise the taxes of the citizens or businesses. We are memorializing the action taken during the budget process.

In Favor: Pugh, McBride, Livingston, Terracio, Barron O. Walker, Mackey and English

Opposed: Malinowski, J. Walker and Newton

The vote was in favor.

22. MOTION PERIOD

- a. I move that the 2021 Code be reviewed utilizing the 2005 Code as a base guideline to provide a new code for Richland County. It is noted staff previously stated there were some items that needed changing in the 2005 code and those items should be pointed out for addressing/changing. [MALINOWSKI] – This item was referred to the Planning Commission.

23. ADJOURNMENT – Mr. Pugh moved to adjourn the meeting, seconded by Mr. Livingston.

In Favor: Malinowski, Pugh, McBride, Livingston, Terracio, J. Walker, Barron, O. Walker, Mackey, English and Newton

The vote in favor was unanimous.

The meeting adjourned at approximately 7:04 PM.



Richland County Council
Zoning Public Hearing
MINUTES
October 25, 2022 – 7:00 PM
Council Chambers
2020 Hampton Street, Columbia, SC 29204

COUNCIL MEMBERS PRESENT: Bill Malinowski, Derrek Pugh, Yvonne McBride, Paul Livingston, Allison Terracio, Joe Walker, Gretchen Barron, Overture Walker, Jesica Mackey, Cheryl English, and Chakisse Newton

OTHERS PRESENT: Geo Price, Angela Weathersby, Justin Landy, Kyle Holsclaw, Anette Kirylo, Dale Welch, Patrick Wright, Lori Thomas, Michelle Onley, Susan O’Cain, Chelsea Bennett, Aric Jensen, Tamar Black and Tina Davis-Gooden, Andrea Hannah-Dennis.

II. **CALL TO ORDER** – Chairman Overture Walker called the meeting to order at approximately 7:00 PM.

III. **ADDITIONS/DELETIONS TO THE AGENDA**- There were no additions/deletions made to the agenda.

IV. **ADOPTION OF AGENDA** – Mr. Malinowski noted the page numbering in the agenda was not correct.

Ms. Newton noted on Case # 22-016MA the Planning Commission recommendation(s) were different on the coversheet and the agenda documentation. She inquired as to which recommendation was correct.

Mr. Price indicated the Planning Commission recommended approval.

Mr. J. Walker moved to adopt the agenda as amended, seconded by Ms. Newton.

In Favor: Malinowski, Pugh, McBride, Livingston, Terracio, J. Walker, Barron, O. Walker, Mackey, English and Newton

The vote in favor was unanimous.

V. **OPEN PUBLIC HEARING**

a. **MAP AMENDMENTS [ACTION]**

1. Case # 22-017 MA
Chandler Roy
HI to RS-MD (121.52 Acres)
E/S Farrow Road
TMS# R17600-02-32 & R17600-02-46

Mr. O. Walker opened the floor to the public hearing.

No one signed up to speak

The floor to the public hearing was closed.

Mr. Pugh moved to defer this item until the November Zoning Public Hearing, seconded by Mr. Malinowski

In Favor: Malinowski, Pugh, McBride, Livingston, Terracio, J. Walker, Barron, O. Walker, Mackey, English and Newton

The vote in favor was unanimous.

2. Case # 22-019 MA
Bill Theus
PUD to PUD (55.2 Acres)
Wilson Boulevard
TMS# R14900-04-01, R14800-02-22, R14800-02-32, R14800-02-27, R14800-02-35
and R14800-02-29

Ms. Barron moved to defer this item until the November Zoning Public Hearing, seconded by Mr. J. Walker.

In Favor: Malinowski, Pugh, McBride, Livingston, Terracio, J. Walker, Barron, O. Walker, Mackey, English, and Newton.

The motion to defer was unanimous.

3. Case # 22-021 MA
Tony Lawton
RU to GC (1.14 Acres)
113 Sease Road
TMS# R04003-02-17

Mr. O. Walker opened the floor to the public hearing.

No one signed up to speak.

The floor to the public hearing was closed.

Mr. Malinowski moved to deny the re-zoning request, seconded by Ms. Barron.

In Favor: Malinowski, Pugh, McBride, Livingston, Terracio, J. Walker, Barron, O. Walker, English, and Newton.

The vote in favor was unanimous.

4. Case # 22-022 MA
Jenny Reyes
RU to NC (8.63 Acres)
9200 Wilson Boulevard
TMS# R14600-03-41

Mr. O. Walker opened the floor to the public hearing.

No one signed up to speak.

The floor to the public hearing was closed.

Ms. Barron moved to defer this item until the November Zoning Public Hearing, seconded by Mr. Malinowski.

In Favor: Malinowski, Pugh, McBride, Livingston, Terracio, J. Walker, Barron, O. Walker, Mackey, English, and Newton.

The vote in favor was unanimous.

5. Case # 22-023 MA
Gerald A. Lee
RS-MD to RM-MD (3.12 Acres)
W/S Archie Drive
TMS# R17116-01-01

Mr. O. Walker opened the floor to the public hearing.

No one signed up to speak.

The floor to the public hearing was closed.

Ms. Barron moved to approve the rezoning request, seconded by Mr. Malinowski.

In Favor: Malinowski, Pugh, McBride, Livingston, Terracio, J. Walker, Barron, O. Walker, Mackey, English, and Newton.

The vote in favor was unanimous.

6. Case # 22-016 MA
John Stephenson
M-1 to RS-LD (138.5 Acres)
B/S Longwood Road
TMS# R18900-02-01

Mr. O. Walker opened the floor to the public hearing.

No one signed up to speak.

The floor to the public hearing was closed.

Ms. English moved to approve the rezoning request, seconded by Mr. J. Walker.

In Favor: Malinowski, Pugh, McBride, Livingston, Terracio, J. Walker Barron, O. Walker, Mackey, English, and Newton.

The vote in favor was unanimous.

7. Case # 22-028 MA
Elizabeth Swan
GC to LI (1.43 Acres)
6217 Two Notch Rd.
TMS# R14214-01-07

Mr. O. Walker opened the floor to the public hearing.

Elizabeth Swan, Robert Fuller, and Nicholas Randy Purdy spoke in favor of the rezoning request.

The floor to the public hearing was closed.

Ms. McBride moved to deny the rezoning request, seconded by Ms. Terracio.

In Favor: Malinowski, Pugh, McBride, Livingston, Terracio, J. Walker, Barron, O. Walker, Mackey, English, and Newton.

The vote in favor was unanimous.

8. Case# 22-029 MA
Douglas Putlock
NC to RS-MD (3 Acres)
1012 Bickley Road
TMS# R02415-02-01

Mr. O. Walker opened the floor to the public hearing.

No one signed up to speak

The floor to the public hearing was closed.

Mr. Malinowski moved to approve the rezoning request, seconded by Mr. Livingston

In Favor: Malinowski, Pugh, McBride, Livingston, Terracio, J. Walker, Barron, O. Walker, Mackey, English, and Newton.

The vote in favor was unanimous.

9. Case # 22-032 MA
Ervin Capers
HI to RU (4.86 Acres)
203 & 217 Gatehill Road & E/S McCords Ferry Rd.
TMS # R38800-02-09, R38900-03-06 and R38900-03-07

Mr. O. Walker opened the floor to the public hearing.

Mr. Ervin Capers spoke in favor of the rezoning request.

The floor to the public hearing was closed.

Ms. English moved to approve the rezoning request, seconded by Mr. J. Walker

In Favor: Malinowski, Pugh, McBride, Livingston, Terracio, J. Walker, Barron, O. Walker, Mackey, English and Newton

The vote in favor was unanimous.

VI. **ADJOURNMENT** – Ms. Barron moved to adjourn, seconded by Ms. English

In Favor: Malinowski, Pugh, McBride. Livingston, Terracio, J. Walker, Barron, O. Walker, Mackey, English, and Newton.

The vote in favor was unanimous.

The meeting adjourned at approximately 7:27PM.



Richland County Council
Special Called Meeting
MINUTES
October 25, 2022 – 7:40 PM
Council Chambers
2020 Hampton Street, Columbia, SC 29204

COUNCIL MEMBERS PRESENT: Overture Walker, Chair; Jesica Mackey, Vice-Chair, Bill Malinowski, Derrek Pugh, Yvonne McBride, Paul Livingston, Allison Terracio, Joe Walker Gretchen Barron, Cheryl English, and Chakisse Newton.

OTHERS PRESENT: Anette Kirylo, Leonardo Brown, Patrick Wright, Lori Thomas, Aric Jensen, Michael Byrd, Stacey Hamm, Jennifer Wladischkin, Angela Weathersby, Justin Landy, Tamar Black, Geo Price, Jeff Ruble, Dale Welch, Abhijit Deshpande, Susan O’Cain, Michelle Onley, Chelsea Bennett and Ashiya Myers.

1. **CALL TO ORDER** – Chairman Overture Walker called the meeting to order at approximately 7:40 PM.
2. **ADOPTION OF AGENDA** – Ms. Mackey moved to adopt the agenda as published, seconded by Mr. J. Walker.

In Favor: Malinowski, Pugh, McBride, Livingston, Terracio, J. Walker, Barron, O. Walker, Mackey, English and Newton.

The vote in favor was unanimous.

3. **REPORT OF ATTORNEY FOR EXECUTIVE SESSION ITEMS**

- a. **Contractual Matter: Mark Anthony Brewing, LLC**

Ms. Barron moved to go into Executive Session, seconded by Ms. McBride.

In Favor: Malinowski, Pugh, McBride, Livingston, Terracio, Barron, O. Walker, Mackey, English and Newton.

Opposed: J. Walker.

The vote was in favor.

***Council went into Executive Session at approximately 7:42 PM
and came out at approximately 7:59 PM***

Mr. Pugh moved to come out of Executive Session, seconded by Mr. Malinowski.

In Favor: Malinowski, Pugh, McBride, Livingston, Terracio, J. Walker, Barron, O. Walker, Mackey, English and Newton.

The vote in favor was unanimous.

Chairman Walker stated no actions were taken during the executive session.

4. **SECOND READING ITEMS**

- a. An Ordinance Amending the Richland County Code of Ordinances, Chapter 2, Administration; Article II, County Council; Section 2-14, Compensation of Council Members; so as to reflect the new annual salary for County Council – Mr. Livingston moved to approve this item, seconded by Ms. Barron.

Ms. Newton stated, for the record, while she supports better compensation for Council members, but she questioned this particular increase at this particular time.

In Favor: Pugh, McBride, Livingston, Terracio, Barron, O. Walker, Mackey and English .

Opposed: Malinowski, J. Walker and Newton.

The vote was in favor.

5. **ADJOURNMENT** – Mr. Livingston moved to adjourn the meeting, seconded by Ms. Barron.

In Favor: Malinowski, Pugh, McBride, Livingston, Terracio, J. Walker, Barron, O. Walker, Mackey, English.

The vote in favor was unanimous.

The meeting adjourned at approximately 8:01 PM.

Richland County Council Request for Action

Subject:

22-023MA
Gerald A. Lee
RS-MD to RM-MD (3.12 Acres)
W/S Archie Drive
TMS # R17116-01-01

Notes:

First Reading: October 25, 2022
Second Reading:
Third Reading:
Public Hearing: October 25, 2022

STATE OF SOUTH CAROLINA
COUNTY COUNCIL OF RICHLAND COUNTY
ORDINANCE NO. ____-22HR

AN ORDINANCE OF THE COUNTY COUNCIL OF RICHLAND COUNTY, SOUTH CAROLINA, AMENDING THE ZONING MAP OF UNINCORPORATED RICHLAND COUNTY, SOUTH CAROLINA, TO CHANGE THE ZONING DESIGNATION FOR THE REAL PROPERTY DESCRIBED AS TMS # R17116-01-01 FROM RESIDENTIAL SINGLE-FAMILY MEDIUM DENSITY DISTRICT (RS-MD) TO RESIDENTIAL MULTI-FAMILY MEDIUM DENSITY DISTRICT (RM-MD); AND PROVIDING FOR SEVERABILITY AND AN EFFECTIVE DATE.

Pursuant to the authority granted by the Constitution of the State of South Carolina and the General Assembly of the State of South Carolina, BE IT ENACTED BY RICHLAND COUNTY COUNCIL:

Section I. The Zoning Map of unincorporated Richland County is hereby amended to change the real property described as TMS # R17116-01-01 from Residential Single-Family Medium Density District (RS-MD) to Residential Multi-Family Medium Density District (RM-MD).

Section II. Severability. If any section, subsection, or clause of this Ordinance shall be deemed to be unconstitutional, or otherwise invalid, the validity of the remaining sections, subsections, and clauses shall not be affected thereby.

Section III. Conflicting Ordinances Repealed. All ordinances or parts of ordinances in conflict with the provisions of this ordinance are hereby repealed.

Section IV. Effective Date. This ordinance shall be effective from and after _____, 2022.

RICHLAND COUNTY COUNCIL

By: _____
Overture Walker, Chair

Attest this _____ day of
_____, 2022

Anette A. Kirylo
Clerk of Council

RICHLAND COUNTY ATTORNEY'S OFFICE

Approved As To LEGAL Form Only.
No Opinion Rendered As To Content.

Public Hearing: October 25, 2022
First Reading: October 25, 2022
Second Reading: November 1, 2022
Third Reading: November 15, 2022

Richland County Council Request for Action

Subject:

22-016MA
John Stephenson
M-1 to RS-LD (138.5 Acres)
B/S Longwood Road
TMS # R18900-02-01

Notes:

First Reading: October 25, 2022
Second Reading:
Third Reading:
Public Hearing: October 25, 2022

STATE OF SOUTH CAROLINA
COUNTY COUNCIL OF RICHLAND COUNTY
ORDINANCE NO. ____-22HR

AN ORDINANCE OF THE COUNTY COUNCIL OF RICHLAND COUNTY, SOUTH CAROLINA, AMENDING THE ZONING MAP OF UNINCORPORATED RICHLAND COUNTY, SOUTH CAROLINA, TO CHANGE THE ZONING DESIGNATION FOR THE REAL PROPERTY DESCRIBED AS TMS # R18900-02-01 FROM LIGHT INDUSTRIAL (M-1) TO RESIDENTIAL SINGLE-FAMILY LOW DENSITY DISTRICT (RS-LD); AND PROVIDING FOR SEVERABILITY AND AN EFFECTIVE DATE.

Pursuant to the authority granted by the Constitution of the State of South Carolina and the General Assembly of the State of South Carolina, BE IT ENACTED BY RICHLAND COUNTY COUNCIL:

Section I. The Zoning Map of unincorporated Richland County is hereby amended to change the real property described as TMS # R18900-02-01 from Light Industrial (M-1) to Residential Single-Family Low Density District (RS-LD).

Section II. Severability. If any section, subsection, or clause of this Ordinance shall be deemed to be unconstitutional, or otherwise invalid, the validity of the remaining sections, subsections, and clauses shall not be affected thereby.

Section III. Conflicting Ordinances Repealed. All ordinances or parts of ordinances in conflict with the provisions of this ordinance are hereby repealed.

Section IV. Effective Date. This ordinance shall be effective from and after _____, 2022.

RICHLAND COUNTY COUNCIL

By: _____
Overture Walker, Chair

Attest this _____ day of
_____, 2022

Anette A. Kirylo
Clerk of Council

RICHLAND COUNTY ATTORNEY'S OFFICE

Approved As To LEGAL Form Only.
No Opinion Rendered As To Content.

Public Hearing: October 25, 2022
First Reading: October 25, 2022
Second Reading: November 1, 2022
Third Reading: November 15, 2022

Richland County Council Request for Action

Subject:

22-029MA
Douglas Putlock
NC to RS-MD (3 Acres)
1012 Bickly Road
TMS # R02415-02-01

Notes:

First Reading: October 25, 2022
Second Reading:
Third Reading:
Public Hearing: October 25, 2022

STATE OF SOUTH CAROLINA
COUNTY COUNCIL OF RICHLAND COUNTY
ORDINANCE NO. ____-22HR

AN ORDINANCE OF THE COUNTY COUNCIL OF RICHLAND COUNTY, SOUTH CAROLINA, AMENDING THE ZONING MAP OF UNINCORPORATED RICHLAND COUNTY, SOUTH CAROLINA, TO CHANGE THE ZONING DESIGNATION FOR THE REAL PROPERTY DESCRIBED AS TMS # R02415-02-01 FROM NEIGHBORHOOD COMMERCIAL DISTRICT (NC) TO RESIDENTIAL SINGLE-FAMILY MEDIUM DENSITY DISTRICT (RS-MD); AND PROVIDING FOR SEVERABILITY AND AN EFFECTIVE DATE.

Pursuant to the authority granted by the Constitution of the State of South Carolina and the General Assembly of the State of South Carolina, BE IT ENACTED BY RICHLAND COUNTY COUNCIL:

Section I. The Zoning Map of unincorporated Richland County is hereby amended to change the real property described as TMS # R02415-02-01 from Neighborhood Commercial District (NC) to Residential Single-Family Medium Density District (RS-MD).

Section II. Severability. If any section, subsection, or clause of this Ordinance shall be deemed to be unconstitutional, or otherwise invalid, the validity of the remaining sections, subsections, and clauses shall not be affected thereby.

Section III. Conflicting Ordinances Repealed. All ordinances or parts of ordinances in conflict with the provisions of this ordinance are hereby repealed.

Section IV. Effective Date. This ordinance shall be effective from and after _____, 2022.

RICHLAND COUNTY COUNCIL

By: _____
Overture Walker, Chair

Attest this _____ day of
_____, 2022

Anette A. Kirylo
Clerk of Council

RICHLAND COUNTY ATTORNEY'S OFFICE

Approved As To LEGAL Form Only.
No Opinion Rendered As To Content.

Public Hearing: October 25, 2022
First Reading: October 25, 2022
Second Reading: November 1, 2022
Third Reading: November 15, 2022

Richland County Council Request for Action

Subject:

22-032MA
Ervin Capers
HI to RU (4.86 Acres)
203 & 217 Gatehill Road & E/S McCords Ferry Rd.
TMS # R38800-02-09, R38900-03-06 and R38900-03-07

Notes:

First Reading: October 25, 2022
Second Reading:
Third Reading:
Public Hearing: October 25, 2022

STATE OF SOUTH CAROLINA
COUNTY COUNCIL OF RICHLAND COUNTY
ORDINANCE NO. ____-22HR

AN ORDINANCE OF THE COUNTY COUNCIL OF RICHLAND COUNTY, SOUTH CAROLINA, AMENDING THE ZONING MAP OF UNINCORPORATED RICHLAND COUNTY, SOUTH CAROLINA, TO CHANGE THE ZONING DESIGNATION FOR THE REAL PROPERTIES DESCRIBED AS TMS # R38800-02-09, R38900-03-06, AND R38900-03-07 FROM HEAVY INDUSTRIAL DISTRICT (HI) TO RURAL DISTRICT (RU); AND PROVIDING FOR SEVERABILITY AND AN EFFECTIVE DATE.

Pursuant to the authority granted by the Constitution of the State of South Carolina and the General Assembly of the State of South Carolina, BE IT ENACTED BY RICHLAND COUNTY COUNCIL:

Section I. The Zoning Map of unincorporated Richland County is hereby amended to change the real properties described as TMS # R38800-02-09, R38900-03-06, and R38900-03-07 from Heavy Industrial District (HI) to Rural District (RU).

Section II. Severability. If any section, subsection, or clause of this Ordinance shall be deemed to be unconstitutional, or otherwise invalid, the validity of the remaining sections, subsections, and clauses shall not be affected thereby.

Section III. Conflicting Ordinances Repealed. All ordinances or parts of ordinances in conflict with the provisions of this ordinance are hereby repealed.

Section IV. Effective Date. This ordinance shall be effective from and after _____, 2022.

RICHLAND COUNTY COUNCIL

By: _____
Overture Walker, Chair

Attest this _____ day of
_____, 2022

Anette A. Kirylo
Clerk of Council

RICHLAND COUNTY ATTORNEY'S OFFICE

Approved As To LEGAL Form Only.
No Opinion Rendered As To Content.

Public Hearing: October 25, 2022
First Reading: October 25, 2022
Second Reading: November 1, 2022
Third Reading: November 15, 2022

Richland County Council Request for Action

Subject:

Community Planning & Development - Building Inspections - South Carolina Building Codes Council Mandated 2021 Code Cycle

Notes:

October 25, 2022 – The Development & Services Committee recommended Council adopt the 2021 Building Codes, appendices, and modifications mandated by the South Carolina Building Codes Council as the standard for residential and commercial construction. In addition, to adopt the 2021 International Property Maintenance Code. This is a permissive code, and not mandated.

**RICHLAND COUNTY
ADMINISTRATION**

2020 Hampton Street, Suite 4069
Columbia, SC 29204
803-576-2050



Agenda Briefing

Prepared by:	Mike Zaprzalka	Title:	Building Official
Department:	Community Planning & Development	Division:	Building Inspections
Date Prepared:	August 1, 2022	Meeting Date:	October 25, 2022
Legal Review	Patrick Wright via email	Date:	September 27, 2022
Budget Review	Abhijit Deshpande via email	Date:	September 29, 2022
Finance Review	Stacey Hamm via email	Date:	September 28, 2022
Approved for consideration:	Assistant County Administrator	Aric A Jensen, AICP	
Meeting/Committee	Development & Services		
Subject	South Carolina Building Codes Council Mandated 2021 Code Cycle		

RECOMMENDED/REQUESTED ACTION:

Staff recommends that County Council adopt the 2021 Building Codes, appendices, and modifications mandated by South Carolina Building Codes Council as the standard for all residential and commercial construction.

Staff recommends that County Council adopt the 2021 International Property Maintenance Code. This is a permissive code, and not mandated. This is the reference and operational code of our County Ordinance Chapter 6, Article X, Property Maintenance, Section 6-182.

Request for Council Reconsideration: Yes

FIDUCIARY:

Are funds allocated in the department’s current fiscal year budget?	<input checked="" type="checkbox"/>	Yes	<input type="checkbox"/>	No
If not, is a budget amendment necessary?	<input type="checkbox"/>	Yes	<input type="checkbox"/>	No

ADDITIONAL FISCAL/BUDGETARY MATTERS TO CONSIDER:

Not applicable

Applicable department/grant key and object codes:

OFFICE OF PROCUREMENT & CONTRACTING FEEDBACK:

Not applicable

COUNTY ATTORNEY’S OFFICE FEEDBACK/POSSIBLE AREA(S) OF LEGAL EXPOSURE:

There are no legal concerns regarding this matter.

REGULATORY COMPLIANCE:

S.C. Code Ann. §6-9-50 (1976, as amended)

MOTION OF ORIGIN:

There is no associated Council motion of origin

Council Member	
Meeting	
Date	

STRATEGIC & GENERATIVE DISCUSSION:

On October 6, 2021, the South Carolina Building Codes Council approved and adopted codes and appendices, modifications and the latest editions of the mandatory codes referenced in S.C. Code Ann. §6-9-50 (1976, as amended) to be enforced by all municipalities and counties in South Carolina. The latest edition of ICC/ANSI A117.1, Accessible and Useable Buildings and Facilities, is adopted by the Accessibility Act, S.C. Code Ann. § 10-5-210 et seq. The Council established the implementation date for local jurisdictions as January 1, 2023.

The adopted modifications and the mandatory codes per South Carolina Codes Council are as follows:

- 2021 South Carolina Building Code or the 2021 International Building Code with SC modifications
- 2021 South Carolina Residential Code or the 2021 International Residential Code with SC modifications
- 2021 South Carolina Fire Code or the 2021 International Fire Code with SC modifications
- 2021 South Carolina Plumbing Code or the 2021 International Plumbing Code
- 2021 South Carolina Mechanical Code or the 2021 International Mechanical Code with SC modifications
- 2021 South Carolina Fuel Gas Code or the 2021 International Fuel Gas Code with SC modifications
- 2009 South Carolina Energy Conservation Code
- 2017 National Electrical Code (NFPA 70) with SC modifications
- 2017 ICC/ANSI A117.1 (Accessible and Useable Buildings and Facilities)

Appendices listed per South Carolina Codes Council are listed below:

- 2021 South Carolina Residential Code, appendix H (Patio Covers)
- 2021 South Carolina Residential Code, appendix J (Existing Building and Structures)
- 2021 South Carolina Residential Code, appendix Q (Tiny Homes)
- 2021 South Carolina Building Code, appendix H (Signs)

Permissive Code Adoption for County Ordinance / Article X / Sec.6-182/ Property Maintenance

- 2021 International Property Maintenance Code

ADDITIONAL COMMENTS FOR CONSIDERATION:

This mandated code change is being communicated to all builders by: bulletin postings, SC LLR website, Richland County Website, Permitting Specialist and Inspectors word of mouth.

All permits issued prior to 1 January 2023 will continue to work under the code cycle they were issued in. All permits issued on or after the implementation date will be required to operate under the new code cycle for code compliance.

ATTACHMENTS:

1. 2021 South Carolina Code Adoptions Bulletin
2. 2021 Modification and Appendices Index



2021 South Carolina Code Adoptions

On October 6, 2021, the South Carolina Building Codes Council adopted the latest editions of the mandatory codes and appendices with modifications, as referenced in S.C. Code Ann. §6-9-50 (1976, as amended), to be enforced by all municipalities and counties in South Carolina. The Council established the implementation date for local jurisdictions as **January 1, 2023**.

The adopted modifications and the mandatory codes are as follows:

2021 South Carolina Building Code or the 2021 International Building Code with SC modifications
2021 South Carolina Residential Code or the 2021 International Residential Code with SC modifications
2021 South Carolina Fire Code or the 2021 International Fire Code with SC modifications
2021 South Carolina Plumbing Code or the 2021 International Plumbing Code with SC modifications
2021 South Carolina Mechanical Code or the 2021 International Mechanical Code with SC modifications
2021 South Carolina Fuel Gas Code or the 2021 International Fuel Gas Code with SC modifications
2009 South Carolina Energy Conservation Code
2020 National Electrical Code (NFPA 70) with SC modifications

Print and PDF download versions of the 2021 South Carolina codes are available for pre-order from the [ICC website](#).

The International Codes are to be used in conjunction with the latest [code modifications](#) approved by the Council. Only the modifications approved and listed on the Council's website are valid for use in the State. Building code modifications that have not been approved by the Council are invalid and cannot be adopted, employed or enforced by municipalities and counties.

The latest edition of ICC/ANSI A117.1, Accessible and Useable Buildings and Facilities, is adopted by the [Accessibility Act](#), S.C. Code Ann. § 10-5-210 et seq., and is mandatory for use in all municipalities and counties within the State.

The Building [Energy Standard Act](#) is adopted by statute and mandatory for use in all jurisdictions within the state.

Additional information can be found on the South Carolina Building Codes Council's [website](#).



South Carolina Department of Labor, Licensing and Regulation
South Carolina Building Codes Council
 110 Centerview Dr • Columbia • SC • 29210
 P.O. Box 11329 • Columbia • SC • 29211-1329
 Phone: 803-896-4688 • contact.bcc@llr.sc.gov • Fax: 803-896-4814
 llr.sc.gov/bcc

2021 MODIFICATION INDEX

*Modification Index numbers below are hyperlinked to the referenced modifications. The LLR logo on each modification page links back to index.

MODIFICATION INDEX NUMBER	CODE SECTION	REQUESTING ASSOCIATION/ JURISDICTION	NEW/ CONTINUATION
2021 IBC			
IBC 2021-01	[A] 101.4.7 Existing Buildings	American Concrete Institute (ACI)	New
IBC 2021-02	202 Definitions	BOASC	Continuation
IBC 2021-04	303.4 Assembly Group A-3	BOASC	Continuation
IBC 2021-05	312.1 General "Primitive Camp Structure"	BOASC	Continuation
IBC 2021-07	706.1 General	BOASC	Continuation
IBC 2021-10	1010.2.14 Controlled egress doors in Groups I-1 and I-2 (also in IFC)	Midlands Fire Marshal's Association	New
IBC 2021-11	1016.2 Egress through intervening spaces	BOASC	Continuation
IBC 2021-14	1803.2 Investigations required	BOASC	Continuation
IBC 2021-16	1907.1 General	Structural Engineers	Continuation
IBC 2021-17	2303.2.2 Other means during manufacture	BOASC	Continuation
IBC 2021-18	Appendix H Signs	Structural Engineers	Continuation
2021 IRC			
IRC 2021-01	R202 Definitions - Accepted Eng. Practice	Coastal Code Enforcement Association of SC	Continuation
IRC 2021-02	R202 Definitions - Crawl Space	HBA of SC	New
IRC 2021-04	R301.2.1 Wind Design Criteria	HBA of SC	New
IRC 2021-05	R301.2.2.1 Determination of seismic design category	HBA of SC	New
IRC 2021-06	R302.1 Exterior Walls (Add Exception 6)	Coastal Code Enforcement Association of SC	Continuation
IRC 2021-07	R302.1 Exterior Walls (Add Exception 7)	BOASC	New
IRC 2021-09	R302.4.1 Through penetrations	BOASC	New
IRC 2021-10	R302.5.1 Opening protection	HBA of SC	Continuation
IRC 2021-11	R302.13 Fire Protection of floors	HBA of SC	Continuation
IRC 2021-12	R303.4 Mechanical ventilation	Coastal Code Enforcement Association of SC	Continuation
IRC 2021-13	Figure R307.1 Minimum Fixture Clearances	HBA of SC	Continuation
IRC 2021-15	R311.7.5.1 Risers	Structural Engineers Association of SC	Continuation
IRC 2021-16	R312.1.1 Where required	HBA of SC	Continuation
IRC 2021-17	R312.2 Window fall protection	HBA of SC	Continuation
IRC 2021-18	R313 Automatic Fire Sprinkler Systems	HBA of SC	Continuation
IRC 2021-22	R317.1.1 Field treatment	Structural Engineers Association of SC	Continuation
IRC 2021-23	R318.1 Subterranean termite control methods	HBA of SC	Continuation
IRC 2021-24	R318.4 Foam Plastic Protection	HBA of SC	Continuation
IRC 2021-25	R318.5 Termite Inspection Strip	HBA of SC	New
IRC 2021-28	R322.1 General	BOASC	Continuation
IRC 2021-29	R326.3 Story above grade plane	HBA of SC	New
IRC 2021-31	R404.1.9.2 Masonry Piers Supporting floor girders	HBA of SC & Structural Engineers Association of SC	Continuation

MODIFICATION INDEX NUMBER	CODE SECTION	REQUESTING ASSOCIATION/ JURISDICTION	NEW/ CONTINUATION
IRC 2021-32	R408.3 Unvented Crawl Space	Structural Engineers Association of SC	Continuation
IRC 2021-33	R408.3(2.2) Unvented crawl space	HBA of SC	New
IRC 2021-34	R408.4 Access	HBA of SC	Continuation
IRC 2021-35	R408.8 Under-floor vapor retarder	HBA of SC	New
IRC 2021-36	R502.11.4 Truss design drawings	HBA of SC	Continuation
IRC 2021-37	R506.2.3 Vapor retarder	Structural Engineers Association of SC	Continuation
IRC 2021-38	R606.7 Piers	Structural Engineers Association of SC	Continuation
IRC 2021-39	R802.10.1 Truss design drawings	HBA of SC	Continuation
IRC 2021-40	R905.2.8.5 Drip Edge	HBA of SC	Continuation
IRC 2021-41	Chapter 11 Energy Efficiency	HBA of SC	Continuation
IRC 2021-42	M1411.6 Insulation of refrigerant piping	HBA of SC	Continuation
IRC 2021-43	M1411.9 Locking access port caps	HBA of SC	Continuation
IRC 2021-44	M1502.3 Duct termination	HBA of SC	Continuation
IRC 2021-45	M1502.4.2 Duct Installation	HBA of SC	Continuation
IRC 2021-46	M1502.4.6 Duct length	HBA of SC	Continuation
IRC 2021-47	M1503.6 Makeup air	HBA of SC	Continuation
IRC 2021-48	M1504.3 Exhaust Openings	HBA of SC	Continuation
IRC 2021-49	M1601.4.1 Joints, Seams and Connections	HBA of SC	Continuation
IRC 2021-50	G2418.2 Design and installation	HBA of SC	Continuation
IRC 2021-51	P2503.6 Shower liner test	HBA of SC	Continuation
IRC 2021-52	P2503.6 Shower liner test	HBA of SC	New (Adds to continuation)
IRC 2021-53	P2603.2.1 Protection against physical damage	HBA of SC	New
IRC 2021-54	P2603.5 Freezing	HBA of SC	Continuation
IRC 2021-55	P2603.5 Freezing	HBA of SC	New (Adds to continuation)
IRC 2021-56	P2705.1 (3) General	HBA of SC	New
IRC 2021-57	P2708.4 Shower control valves	HBA of SC	New
IRC 2021-58	P2713.3 Bathtub and whirlpool bathtub valves	HBA of SC	New
IRC 2021-60	P2903.10 Hose bibb	HBA of SC	Continuation
IRC 2021-62	P2904.2.4.2.1 Additional requirements for pendant sprinklers	SC Master Plumbers Association	New
IRC 2021-66	E3606.5 Surge Protection	HBA of SC	New
IRC 2021-67	E3802.4 In unfinished basements	HBA of SC	Continuation
IRC 2021-69	E3901.4.2 (1) – Island and peninsular countertops and work spaces	HBA of SC	New
IRC 2021-70	E3902 Ground-Fault & Arc-Fault Circuit-Interrupter Protection	HBA of SC	New
IRC 2021-71	E3902.5 Basement Receptacles	HBA of SC	New
IRC 2021-73	E3902.17 Arc-Fault Circuit Interrupter Protection	HBA of SC	Continuation
IRC 2021-75	E4002.14 Tamper-resistant receptacles	HBA of SC	New
IRC 2021-76	Chapter 44 Referenced Standards	AHRI	New
IRC 2021-77	Appendix AH Patio Covers	Structural Engineers Association of SC	Continuation
IRC 2021-78	Appendix AJ Existing Buildings and Structures	Structural Engineers Association of SC	Continuation
IRC 2021-79	Appendix AQ Tiny Houses	BOASC	Continuation

MODIFICATION INDEX NUMBER	CODE SECTION	REQUESTING ASSOCIATION/ JURISDICTION	NEW/ CONTINUATION
2021 IFC			
IFC 2021-02	202 General definitions - Primitive camp structure	BOASC	Continuation
IFC 2021-03	202 General definitions - A-3 occupancies	BOASC	Continuation
IFC 2021-04	202 General definitions - Recreational Fire	SC Fire Marshal's Association	Continuation
IFC 2021-05	315.3.3 Equipment rooms	Midlands Fire Marshal's Association	New
IFC 2021-07	319.11 Clearance requirements (New Section)	Midlands Fire Marshal's Association	New
IFC 2021-08	503.1.2 Additional Access	HBA of SC	New
IFC 2021-09	503.1.2.1 One- or two-family dwelling residential developments having less than 50 units (New section)	HBA of SC	New
IFC 2021-10	503.2.1 Dimensions	HBA of SC	Continuation
IFC 2021-11	507.1 Required water supply	Charleston Fire Department	Continuation
IFC 2021-12	507.5.1 Where Required	Charleston Fire Department	Continuation
IFC 2021-13	507.5.1.1 Hydrant for standpipe systems	Midlands Fire Marshal's Association	New
IFC 2021-14	507.5.4 Obstruction	Midlands Fire Marshal's Association	New
IFC 2021-16	607.1 General	Midlands Fire Marshal's Association	New
IFC 2021-19	901.6.3 Records	Charleston Fire Department	Continuation
IFC 2021-22	907.6.5 Access	Midlands Fire Marshal's Association	New
IFC 2021-24	1010.2.14 Controlled egress doors in Groups I-1 and I-2 (Also in IBC)	Midlands Fire Marshal's Association	New
IFC 2021-25	1016.2 Egress through intervening spaces	Charleston Fire Department	Continuation
IFC 2021-31	2303.2.2 Testing (New section)	Midlands Fire Marshal's Association	New
IFC 2021-33	2305.5 Fire extinguishers	Midlands Fire Marshal's Association	New
IFC 2021-34	2307.4 Location of dispensing operations and equipment	SCPGA	Continuation
IFC 2021-35	2307.7 Public fueling of motor vehicles	SCPGA	Continuation
IFC 2021-38	6101.1 Scope	SC Fire Marshal's Association	Continuation
IFC 2021-41	6106.1 Attendants	SC Fire Marshal's Association	Continuation
IFC 2021-42	6107.4 Protecting containers from vehicles	SC Fire Marshal's Association	Continuation
IFC 2021-43	6109.13 Protection of containers	SC Fire Marshal's Association	Continuation
IFC 2021-44	6110.1 Removed from service	SC Fire Marshal's Association	Continuation
IFC 2021-45	6111.2.1 Near residential, educational and institutional occupancies and other high-risk areas	SC Fire Marshal's Association	Continuation
2021 IPC			
IPC 2021-01	202 General Definitions - Drinking Fountain	Carolinas AGC	New
IPC 2021-02	202 General Definitions - Bottle Filling Station	Carolinas AGC	New
IPC 2021-03	202 General Definitions - Water Cooler	Carolinas AGC	New
IPC 2021-04	202 General Definitions - Water Dispenser	Carolinas AGC	New
IPC 2021-05	Table 403.1 Minimum number of required plumbing fixtures	Carolinas AGC	New
IPC 2021-06	410.4 Substitution	Carolinas AGC	New
2021 IMC			
IMC 2021-01	504.9.2 Duct Installation	BOASC	Continuation
IMC 2021-02	Table 1103.1 Refrigerant Classification Amount and OEL	AHRI	New

MODIFICATION INDEX NUMBER	CODE SECTION	REQUESTING ASSOCIATION/ JURISDICTION	NEW/ CONTINUATION
IMC 2021-03	1104.3 System Application Requirements	AHRI	New
IMC 2021-04	Chapter 15 Referenced Standards	AHRI	New
2021 IFGC			
IFGC 2021-01	401.9 Identification	SCPGA	Continuation
IFGC 2021-02	401.10 Third-party testing and certification	SCPGA	Continuation
IFGC 2021-03	412.4 Listed equipment	SCPGA	Continuation
IFGC 2021-04	412.6 Location	SCPGA	Continuation
IFGC 2021-05	412.8.3 Vehicle impact protection	SCPGA	Continuation
IFGC 2021-06	412.10 Private fueling of motor vehicles	SCPGA	Continuation
IFGC 2021-07	505.1.1 Commercial cooking appliances vented by exhaust hoods	Piedmont Natural gas	Continuation
2020 NEC			
NEC 2020-03	210.8(A)(5) Basements	HBA of SC	New
NEC 2020-04	210.8(F) Outdoor Outlets	HBA of SC	New
NEC 2020-05	210.12 Arc-Fault Circuit-Interpreter Protection	HBA of SC	New
NEC 2020-06	230.67 Surge Protection	HBA of SC	New



South Carolina Department of Labor, Licensing and Regulation
South Carolina Building Codes Council
2021 Modification Index

Applicable Code: 2021 International Building Code

Modification Index Number: IBC 2021-01

Code Section: [A] 101.4.7 Existing Buildings

Modification:

[A] 101.4.7 Existing buildings. The provisions of the South Carolina Existing Building Code shall apply to matters governing the repair, alternation, change of occupancy, addition to and relocation of existing buildings.

101.4.7.1 Structural Concrete. In addition, assessment, repairs, and restoration of structural concrete in accordance with ACI 562 shall be permitted.

Exception:
ACI 562 shall not be used for the evaluation or design of repairs or rehabilitation of elements of seismic force-resisting system that result in strength, stiffness, or ductility of those elements different from the pre-damage condition.

Add new referenced standard to Chapter 16 as follows:

ACI American Concrete Institute
38800 Country Club Drive
Farmington Hills, MI 48331
Standard reference number Title Referenced in code section number
562-19 Code Requirements for Assessment, Repair, and Rehabilitation of Existing Concrete Structures
101.4.7.1

Proponent: American Concrete Institute (ACI)

Previous Code Cycles	Previous Modification Index Number	Previous Code Section
n/a		



South Carolina Department of Labor, Licensing and Regulation
South Carolina Building Codes Council
2021 Modification Index

Applicable Code: 2021 International Building Code

Modification Index Number: IBC 2021-02

Code Section: 202 Definitions

Modification:

VAPOR RETARDER, GROUND CONTACT. Ground contact vapor retarder class shall be defined using the requirements of ASTM E1745, Class A, B, or C-Standard specification for water vapor retarders used in contact with soil or granular fill under concrete slabs.

PRIMITIVE CAMP STRUCTURE. Shall include any structure permanent or temporary in nature, used for outdoor camping (transient), open on at least one side with no fully enclosed habitable spaces, less than 400 square feet under roof, and not classified as a residential occupancy due to lack of electrical, plumbing, mechanical and sprinkler systems.

Proponent: BOASC

Previous Code Cycles	Previous Modification Index Number	Previous Code Section
IBC 2018	IBC 2018 01	202



South Carolina Department of Labor, Licensing and Regulation
South Carolina Building Codes Council
2021 Modification Index

Applicable Code: 2021 International Building Code

Modification Index Number: IBC 2021-04

Code Section: 303.4 Assembly Group A-3

Modification:

303.4 Assembly Group A-3. Group A-3 occupancy includes assembly uses intended for worship, recreation or amusement and other assembly uses not classified elsewhere in Group A including, but not limited to:

- Amusement arcades
- Art galleries
- Bowling alleys
- Community halls
- Courtrooms
- Dance halls (not including food or drink consumption)
- Exhibition halls
- Funeral parlors
- Greenhouses* for the conservation and exhibition of plants that provide public access
- Gymnasiums (without spectator seating)
- Indoor *swimming pools* (without spectator seating)
- Indoor tennis courts (without spectator seating)
- Lecture halls
- Libraries
- Museums
- Places of religious worship*
- Pool and billiard parlors
- Structures, without a commercial kitchen, used in agritourism activity as defined by S.C. Code Ann. 46-53-10(1)
- Waiting areas in transportation terminals

Proponent: BOASC

Previous Code Cycles	Previous Modification Index Number	Previous Code Section
IBC 2018	IBC 2018 02	303.4



South Carolina Department of Labor, Licensing and Regulation
South Carolina Building Codes Council
2021 Modification Index

Applicable Code: 2021 International Building Code

Modification Index Number: IBC 2021-05

Code Section: 312.1 General.

Modification:

SECTION 312

UTILITY AND MISCELLANEOUS GROUP U

312.1 General. Buildings and structures of an accessory character and miscellaneous structures not classified in any specific occupancy shall be constructed, equipped and maintained to conform to the requirements of this code commensurate with the fire and life hazard incidental to their occupancy. Group U shall include, but not be limited to, the following:

Agricultural buildings

Aircraft hangars, accessory to a one- or two-family residence (see Section 412.4)

Barns

Carports

Communication equipment structures with a *gross floor area* of less than 1,500 square feet (139 m²)

Fences more than 7 feet (2134 mm) in height

Grain silos, accessory to a residential occupancy

Livestock shelters

Primitive Camp Structures

Private garages

Retaining walls

Sheds

Stables

Proponent: BOASC

Previous Code Cycles	Previous Modification Index Number	Previous Code Section
IBC 2018	IBC 2018 03	312.1



South Carolina Department of Labor, Licensing and Regulation
South Carolina Building Codes Council
2021 Modification Index

Applicable Code: 2021 International Building Code

Modification Index Number: IBC 2021-07

Code Section: 706.1 General

Modification:

706.1 General. *Fire walls* shall be constructed in accordance with Sections 706.2 through 706.11. Each portion of a building separated by one or more firewalls may be considered a separate building. The extent and location of such *fire walls* shall provide a complete separation. Where a *fire wall* separates occupancies that are required to be separated by a *fire barrier wall*, the most restrictive requirements of each separation shall apply.

Proponent: BOASC

Previous Code Cycles	Previous Modification Index Number	Previous Code Section
IBC 2018	IBC 2018 05	706.1



South Carolina Department of Labor, Licensing and Regulation
South Carolina Building Codes Council
2021 Modification Index

Applicable Code: 2021 International Building Code

Modification Index Number: IBC 2021-10

Code Section: 1010.2.14 Controlled egress doors in Group I-1 and I-2

Modification:

1010.2.14 Controlled egress doors in Groups I-1, I-2, and I-4 (Adult Day Care Occupancy only).

Electric locking systems, including electro-mechanical locking systems and electromagnetic locking systems, shall be permitted to be locked in the means of egress in Group I-1, I-2, and I-4 (Adult Day Care occupancy only) occupancies where the clinical needs of persons receiving care require their containment. Controlled egress doors shall be permitted in such occupancies where the building is equipped throughout with an automatic sprinkler system in accordance with Section 903.3.1.1 or an approved automatic smoke detection system installed in accordance with Section 907, provided that the doors are installed and operate in accordance with all of the following:

1. The door locks shall unlock on actuation of the automatic sprinkler system or automatic smoke detection system.
2. The door locks shall unlock on loss of power controlling the lock or lock mechanism.
3. The door locking system shall be installed to have the capability of being unlocked by a switch located at the fire command center, a nursing station or other approved location. The switch shall directly break power to the lock.
4. A building occupant shall not be required to pass through more than one door equipped with a controlled egress locking system before entering an exit.
5. The procedures for unlocking the doors shall be described and approved as part of the emergency planning and preparedness required by Chapter 4 of the International Fire Code.
6. All clinical staff shall have the keys, codes or other means necessary to operate the locking systems.
7. Emergency lighting shall be provided at the door.
8. The door locking system units shall be listed in accordance with UL 294.

Exceptions:

1. Items 1 through 4 shall not apply to doors to areas occupied by persons who, because of clinical needs, require restraint or containment as part of the function of a psychiatric or cognitive treatment area.
2. Items 1 through 4 shall not apply to doors to areas where a listed egress control system is utilized to reduce the risk of child abduction from nursery and obstetric areas of a Group I-2 hospital.

Proponent: Midlands Fire Marshal's Association

Previous Code Cycles	Previous Modification Index Number	Previous Code Section
n/a		



South Carolina Department of Labor, Licensing and Regulation
South Carolina Building Codes Council
2021 Modification Index

Applicable Code: 2021 International Building Code

Modification Index Number: IBC 2021-11

Code Section: 1016.2 Egress through intervening spaces

Modification:

1016.2 Egress through intervening spaces. Egress through intervening spaces shall comply with this section.

1. Exit access through an enclosed elevator lobby is permitted. Where access to two or more exits or exit access doorways is required in Section 1006.2.1, access to not less than one of the required exits shall be provided without travel through the enclosed elevator lobbies required by Section 3006 of the South Carolina Building Code. Where the path of exit access travel passes through an enclosed elevator lobby, the level of protection required for the enclosed elevator lobby is not required to be extended to the exit unless direct access to an exit is required by other sections of this code.
2. Egress from a room or space shall not pass through adjoining or intervening rooms or areas, except where such adjoining rooms or areas and the area served are accessory to one or the other, are not a Group H occupancy and provide a discernible path of egress travel to an exit.

Exception: Means of egress are not prohibited through adjoining or intervening rooms or spaces in a Group H, S or F occupancy where the adjoining or intervening rooms or spaces are the same or a lesser hazard occupancy group.
3. An exit access shall not pass through a room that can be locked to prevent egress.
4. Means of egress from dwelling units or sleeping areas shall not lead through other sleeping areas, toilet rooms or bathrooms.

Exception: Dwelling units or sleeping areas in R-1 and R-2 occupancies shall be permitted to egress through other sleeping areas serving adjoining rooms that are part of the same dwelling unit or guest room.
5. Egress shall not pass through kitchens, storage rooms, closets or spaces used for similar purposes.

Exceptions:
 1. Means of egress are not prohibited through a kitchen area serving adjoining rooms constituting part of the same dwelling unit or sleeping unit.
 2. Means of egress are not prohibited through stockrooms in Group M occupancies where all of the following are met:
 - 2.1. The stock is of the same hazard classification as that found in the main retail area.
 - 2.2. Not more than 50 percent of the exit access is through the stockroom.
 - 2.3. The stockroom is not subject to locking from the egress side.
 - 2.4. There is a demarcated, minimum 44-inch-wide (1118 mm) aisle defined by ~~full- or partial-height fixed walls~~ a wall not less than 42 inches high or similar construction that will maintain the required width and lead directly from the retail area to the exit without obstructions.

Proponent: BOASC

Previous Code Cycles	Previous Modification Index Number	Previous Code Section
IBC 2018	IBC 2018 10	1016.2



South Carolina Department of Labor, Licensing and Regulation
South Carolina Building Codes Council
2021 Modification Index

Applicable Code: 2021 International Building Code

Modification Index Number: IBC 2021-14

Code Section: 1803.2 Investigations required

Modification:

1803.2 Investigations required. Geotechnical investigations shall be conducted in accordance with Sections 1803.3 through 1803.5.

Exception:

1. The *building official* shall be permitted to waive the requirement for a geotechnical investigation where satisfactory data from adjacent areas is available that demonstrates an investigation is not necessary for any of the conditions in Sections 1803.5.1 through 1803.5.6 and Sections 1803.5.10 and 1803.5.11.

2. For single story buildings not more than 5,000 sq ft and not more than 30ft in height, a site specification investigation report is not required if the seismic design category is determined by the design professional in accordance with Chapter 20 of ASCE 7.

Proponent: BOASC

Previous Code Cycles	Previous Modification Index Number	Previous Code Section
IBC 2018	IBC 2018 11	1803.2



South Carolina Department of Labor, Licensing and Regulation
South Carolina Building Codes Council
2021 Modification Index

Applicable Code: 2021 International Building Code

Modification Index Number: IBC 2021-16

Code Section: 1907.1 General

Modification:

SECTION 1907

MINIMUM SLAB PROVISIONS

1907.1 General. The thickness of concrete floor slabs supported directly on the ground shall be not less than 3½ inches (89 mm). A 6-mil (0.006 inch; 0.15 mm) 10-mil (0.010 inch) polyethylene ground contact vapor retarder with joints lapped not less than 6 inches (152 mm) shall be placed between the base course or subgrade and the concrete floor slab, or other *approved* equivalent methods or materials shall be used to retard vapor transmission through the floor slab.

Exception: A vapor retarder is not required:

1. For detached structures accessory to occupancies in Group R-3, such as garages, utility buildings or other unheated facilities.
2. For unheated storage rooms having an area of less than 70 square feet (6.5 m²) and carports attached to occupancies in Group R-3.
3. For buildings of other occupancies where migration of moisture through the slab from below will not be detrimental to the intended occupancy of the building.
4. For driveways, walks, patios and other flatwork that will not be enclosed at a later date.
5. Where *approved* based on local site conditions.

Proponent: Structural Engineers' Association of SC

Previous Code Cycles	Previous Modification Index Number	Previous Code Section
IBC 2018	IBC 2018 12	1907.1



South Carolina Department of Labor, Licensing and Regulation
South Carolina Building Codes Council
2021 Modification Index

Applicable Code: 2021 International Building Code

Modification Index Number: IBC 2021-17

Code Section: 2303.2.2 Others means during manufacture

Modification:

2303.2.2 Other means during manufacture. For wood products impregnated with chemicals by other means during manufacture, the treatment shall be an integral part of the manufacturing process of the wood product. The treatment shall provide permanent protection to all surfaces of the wood product. ~~The use of paints, coating, stains or other surface treatments is not an approved method of protection as required in this section.~~

Proponent: BOASC

Previous Code Cycles	Previous Modification Index Number	Previous Code Section
IBC 2018	IBC 2018 13	2303.2.2



South Carolina Department of Labor, Licensing and Regulation
South Carolina Building Codes Council
2021 Modification Index

Applicable Code: 2021 International Building Code

Modification Index Number: IBC 2021-18

Code Section: Appendix H Signs

Modification:

Appendix H was adopted for use statewide.

Appendix H Signs

Appendix H gathers in one place the various code standards that regulate the construction and protection of outdoor signs. Whenever possible, this appendix provides standards in performance language, thus allowing the widest possible application.

Proponent: Structural Engineers Association of South Carolina

Previous Code Cycles	Previous Modification Index Number	Previous Code Section
IBC 2018	IBC 2018 14	Appendix H
IBC 2015	IBC 2015 07	Appendix H
IBC 2012	IBC 2012 05	Appendix H



South Carolina Department of Labor, Licensing and Regulation
South Carolina Building Codes Council
2021 Modification Index

Applicable Code: 2021 International Residential Code

Modification Index Number: IRC 2021-01

Code Section: R202 Definitions

Modification:

ACCEPTED ENGINEERING PRACTICE - The performance design of structures and/or structural elements that vary from prescriptive design methods of this code. Such design shall be made with accepted design standards by a South Carolina licensed Architect or Engineer as permitted by existing state law.

Proponent: Coastal Code Enforcement Association of SC

Previous Code Cycles	Previous Modification Index Number	Previous Code Section
IRC 2018	IRC 2018 01	R202 Definitions
IRC 2015	IRC 2015 01	R202 Definitions
IRC 2012	IRC 2012 01	R202 Definitions



South Carolina Department of Labor, Licensing and Regulation
South Carolina Building Codes Council
2021 Modification Index

Applicable Code: 2021 International Residential Code

Modification Index Number: IRC 2021-02

Code Section: R202 Definitions

Modification:

[RB] CRAWL SPACE. An underfloor space that is not a *basement*. Spaces under decks and porches that do not contain mechanical equipment are not to be considered crawlspaces.

Proponent: Home Builders Association of South Carolina

Previous Code Cycles	Previous Modification Index Number	Previous Code Section
N/A		



South Carolina Department of Labor, Licensing and Regulation
South Carolina Building Codes Council
2021 Modification Index

Applicable Code: 2021 International Residential Code

Modification Index Number: IRC 2021-04

Code Section: R301.2.1 Wind design criteria

Modification:

R301.2.1 Wind design criteria. Buildings and portions thereof shall be constructed in accordance with the wind provisions of this code using the ultimate design wind speed in Table R301.2 as determined from Figure R301.2(2) the previously published maps by the S.C. Building Codes Council. The local building official may delineate the wind design category within their jurisdiction, as long as, it does not surpass those provided on the Applied Technology Council (ATC) website. The structural provisions of this code for wind loads are not permitted where wind design is required as specified in Section R301.2.1.1. Where different construction methods and structural materials are used for various portions of a building, the applicable requirements of this section for each portion shall apply. Where not otherwise specified, the wind loads listed in Table R301.2.1(1) adjusted for height and exposure using Table R301.2.1(2) shall be used to determine design load performance requirements for wall coverings, curtain walls, roof coverings, exterior windows, skylights, garage doors and exterior doors. Asphalt shingles shall be designed for wind speeds in accordance with Section R905.2.4. *Metal roof shingles* shall be designed for wind speeds in accordance with Section R905.4.4. A continuous load path shall be provided to transmit the applicable uplift forces in Section R802.11 from the *roof assembly* to the foundation. Where ultimate design wind speeds in Figure R301.2(2) are less than the lowest wind speed indicated in the prescriptive provisions of this code, the lowest wind speed indicated in the prescriptive provisions of this code shall be used.

Proponent: Home Builders Association of South Carolina

Previous Code Cycles	Previous Modification Index Number	Previous Code Section
N/A		



South Carolina Department of Labor, Licensing and Regulation
South Carolina Building Codes Council
2021 Modification Index

Applicable Code: 2021 International Residential Code

Modification Index Number: IRC 2021-05

Code Section: R301.2.2.1 Determination of seismic design category

Modification:

R301.2.2.1 Determination of seismic design category. Buildings shall be assigned a seismic design category in accordance with the previously published maps by the S.C. Building Codes Council. ~~Figures R301.2.2.1(1) through R301.2.2.1(6).~~ The local building official may delineate the seismic design category within the jurisdiction, as long as, it does not surpass those provided on the Applied Technology Council (ATC) website.

Proponent: Home Builders Association of South Carolina

Previous Code Cycles	Previous Modification Index Number	Previous Code Section
N/A		



South Carolina Department of Labor, Licensing and Regulation
South Carolina Building Codes Council
2021 Modification Index

Applicable Code: 2021 International Residential Code

Modification Index Number: IRC 2021-06

Code Section: R302.1 Exterior walls

Modification:

R302.1 Exterior walls. Construction, projections, openings and penetrations of exterior walls of *dwelling*s and accessory buildings shall comply with Table R302.1(1); or *dwelling*s equipped throughout with an *automatic sprinkler system* installed in accordance with Section P2904 shall comply with Table R302.1(2).

Exceptions:

1. Walls, projections, openings or penetrations in walls perpendicular to the line used to determine the *fire separation distance*.
2. Walls of *individual dwelling units* and their *accessory structures* located on the same *lot*.
3. Detached tool sheds and storage sheds, playhouses and similar structures exempted from *permits* are not required to provide wall protection based on location on the *lot*. Projections beyond the exterior wall shall not extend over the *lot line*.
4. Detached garages accessory to a *dwelling* located within 2 feet (610 mm) of a *lot line* are permitted to have roof eave projections not exceeding 4 inches (102 mm).
5. Foundation vents installed in compliance with this code are permitted.
6. Fire separation distance.
 - a. The minimum fire separation distance for improvement constructed on a lot shown on: [i] a recorded bonded or final subdivision plat, or [ii] a sketch plan, site plan, plan of phased development or preliminary plat approved by the local governing authority which was recorded or approved prior to the implementation of IRC 2012 which shows or describes lesser setbacks than the fire separation distances provided in Table R302.1(1) shall be equal to the lesser setbacks, but in no event less than 3 feet.
 - b. The minimum fire separation distance for improvements constructed on a lot where the local governing authority has prior to the implementation of IRC 2012: [i] accepted exactions or issued conditions, [ii] granted a special exception, [iii] entered into a development agreement, [iv] approved a variance, [v] approved a planned development district, or [vi] otherwise approved a specific development plan which contemplated or provided for setbacks less than the fire separation distances provided in Table R302.1(1) shall be equal to the lesser setback, but in no event less than 3 feet.

Proponent: Coastal Code Enforcement Association of South Carolina

Previous Code Cycles	Previous Modification Index Number	Previous Code Section
IRC 2018	IRC 2018 04	R302.1
IRC 2015	IRC 2015 01	R302.1
IRC 2012	IRC 2012 02	R302.1



South Carolina Department of Labor, Licensing and Regulation
South Carolina Building Codes Council
2021 Modification Index

Applicable Code: 2021 International Residential Code

Modification Index Number: IRC 2021-07

Code Section: R302.1 Exterior walls

Modification:

R302.1 Exterior walls. Construction, projections, openings and penetrations of exterior walls of *dwelling*s and accessory buildings shall comply with Table R302.1(1); or *dwelling*s equipped throughout with an *automatic sprinkler system* installed in accordance with Section P2904 shall comply with Table R302.1(2).

Exceptions:

1. Walls, projections, openings or penetrations in walls perpendicular to the line used to determine the *fire separation distance*.
2. Walls of *individual dwelling units* and their *accessory structures* located on the same *lot*.
3. Detached tool sheds and storage sheds, playhouses and similar structures exempted from *permits* are not required to provide wall protection based on location on the *lot*. Projections beyond the exterior wall shall not extend over the *lot line*.
4. Detached garages accessory to a *dwelling* located within 2 feet (610 mm) of a *lot line* are permitted to have roof eave projections not exceeding 4 inches (102 mm).
5. Foundation vents installed in compliance with this code are permitted.
6. Fire separation distance.
 - a. The minimum fire separation distance for improvement constructed on a lot shown on: [i] a recorded bonded or final subdivision plat, or [ii] a sketch plan, site plan, plan of phased development or preliminary plat approved by the local governing authority which was recorded or approved prior to the implementation of IRC 2012 which shows or describes lesser setbacks than the fire separation distances provided in Table R302.1(1) shall be equal to the lesser setbacks, but in no event less than 3 feet.
 - b. The minimum fire separation distance for improvements constructed on a lot where the local governing authority has prior to the implementation of IRC 2012: [i] accepted exactions or issued conditions, [ii] granted a special exception, [iii] entered into a development agreement, [iv] approved a variance, [v] approved a planned development district, or [vi] otherwise approved a specific development plan which contemplated or provided for setbacks less than the fire separation distances provided in Table R302.1(1) shall be equal to the lesser setback, but in no event less than 3 feet.
7. Aesthetic roof and siding projections may extend beyond the common wall of a townhouse unit over an adjoining unit's property line as long as the construction of the projection does not damage the integrity of the fire rated assembly, the projection is completely supported by the common wall, the projection is protected by one hour construction or fire retardant-treated wood, and the projection is limited to 18-inches. These projections shall not contain any plumbing, electrical or mechanical installations. An easement may be required by the jurisdiction to ensure future access to this projection for repair and maintenance.

*Modification adds to modified language in IRC 2021-06.

Proponent: BOASC

Previous Code Cycles	Previous Modification Index Number	Previous Code Section
N/A		



South Carolina Department of Labor, Licensing and Regulation
South Carolina Building Codes Council
2021 Modification Index

Applicable Code: 2021 International Residential Code

Modification Index Number: IRC 2021-09

Code Section: R302.4.1 Through penetrations

Modification:

R302.4.1 Through penetrations. Through penetrations of fire-resistance-rated wall or floor assemblies shall comply with Section R302.4.1.1 or R302.4.1.2. No penetrations shall pass completely through the fire rated assembly separating townhouse units.

Exceptions:

1. Where the penetrating items are steel, ferrous or copper pipes, tubes or conduits, the annular space shall be protected as follows:
 - 1.1. In concrete or masonry wall or floor assemblies, concrete, grout or mortar shall be permitted where installed to the full thickness of the wall or floor assembly or the thickness required to maintain the fire-resistance rating, provided that both of the following are complied with:
 - 1.1.1. The nominal diameter of the penetrating item is not more than 6 inches (152 mm).
 - 1.1.2. The area of the opening through the wall does not exceed 144 square inches (92 900 mm²).
 - 1.2. The material used to fill the annular space shall prevent the passage of flame and hot gases sufficient to ignite cotton waste where subjected to ASTM E119 or UL 263 time temperature fire conditions under a positive pressure differential of not less than 0.01 inch of water (3 Pa) at the location of the penetration for the time period equivalent to the fire-resistance rating of the construction penetrated.
2. The annular space created by the penetration of water-filled fire sprinkler piping, provided that the annular space is filled using a material complying with Item 1.2 of Exception 1.

Proponent: BOASC

Previous Code Cycles	Previous Modification Index Number	Previous Code Section
N/A		



South Carolina Department of Labor, Licensing and Regulation
South Carolina Building Codes Council
2021 Modification Index

Applicable Code: 2021 International Residential Code

Modification Index Number: IRC 2021-10

Code Section: R302.5.1 Opening protection

Modification:

R302.5.1 Opening protection. Openings from a private garage directly into a room used for sleeping purposes shall not be permitted. Other openings between the garage and residence shall be equipped with solid wood doors not less than 1³/₈ inches (35 mm) in thickness, solid or honeycomb-core steel doors not less than 1³/₈ inches (35 mm) thick, or 20-minute fire-rated doors. ~~Doors shall be self-latching and equipped with a self-closing or automatic-closing device.~~

Proponent: Home Builders Association of South Carolina

Previous Code Cycles	Previous Modification Index Number	Previous Code Section
IRC 2018	IRC 2018 05	R302.5.1
IRC 2015	IRC 2015 05	R302.5.1



South Carolina Department of Labor, Licensing and Regulation
South Carolina Building Codes Council
2021 Modification Index

Applicable Code: 2021 International Residential Code

Modification Index Number: IRC 2021-11

Code Section: R302.13 Fire protection of floors

Modification:

R302.13 Fire protection of floors. Floor assemblies that are not required elsewhere in this code to be fire-resistance rated, shall be provided with a 1/2-inch (12.7 mm) gypsum wallboard membrane, 5/8-inch (16 mm) *wood structural panel* membrane, or equivalent on the underside of the floor framing member. Penetrations or openings for ducts, vents, electrical outlets, lighting, devices, luminaires, wires, speakers, drainage, piping and similar openings or penetrations shall be permitted.

Exceptions:

1. Floor assemblies located directly over a space protected by an automatic sprinkler system in accordance with Section P2904, NFPA 13D, or other *approved* equivalent sprinkler system.
2. ~~Floor assemblies located directly over a crawl space not intended for storage or for the installation of fuel-fired or electric-powered heating appliances.~~ Floor assemblies located directly over a crawl space.
3. Portions of floor assemblies shall be permitted to be unprotected where complying with the following:
 - 3.1. The aggregate area of the unprotected portions does not exceed 80 square feet (7.4 m²) per story.
 - 3.2. Fireblocking in accordance with Section R302.11.1 is installed along the perimeter of the unprotected portion to separate the unprotected portion from the remainder of the floor assembly.
4. Wood floor assemblies using dimension lumber or *structural composite lumber* equal to or greater than 2-inch by 10-inch (50.8 mm by 254 mm) nominal dimension, or other *approved* floor assemblies demonstrating equivalent fire performance.

Proponent: Home Builders Association of South Carolina

Previous Code Cycles	Previous Modification Index Number	Previous Code Section
IRC 2018	IRC 2018 06	R302.13
IRC 2015	IRC 2015 06	R302.13



South Carolina Department of Labor, Licensing and Regulation
South Carolina Building Codes Council
2021 Modification Index

Applicable Code: 2021 International Residential Code

Modification Index Number: IRC 2021-12

Code Section: R303.4 Mechanical ventilation

Modification:

R303.4 Mechanical ventilation. Buildings and *dwelling units* complying with Section N1102.4.1 shall be provided with mechanical ventilation in accordance with Section M1505, or with other *approved* means of ventilation.

(Section deleted without substitution)

Proponent: Coastal Code Enforcement Association of SC

Previous Code Cycles	Previous Modification Index Number	Previous Code Section
IRC 2018	IRC 2018 07	R303.4
IRC 2015	IRC 2015 07	R303.4
IRC 2012	IRC 2012 05	R303.4



South Carolina Department of Labor, Licensing and Regulation
South Carolina Building Codes Council
2021 Modification Index

Applicable Code: 2021 International Residential Code

Modification Index Number: IRC 2021-13

Code Section: Figure R307.1 Minimum Fixture Clearances

Modification:

Change the minimum dimension for the side clearance between bathtub and water closet or bidet from 15 inches to 12 inches. See Figure on next page.

Proponent: Home Builders Association of South Carolina

Previous Code Cycles	Previous Modification Index Number	Previous Code Section
IRC 2018	IRC 2018 08	Figure R307.1
IRC 2015	IRC 2015 08	Figure R307.1
IRC 2012	IRC 2012 06	Figure R307.1
IRC 2006	IRC 2006 09	Figure R307.1
IRC 2003	IRC 2003 05	Figure R307.2

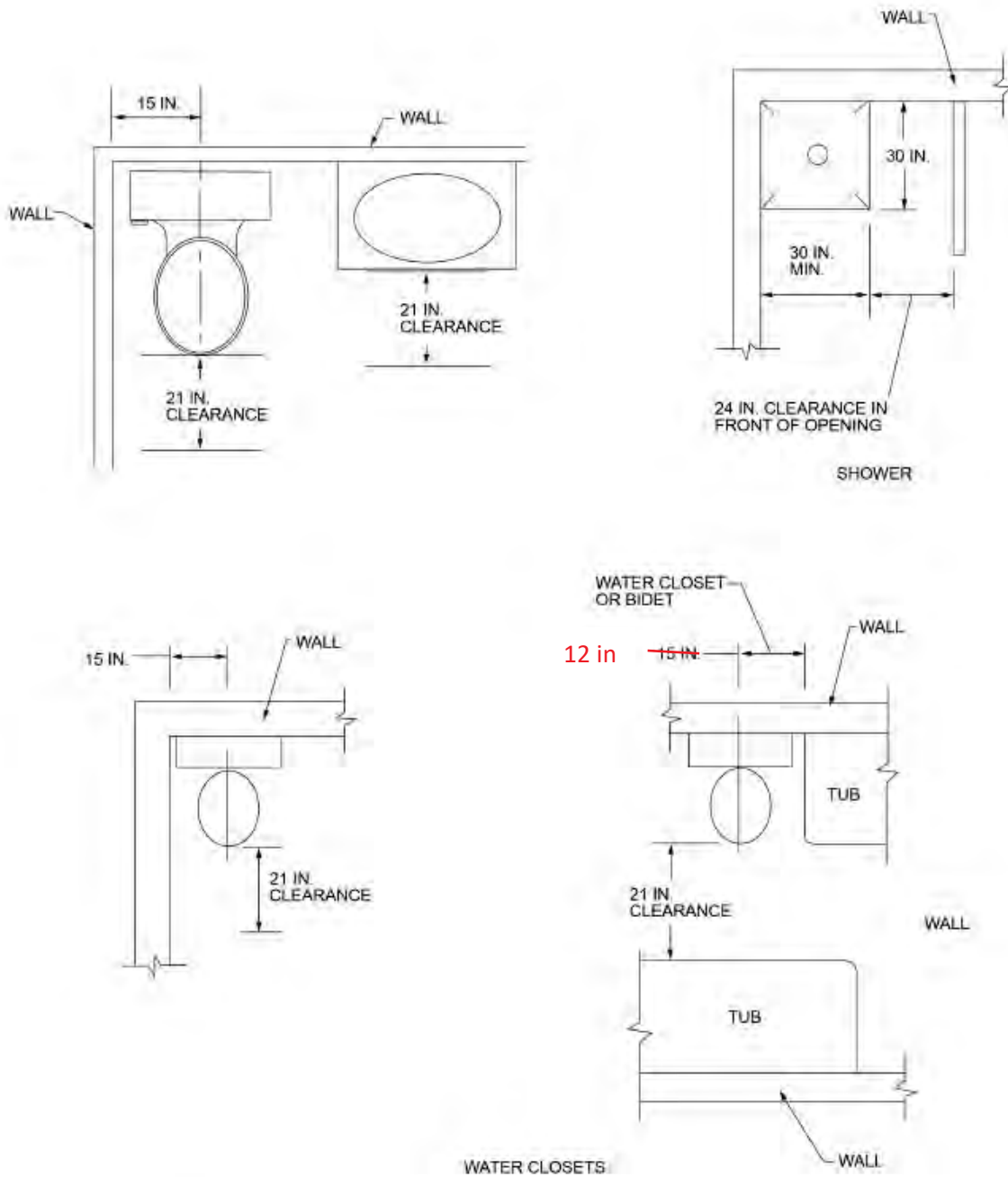

For SI: 1 inch = 25.4 mm

FIGURE R307.1
MINIMUM FIXTURE CLEARANCES



South Carolina Department of Labor, Licensing and Regulation
South Carolina Building Codes Council
2021 Modification Index

Applicable Code: 2021 International Residential Code

Modification Index Number: IRC 2021-15

Code Section: R311.7.5.1 Risers

Modification:

R311.7.5.1 Risers. The maximum riser height shall be ~~not more than 7¾ inches (196 mm).~~ The maximum riser height for masonry stairs shall be 8 inches (203 mm). The *riser* height shall be measured vertically between leading edges of the adjacent treads. The greatest *riser* height within any flight of stairs shall not exceed the smallest by more than 3/8 inch (9.5 mm). *Risers* shall be vertical or sloped from the underside of the *nosing* of the tread above at an angle not more than 30 degrees (0.51 rad) from the vertical. At open *risers*, openings located more than 30 inches (762 mm), as measured vertically, to the floor or *grade* below shall not permit the passage of a 4-inch-diameter (102 mm) sphere.

Exceptions:

1. The opening between adjacent treads is not limited on ~~*spiral stairways*~~ stairs with a total rise of 30 inches (762 mm) or less.
2. The *riser* height of *spiral stairways* shall be in accordance with Section R311.7.10.1.

Proponent: Structural Engineers Association of South Carolina

Previous Code Cycles	Previous Modification Index Number	Previous Code Section
IRC 2018	IRC 2018 09	R311.7.5.1
IRC 2015	IRC 2015 09	R311.7.5.1
IRC 2012	IRC 2012 07	R311.7.5.1



South Carolina Department of Labor, Licensing and Regulation
South Carolina Building Codes Council
2021 Modification Index

Applicable Code: 2021 International Residential Code

Modification Index Number: IRC 2021-16

Code Section: R312.1.1 Where required

Modification:

R312.1.1 Where required. *Guards* shall be provided for those portions of open-sided walking surfaces, including floors, stairs, *ramps* and landings that are located more than 30 inches (762 mm) measured vertically to the floor or *grade* below at any point within 36 inches (914 mm) horizontally to the edge of the open side. Insect screening shall not be considered as a *guard*.

Guards shall be located along open sided walking surfaces of all decks, porches, balconies, floors, stairs, ramps and landings that are located more than 30 inches measured vertically to the floor or grade below and at any point where a downward slope exceeds 3V:12H within 36 inches (914 mm) horizontally to the edge of the open side. Insect screening shall not be considered as a guard.

Proponent: Home Builders Association of South Carolina

Previous Code Cycles	Previous Modification Index Number	Previous Code Section
IRC 2018	IRC 2018 10	R312.1.1
IRC 2015	IRC 2015 10	R312.1.1
IRC 2012	IRC 2012 08	R312.1.1



South Carolina Department of Labor, Licensing and Regulation
South Carolina Building Codes Council
2021 Modification Index

Applicable Code: 2021 International Residential Code

Modification Index Number: IRC 2021-17

Code Section: R312.2 Window fall protection

Modification:

R312.2 Window fall protection. Window fall protection shall be provided in accordance with Sections R312.2.1 and R312.2.2

Deleted without substitution.

Proponent: Home Builders Association of South Carolina

Previous Code Cycles	Previous Modification Index Number	Previous Code Section
IRC 2018	IRC 2018 11	R312.2
IRC 2015	IRC 2015 11	R312.2
IRC 2012	IRC 2012 09	R312.2



South Carolina Department of Labor, Licensing and Regulation
South Carolina Building Codes Council
2021 Modification Index

Applicable Code: 2021 International Residential Code

Modification Index Number: IRC 2021-18

Code Section: R313 Automatic Fire Sprinkler Systems

Modification:

SECTION R313

AUTOMATIC FIRE SPRINKLER SYSTEMS

R313.1 Townhouse automatic fire sprinkler systems. An automatic residential fire sprinkler system shall not be required to be installed in townhouses when constructed in accordance with R302.2.

Exception: An automatic residential fire sprinkler system shall not be required where *additions* or *alterations* are made to existing *townhouses* that do not have an automatic residential fire sprinkler system installed.

R313.1.1 Design and installation. Automatic residential fire sprinkler systems for *townhouses* when installed shall be designed and installed in accordance with Section P2904 or NFPA 13D.

R313.2 One- and two-family dwellings automatic sprinkler systems. An automatic residential fire sprinkler system shall be installed shall not be required to be installed in one- and two-family dwellings.

Exception: An automatic residential fire sprinkler system shall not be required for *additions* or *alterations* to existing buildings that are not already provided with an automatic residential fire sprinkler system.

R313.2.1 Design and installation. Automatic residential fire sprinkler systems when installed shall be designed and installed in accordance with Section P2904 or NFPA 13D.

Proponent: Home Builders Association of South Carolina

Previous Code Cycles	Previous Modification Index Number	Previous Code Section
IRC 2018	IRC 2018 12	R313
IRC 2015	IRC 2015 12	R313
IRC 2012	IRC 2012 10	R313.1
IRC 2012	IRC 2012 11	R313.2



South Carolina Department of Labor, Licensing and Regulation
South Carolina Building Codes Council
2021 Modification Index

Applicable Code: 2021 International Residential Code

Modification Index Number: IRC 2021-22

Code Section: R317.1.1 Field treatment

Modification:

R317.1.1 Field treatment. Field-cut ends, notches and drilled holes of preservative-treated wood shall be treated in the field in accordance with AWP A M4 or in accordance with the preservative-treated wood product manufacturer's recommendations.

Proponent: Structural Engineers Association of South Carolina

Previous Code Cycles	Previous Modification Index Number	Previous Code Section
IRC 2018	IRC 2018 14	R317.1.1
IRC 2015	IRC 2015 13	R317.1.1
IRC 2012	IRC 2012 12	R317.1.1



South Carolina Department of Labor, Licensing and Regulation
South Carolina Building Codes Council
2021 Modification Index

Applicable Code: 2021 International Residential Code

Modification Index Number: IRC 2021-23

Code Section: R318.1 Subterranean termite control methods

Modification:

R318.1 Subterranean termite control methods. In areas subject to damage from termites as indicated by Table R301.2, protection shall be by one, or a combination, of the following methods:

1. Chemical termiticide treatment in accordance with Section R318.2.
2. Termite-baiting system installed and maintained in accordance with the *label*.
3. Pressure-preservative-treated wood in accordance with the provisions of Section R317.1.
4. Naturally durable termite-resistant wood.
5. Physical barriers in accordance with Section R318.3 and used in locations as specified in Section R317.1.
6. Cold-formed steel framing in accordance with Sections R505.2.1 and R603.2.1.
7. Treatments may be conducted as outlined in Section 27-1085 of the Rules and Regulations for the Enforcement of the SC Pesticide Control Act and enforced by the Clemson University Department of Pesticide Regulation.

Proponent: Home Builders Association of SC

Previous Code Cycles	Previous Modification Index Number	Previous Code Section
IRC 2018	IRC 2018 15	R318.1



South Carolina Department of Labor, Licensing and Regulation
South Carolina Building Codes Council
2021 Modification Index

Applicable Code: 2021 International Residential Code

Modification Index Number: IRC 2021-24

Code Section: R318.4 Foam plastic protection

Modification:

R318.4 Foam plastic protection. In areas where the probability of termite infestation is “very heavy” as indicated in Figure R318.4, extruded and expanded polystyrene, polyisocyanurate and other foam plastics shall not be installed on the exterior face or under interior or exterior foundation walls or slab foundations located below *grade*. The clearance between foam plastics installed above *grade* and exposed earth shall be not less than 6 inches (152 mm). For crawl space applications, foam plastic shall be installed so as to provide a termite inspection gap of no less than 6 inches along the top of the foundation wall and foundation sill plate.

Exceptions:

1. Buildings where the structural members of walls, floors, ceilings and roofs are entirely of *noncombustible materials* or pressure-preservative-treated wood.
2. Where in addition to the requirements of Section R318.1, an *approved* method of protecting the foam plastic and structure from subterranean termite damage is used.
3. On the interior side of basement *walls*.

Proponent: Home Builders Association of South Carolina

Previous Code Cycles	Previous Modification Index Number	Previous Code Section
IRC 2018	IRC 2018 16	R318.4



South Carolina Department of Labor, Licensing and Regulation
South Carolina Building Codes Council
2021 Modification Index

Applicable Code: 2021 International Residential Code

Modification Index Number: IRC 2021-25

Code Section: R318.5 Termite Inspection Strip

Modification:

R318.5 Termite Inspection Strip. Where foam plastic is applied in accordance with R318.4 a continuous 6” strip centered along the sill plate shall be left open for termite activity inspection.

Proponent: Home Builders Association of South Carolina

Previous Code Cycles	Previous Modification Index Number	Previous Code Section
N/A		



South Carolina Department of Labor, Licensing and Regulation
South Carolina Building Codes Council
2021 Modification Index

Applicable Code: 2021 International Residential Code

Modification Index Number: IRC 2021-28

Code Section: R322.1 General

Modification:

R322.1 General. Buildings and structures constructed in whole or in part in flood hazard areas, including A or V Zones and Coastal A Zones, as established in Table R301.2, and substantial improvement and *repair* of substantial damage of buildings and structures in flood hazard areas, shall be designed and constructed in accordance with the provisions contained in this section. Buildings and structures that are located in more than one flood hazard area shall comply with the provisions associated with the most restrictive flood hazard area. Buildings and structures located in whole or in part in identified floodways shall be designed and constructed in accordance with ASCE 24. Where there is a conflict with this code section and a locally adopted flood ordinance, the more restrictive provision shall apply.

Proponent: BOASC

Previous Code Cycles	Previous Modification Index Number	Previous Code Section
IRC 2018	IRC 2018 18	R322.1



South Carolina Department of Labor, Licensing and Regulation
South Carolina Building Codes Council
2021 Modification Index

Applicable Code: 2021 International Residential Code

Modification Index Number: IRC 2021-29

Code Section: R326.3 Story above grade plane

Modification:

R326.3 Story above grade plane. A habitable attic shall be considered a story above *grade plane*.

Exceptions: A habitable attic shall not be considered to be a story above *grade plane* provided that the habitable attic meets all the following:

1. The aggregate area of the habitable attic is either of the following:
 - 1.1. Not greater than ~~one-third~~ three-fourths of the floor area of the story below.
 - 1.2. Not greater than ~~one-half~~ of the floor area of the story below where the habitable attic is located within a dwelling unit equipped with a fire sprinkler system in accordance with Section P2904.
2. The occupiable space is enclosed by the roof assembly above, knee walls, if applicable, on the sides and the floor-ceiling assembly below.
3. The floor of the habitable attic does not extend beyond the exterior walls of the story below.
4. Where a habitable attic is located above a third story, the dwelling unit or townhouse unit shall be equipped with a fire sprinkler system in accordance with Section P2904.

Proponent: Home Builders Association of South Carolina

Previous Code Cycles	Previous Modification Index Number	Previous Code Section
N/A		



South Carolina Department of Labor, Licensing and Regulation
South Carolina Building Codes Council
2021 Modification Index

Applicable Code: 2021 International Residential Code

Modification Index Number: IRC 2021-31

Code Section: R404.1.9.2 Masonry piers supporting floor girders

Modification:

R404.1.9.2 Masonry piers supporting floor girders. Masonry piers supporting wood girders sized in accordance with Tables R602.7(1) and R602.7(2) shall be permitted in accordance with this section. Piers supporting girders for interior bearing walls shall have a minimum nominal dimension of 12 inches (305 mm) and a maximum height of 10 feet (3048 mm) be filled solidly with grout or type M or S mortar and shall have a minimum nominal dimension of 8 inches (203 mm) and a maximum height not exceeding 10 times the nominal thickness from top of footing to bottom of sill plate or girder. Piers supporting girders for exterior bearing walls shall have a minimum nominal dimension of 12 inches (305 mm) and a maximum height of 4 feet (1220 mm) from top of footing to bottom of sill plate or girder. Piers supporting beams and girders for exterior bearing walls shall be filled solidly with grout or type M or S mortar, shall contain a minimum of one #4 (13 mm) dowel mid-depth, and shall have a minimum nominal dimension of 8 inches (203 mm) and a maximum height of 4 times the nominal thickness from top of footing to bottom of sill plate or girder unless it can be shown by accepted engineering practice that there is sufficient foundation wall along the foundation line to resist the imposed lateral loads, in which case the maximum height shall not exceed 10 times the nominal thickness. Girders and sill plates shall be anchored to the pier or footing in accordance with Section R403.1.6 or Figure R404.1.5.3. Floor girder bearing shall be in accordance with Section R502.6.

Proponent: HBA of SC & Structural Engineers Association of SC

Previous Code Cycles	Previous Modification Index Number	Previous Code Section
IRC 2018	IRC 2018 20	R404.1.9.2
IRC 2015	IRC 2015 16	R404.1.9.2
IRC 2012	IRC 2012 13	R404.1.9.2



South Carolina Department of Labor, Licensing and Regulation
South Carolina Building Codes Council
2021 Modification Index

Applicable Code: 2021 International Residential Code

Modification Index Number: IRC 2021-32

Code Section: R408.3 Unvented crawl space

Modification:

R408.3 Unvented crawl space. For unvented under-floor spaces, the following items shall be provided:

1. Exposed earth shall be covered with a continuous ~~Class I~~ vapor retarder meeting ASTM E1745 Class A. Joints of the vapor retarder shall overlap by 6 inches (152 mm) and shall be sealed or taped. The edges of the vapor retarder shall extend not less than 6 inches (152 mm) up the stem wall and shall be attached and sealed to the stem wall or insulation.
2. One of the following shall be provided for the under-floor space:
 - 2.1. Continuously operated mechanical exhaust ventilation at a rate equal to 1 cubic foot per minute (0.47 L/s) for each 50 square feet (4.7m²) of *crawl space* floor area, including an air pathway to the common area (such as a duct or transfer grille), and perimeter walls insulated in accordance with Section N1102.2.10.1 of this code.
 - 2.2. *Conditioned air* supply sized to deliver at a rate equal to 1 cubic foot per minute (0.47 L/s) for each 50 square feet (4.7 m²) of under-floor area, including a return air pathway to the common area (such as a duct or transfer grille), and perimeter walls insulated in accordance with Section N1102.2.10.1 of this code.
 - 2.3. Plenum in existing structures complying with Section M1601.5, if under-floor space is used as a plenum.
 - 2.4. Dehumidification sized in accordance with manufacturer's specifications.

Proponent: Structural Engineers Association of South Carolina

Previous Code Cycles	Previous Modification Index Number	Previous Code Section
IRC 2018	IRC 2018 21	R408.3



South Carolina Department of Labor, Licensing and Regulation
South Carolina Building Codes Council
2021 Modification Index

Applicable Code: 2021 International Residential Code

Modification Index Number: IRC 2021-33

Code Section: R408.3(2.2) Unvented crawl space

Modification:

R408.3 Unvented crawl space. For unvented under-floor spaces, the following items shall be provided:

1. Exposed earth shall be covered with a continuous vapor retarder meeting ASME E1745 Class A. Joints of the vapor retarder shall overlap by 6 inches (152 mm) and shall be sealed or taped. The edges of the vapor retarder shall extend not less than 6 inches (152 mm) up the stem wall and shall be attached and sealed to the stem wall or insulation.
2. One of the following shall be provided for the underfloor space:
 - 2.1. Continuously operated mechanical exhaust ventilation at a rate equal to 1 cubic foot per minute (0.47 L/s) for each 50 square feet (4.7m²) of *crawl space* floor area, including an air pathway to the common area (such as a duct or transfer grille), and perimeter walls insulated in accordance with Section N1102.2.10.1 of this code.
 - 2.2. *Conditioned air* supply sized to deliver at a rate equal to 1 cubic foot per minute (0.47 L/s) for each 50 square feet (4.7 m²) of underfloor area, including a return air pathway to the common area (such as a duct or transfer grille), and perimeter walls insulated in accordance with ~~Section N1102.2.10.1 of this code~~ the S.C. Energy Code.
 - 2.3. Plenum in existing structures complying with Section M1601.5, if under-floor space is used as a plenum.
 - 2.4. Dehumidification sized in accordance with manufacturer's specifications.

Proponent: Home Builders Association of South Carolina

Previous Code Cycles	Previous Modification Index Number	Previous Code Section
N/A		



South Carolina Department of Labor, Licensing and Regulation
South Carolina Building Codes Council
2021 Modification Index

Applicable Code: 2021 International Residential Code

Modification Index Number: IRC 2021-34

Code Section: R408.4 Access

Modification:

R408.4 Access. Access shall be provided to all under-floor spaces. Access openings through the floor shall be not smaller than 18 inches by 24 inches (457 mm by 610 mm). Openings through a perimeter wall shall be not less than 16 inches by 24 inches (407 mm by 610 mm). Where any portion of the through-wall access is below *grade*, an areaway not less than 16 inches by 24 inches (407 mm by 610 mm) shall be provided. The bottom of the areaway shall be below the threshold of the access opening. ~~Through wall access openings shall not be located under a door to the residence.~~ See Section M1305.1.3 for access requirements where mechanical *equipment* is located under floors.

Proponent: Home Builders Association of South Carolina

Previous Code Cycles	Previous Modification Index Number	Previous Code Section
IRC 2018	IRC 2018 22	R408.4
IRC 2015	IRC 2015 17	R408.4



South Carolina Department of Labor, Licensing and Regulation
South Carolina Building Codes Council
2021 Modification Index

Applicable Code: 2021 International Residential Code

Modification Index Number: IRC 2021-35

Code Section: R408.8 Under-floor vapor retarder

Modification:

R408.8 Under-floor vapor retarder. In Climate Zones 1A, 2A and 3A below the warm-humid line, a continuous Class I or II vapor retarder shall be provided on the exposed face of air-permeable insulation installed between the floor joists and exposed to the grade in the under-floor space. The vapor retarder shall have a maximum water vapor permeance of 1.5 perms when tested in accordance with Procedure B of ASTM E96.

Exception: The vapor retarder shall not be required in unvented *crawl spaces* constructed in accordance with Section R408.3.

Deleted without substitution.

Proponent: Home Builders Association of South Carolina

Previous Code Cycles	Previous Modification Index Number	Previous Code Section
N/A		



South Carolina Department of Labor, Licensing and Regulation
South Carolina Building Codes Council
2021 Modification Index

Applicable Code: 2021 International Residential Code

Modification Index Number: IRC 2021-36

Code Section: R502.11.4 Truss design drawings

Modification:

R502.11.4 Truss design drawings. *Truss design drawings*, prepared in compliance with Section R502.11.1, shall be submitted to the *building official* ~~and approved prior to installation at the time of their inspection.~~ *Truss design drawings* shall be provided with the shipment of trusses delivered to the job site. *Truss design drawings* shall include, at a minimum, the information specified as follows:

1. Slope or depth, span and spacing.
2. Location of all joints.
3. Required bearing widths.
4. Design loads as applicable:
 - 4.1. Top chord *live load*.
 - 4.2. Top chord dead load.
 - 4.3. Bottom chord *live load*.
 - 4.4. Bottom chord dead load.
 - 4.5. Concentrated loads and their points of application.
 - 4.6. Controlling wind and earthquake loads.
5. Adjustments to lumber and joint connector design values for conditions of use.
6. Each reaction force and direction.
7. Joint connector type and description, such as size, thickness or gage, and the dimensioned location of each joint connector except where symmetrically located relative to the joint interface.
8. Lumber size, species and grade for each member.
9. Connection requirements for:
 - 9.1. Truss-to-girder-truss.
 - 9.2. Truss ply-to-ply.
 - 9.3. Field splices.
10. Calculated deflection ratio, maximum description for live and total load, or both.
11. Maximum axial compression forces in the truss members to enable the building designer to design the size, connections and anchorage of the permanent continuous lateral bracing. Forces shall be shown on the truss drawing or on supplemental documents.
12. Required permanent truss member bracing location.

Proponent: Home Builders Association of South Carolina

Previous Code Cycles	Previous Modification Index Number	Previous Code Section
IRC 2018	IRC 2018 23	R502.11.4
IRC 2015	IRC 2015 18	R502.11.4
IRC 2012	IRC 2012 14	R502.11.4
IRC 2006	IRC 2006 21	R502.11.4
IRC 2003	IRC 2003 17	R502.11.4



South Carolina Department of Labor, Licensing and Regulation
South Carolina Building Codes Council
2021 Modification Index

Applicable Code: 2021 International Residential Code

Modification Index Number: IRC 2021-37

Code Section: R506.2.3 Vapor retarder

Modification:

R506.2.3 Vapor retarder. A minimum 10-mil (0.010 inch; 0.254 mm) vapor retarder conforming to ASTM E1745 Class A requirements with joints lapped not less than 6 inches (152 mm) shall be placed between the concrete floor slab and the base course or the prepared subgrade where a base course does not exist.

Exception: The vapor retarder is not required for the following:

1. ~~Garages~~, utility buildings and other unheated *accessory structures*.
2. For unheated storage rooms having an area of less than 70 square feet (6.5 m²) and carports.
3. Driveways, walks, patios and other flatwork not likely to be enclosed and heated at a later date.
4. Where *approved* by the *building official*, based on local site conditions.

Proponent: Structural Engineers Association of South Carolina

Previous Code Cycles	Previous Modification Index Number	Previous Code Section
IRC 2018	IRC 2018 24	R506.2.3
IRC 2015	IRC 2015 19	R506.2.3



South Carolina Department of Labor, Licensing and Regulation
South Carolina Building Codes Council
2021 Modification Index

Applicable Code: 2021 International Residential Code

Modification Index Number: IRC 2021-38

Code Section: R606.7 Piers

Modification:

R606.7 Piers. The unsupported height of masonry piers shall not exceed 10 times their least dimension. Where structural clay tile or hollow *concrete masonry units* are used for isolated piers to support beams and girders, the cellular spaces shall be filled solidly with grout or Type M or S mortar, except that unfilled hollow piers shall be permitted to be used if their unsupported height is not more than four times their least dimension. Where *hollow masonry units* are solidly filled with grout or Type M, S or N mortar, the allowable compressive stress shall be permitted to be increased as provided in Table R606.9.

Proponent: Structural Engineers Association of South Carolina

Previous Code Cycles	Previous Modification Index Number	Previous Code Section
IRC 2018	IRC 2018 25	R606.7
IRC 2015	IRC 2015 20	R606.7



South Carolina Department of Labor, Licensing and Regulation
South Carolina Building Codes Council
2021 Modification Index

Applicable Code: 2021 International Residential Code

Modification Index Number: IRC 2021-39

Code Section: R802.10.1 Truss design drawings

Modification:

R802.10.1 Truss design drawings. *Truss design drawings*, prepared in conformance to Section R802.10.1, shall be provided to the *building official* and ~~approved prior to installation~~ at the time of their inspection. *Truss design drawings* shall be provided with the shipment of trusses delivered to the job site. *Truss design drawings* shall include, at a minimum, the following information:
 (items 1-12 unchanged)

Proponent: Home Builders Association of South Carolina

Previous Code Cycles	Previous Modification Index Number	Previous Code Section
IRC 2018	IRC 2018 26	R802.10.1
IRC 2015	IRC 2015 21	R802.10.1



South Carolina Department of Labor, Licensing and Regulation
South Carolina Building Codes Council
2021 Modification Index

Applicable Code: 2021 International Residential Code

Modification Index Number: IRC 2021-40

Code Section: R905.2.8.5 Drip edge

Modification:

R905.2.8.5 Drip edge. A drip edge shall be provided at eaves and rake edges of shingle roofs. Adjacent segments of drip edge shall be overlapped not less than 2 inches (51 mm). Drip edges shall extend not less than 1/4 inch (6.4 mm) below the roof sheathing and extend up back onto the *roof deck* not less than 2 inches (51 mm). Drip edges shall be mechanically fastened to the *roof deck* at not more than 12 inches (305 mm) o.c. with fasteners as specified in Section R905.2.5. *Underlayment* shall be installed over the drip edge along eaves and under the drip edge along rake edges. A drip edge shall be provided at eaves and rake edges of asphalt shingle roofs where required by the manufacturer.

Proponent: Home Builders Association of South Carolina

Previous Code Cycles	Previous Modification Index Number	Previous Code Section
IRC 2018	IRC 2018 27	R905.2.8.5
IRC 2015	IRC 2015 22	R905.2.8.5



South Carolina Department of Labor, Licensing and Regulation
South Carolina Building Codes Council
2021 Modification Index

Applicable Code: 2021 International Residential Code

Modification Index Number: IRC 2021-41

Code Section: Chapter 11 Energy Efficiency

Modification:

**CHAPTER 11 [RE]
ENERGY EFFICIENCY**

Chapter deleted without substitution. The State of South Carolina has specific energy standards in statutory form (Re: Title 6, Chapter 9, Building Codes and Title 6, Chapter 10, Building Energy Efficiency Standard Act). To eliminate any possible conflicts concerning the insulation requirements for single and two family residential buildings between the International Residential Code and state law, Chapter 11 was deleted.

Proponent: Home Builders Association of South Carolina

Previous Code Cycles	Previous Modification Index Number	Previous Code Section
IRC 2018	IRC 2018 28	Chapter 11
IRC 2015	IRC 2015 22	Chapter 11
IRC 2012	IRC 2012 16	Chapter 11
IRC 2006	IRC 2006 27	Chapter 11
IRC 2003	IRC 2003 21	Chapter 11



South Carolina Department of Labor, Licensing and Regulation
South Carolina Building Codes Council
2021 Modification Index

Applicable Code: 2021 International Residential Code

Modification Index Number: IRC 2021-42

Code Section: M1411.6 Insulation and refrigerant piping

Modification:

M1411.6 Insulation of refrigerant piping. Piping and fittings for refrigerant vapor (suction) lines shall be insulated with insulation having a thermal resistivity of ~~not less than R-3~~ at least R 2.5 hr. ft 2 F/Btu and having external surface permeance not exceeding 0.05 perm [2.87 ng/(s × m² × Pa)] when tested in accordance with ASTM E96.

Proponent: Home Builders Association of South Carolina

Previous Code Cycles	Previous Modification Index Number	Previous Code Section
IRC 2018	IRC 2018 29	M1411.6
IRC 2015	IRC 2015 24	M1411.6
IRC 2012	IRC 2012 18	M1411.6
IRC 2006	IRC 2006 28	M1411.5
IRC 2003	IRC 2003 22	M1411.4



South Carolina Department of Labor, Licensing and Regulation
South Carolina Building Codes Council
2021 Modification Index

Applicable Code: 2021 International Residential Code

Modification Index Number: IRC 2021-43

Code Section: M1411.9 Locking access port caps

Modification:

M1411.9 Locking access port caps. Refrigerant circuit access ports located outdoors shall be fitted with locking type tamper-resistant caps or shall be otherwise secured to prevent unauthorized access.

Deleted without substitution.

Proponent: Home Builders Association of South Carolina

Previous Code Cycles	Previous Modification Index Number	Previous Code Section
IRC 2018	IRC 2018 30	M1411.8
IRC 2015	IRC 2015 25	M1411.6
IRC 2012	IRC 2012 18	M1411.6



South Carolina Department of Labor, Licensing and Regulation
South Carolina Building Codes Council
2021 Modification Index

Applicable Code: 2021 International Residential Code

Modification Index Number: IRC 2021-44

Code Section: M1502.3 Duct termination

Modification:

M1502.3 Duct termination. Exhaust ducts shall terminate on the outside of the building. Exhaust duct terminations shall be in accordance with the dryer manufacturer's installation instructions. ~~If the manufacturer's instructions do not specify a termination location, the exhaust duct shall terminate not less than 3 feet (914 mm) in any direction from openings into buildings, including openings in ventilated soffits.~~ Exhaust duct terminations shall be equipped with a backdraft damper. Screens shall not be installed at the duct termination.

Proponent: Home Builders Association of South Carolina

Previous Code Cycles	Previous Modification Index Number	Previous Code Section
IRC 2018	IRC 2018 31	M1502.3
IRC 2015	IRC 2015 26	M1502.3
IRC 2012	IRC 2012 19	M1502.3
IRC 2006	IRC 2006 29	M1502.2



South Carolina Department of Labor, Licensing and Regulation
South Carolina Building Codes Council
2021 Modification Index

Applicable Code: 2021 International Residential Code

Modification Index Number: IRC 2021-45

Code Section: M1502.4.2 Duct installation

Modification:

M1502.4.2 Duct installation. Exhaust ducts shall be supported at intervals not to exceed 8 feet and within 16 inches of each side of a joint that is not installed in a vertical orientation, 12 feet (3658 mm) and shall be secured in place, making rigid contact with the duct at not less than 4 equally spaced points or 2/3rds contact if strap is used. All brackets or strapping must be noncombustible. The insert end of the duct shall extend into the adjoining duct or fitting in the direction of airflow. The overlap shall comply with Section M1601.4.2. Ducts shall not be joined with screws or similar devices that protrude into the inside of the duct. Exhaust ducts joints shall be sealed in accordance with Section M1601.4.1. and shall be mechanically fastened. Ducts shall not be joined with screws or similar fasteners that protrude more than 1/8 inch (3.2 mm) into the inside of the duct. Where dryer exhaust ducts are enclosed in wall or ceiling cavities, such cavities shall allow the installation of the duct without deformation. The duct work may be ovalized as long as it terminates in an approved duct box. Minor imperfections located on the duct, in areas other than along the seam, do not constitute a violation.

Proponent: Home Builders Association of South Carolina

Previous Code Cycles	Previous Modification Index Number	Previous Code Section
IRC 2018	IRC 2018 32	M1502.4.2



South Carolina Department of Labor, Licensing and Regulation
South Carolina Building Codes Council
2021 Modification Index

Applicable Code: 2021 International Residential Code

Modification Index Number: IRC 2021-46

Code Section: M1502.4.6 Duct length

Modification:

M1502.4.6 Duct length. ~~The maximum allowable exhaust duct length shall be determined by one of the methods specified in Sections M1502.4.6.1 through M1502.4.6.3. The maximum length of a clothes dryer exhaust duct shall not exceed 35 feet (10668 mm) from the dryer location to the wall or roof termination.~~

Proponent: Home Builders Association of South Carolina

Previous Code Cycles	Previous Modification Index Number	Previous Code Section
IRC 2018	IRC 2018 33	M1502.4.5
IRC 2015	IRC 2015 27	M1502.4.4
IRC 2012	IRC 2012 20	M1502.4.4
IRC 2006	IRC 2006 30	M1502.6



South Carolina Department of Labor, Licensing and Regulation
South Carolina Building Codes Council
2021 Modification Index

Applicable Code: 2021 International Residential Code

Modification Index Number: IRC 2021-47

Code Section: M1503.6 Makeup air

Modification:

M1503.6 Makeup air required. Where one or more gas, liquid or solid fuel-burning *appliance* that is neither directvent nor uses a mechanical draft venting system is located within a dwelling unit's air barrier, each exhaust system capable of exhausting in excess of 400 cubic feet per minute (0.19 m³/s) shall be mechanically or passively provided with makeup air at a rate approximately equal to the exhaust air rate. Such makeup air systems shall be equipped with not fewer than one damper complying with Section M1503.6.2.

Exception: Makeup air is not required for exhaust systems installed for the exclusive purpose of space cooling and intended to be operated only when windows or other air inlets are open.

Exhaust hood systems capable of exhausting more than 400 cubic feet per minute (0.19m³ /s) shall be mechanically or naturally provided with makeup air at a rate approximately equal to the exhaust air rate more than 400 cubic feet per minute. Such makeup air systems shall be equipped with not less than one damper. Each damper shall be a gravity damper or an electrically operated damper that automatically opens when the exhaust system operates. Dampers shall be accessible for inspection, service, repair and replacement without removing permanent construction or any other ducts not connected to the damper being inspected, serviced, repaired or replaced.

Proponent: Home Builders Association of South Carolina

Previous Code Cycles	Previous Modification Index Number	Previous Code Section
IRC 2018	IRC 2018 34	M1503.6
IRC 2015	IRC 2015 28	M1503.4



South Carolina Department of Labor, Licensing and Regulation
South Carolina Building Codes Council
2021 Modification Index

Applicable Code: 2021 International Residential Code

Modification Index Number: IRC 2021-48

Code Section: M1504.3 Exhaust openings

Modification:

M1504.3 Exhaust openings. Air exhaust openings shall terminate as follows:

1. Not less than 3 feet (914 mm) from property lines.
2. Not less than 3 feet (914 mm) from gravity air intake openings, operable windows and doors.
3. Not less than 10 feet (3048 mm) from mechanical air intake openings except where the exhaust opening is located not less than 3 feet (914 mm) above the air intake opening. Openings shall comply with Sections R303.5.2 and R303.6.

Exception: Bathrooms, water closets and shower spaces.

Proponent: Home Builders Association of South Carolina

Previous Code Cycles	Previous Modification Index Number	Previous Code Section
IRC 2018	IRC 2018 35	M1504.3



South Carolina Department of Labor, Licensing and Regulation
South Carolina Building Codes Council
2021 Modification Index

Applicable Code: 2021 International Residential Code

Modification Index Number: IRC 2021-49

Code Section: M1601.4.1 Joints, Seams and Connections

Modification:

M1601.4.1 Joints, seams and connections. Longitudinal and transverse joints, seams and connections in metallic and nonmetallic ducts shall be constructed as specified in SMACNA *HVAC Duct Construction Standards --Metal and Flexible* and NAIMA *Fibrous Glass Duct Construction Standards*. Joints, longitudinal and transverse seams, and connections in ductwork shall be securely fastened and sealed with welds, gaskets, mastics (adhesives), mastic plus-embedded-fabric systems, liquid sealants or tapes. Tapes and mastics used to seal fibrous glass ductwork shall be *listed* and *labeled* in accordance with UL 181A and shall be marked “181A-P” for pressure sensitive tape, “181 A-M” for mastic or “181 A-H” for heat-sensitive tape.

Tapes and mastics used to seal metallic and flexible air ducts and flexible air connectors shall comply with UL 181B and shall be marked “181 B-FX” for pressure-sensitive tape or “181 BM” for mastic. Duct connections to flanges of air distribution system *equipment* shall be sealed and mechanically fastened. Mechanical fasteners for use with flexible nonmetallic air ducts shall comply with UL 181B and shall be marked 181B-C. Crimp joints for round metallic ducts shall have a contact lap of not less than 1 inch (25 mm) and shall be mechanically fastened by means of not less than three sheet-metal screws or rivets equally spaced around the joint. Closure systems used to seal all ductwork shall be installed in accordance with the manufacturers' instructions.

Exceptions:

1. Spray polyurethane foam shall be permitted to be applied without additional joint seals.
2. Where a duct connection is made that is partially without access, three screws or rivets shall be equally spaced on the exposed portion of the joint so as to prevent a hinge effect.
3. For ducts having a static pressure classification of less than 2 inches of water column (500 Pa), additional closure systems shall not be required for continuously welded joints and seams and locking-type joints and seams. ~~This exception shall not apply to snap-lock and button-lock type joints and seams that are located outside of conditioned spaces.~~

Proponent: Home Builders Association of South Carolina

Previous Code Cycles	Previous Modification Index Number	Previous Code Section
IRC 2018	IRC 2018 36	M1601.4.1
IRC 2015	IRC 2015 29	M1601.4.1



South Carolina Department of Labor, Licensing and Regulation
South Carolina Building Codes Council
2021 Modification Index

Applicable Code: 2021 International Residential Code

Modification Index Number: IRC 2021-50

Code Section: G2418.2 Design and installation

Modification:

G2418.2 (407.2) Design and installation. *Piping* shall be supported with ~~metal~~ pipe hooks, ~~metal~~ pipe straps, ~~metal~~ bands, ~~metal~~ brackets, ~~metal~~ hangers or building structural components suitable for the size of *piping*, of adequate strength and quality, and located at intervals so as to prevent or damp out excessive vibration. *Piping* shall be anchored to prevent undue strains on connected *appliances* and shall not be supported by other *piping*. Pipe hangers and supports shall conform to the requirements of MSS SP-58 and shall be spaced in accordance with Section G2424. Supports, hangers and anchors shall be installed so as not to interfere with the free expansion and contraction of the *piping* between anchors. The components of the supporting *equipment* shall be designed and installed so that they will not be disengaged by movement of the supported *piping*.

Proponent: Home Builders Association of South Carolina

Previous Code Cycles	Previous Modification Index Number	Previous Code Section
IRC 2018	IRC 2018 37	G2418.2
IRC 2015	IRC 2015 30	G2418.2
IRC 2012	IRC 2012 21	G2418.2



South Carolina Department of Labor, Licensing and Regulation
South Carolina Building Codes Council
2021 Modification Index

Applicable Code: 2021 International Residential Code

Modification Index Number: IRC 2021-51

Code Section: P2503.6 Shower liner test

Modification:

P2503.6 Shower liner test. Where shower floors and receptors are made watertight by the application of materials required by Section P2709.2, the completed liner installation shall be tested. The pipe from the shower drain shall be plugged watertight for the test. The floor and receptor area shall be filled with potable water to a depth of not less than 2 inches (51 mm) measured at the threshold. Where a threshold of not less than 2 inches (51 mm) in height does not exist, a temporary threshold shall be constructed to retain the test water in the lined floor or receptor area to a level not less than 2 inches (51 mm) in depth measured at the threshold. The water shall be retained Shower liner shall be tested to the lesser of the depth of threshold or 2” and shall be operated at normal pressure for a test period of not less than 15 minutes and there shall not be evidence of leakage.

Proponent: Home Builders Association of South Carolina

Previous Code Cycles	Previous Modification Index Number	Previous Code Section
IRC 2018	IRC 2018 38	P2503.6
IRC 2015	IRC 2015 31	P2503.6
IRC 2012	IRC 2012 22	P2503.6



South Carolina Department of Labor, Licensing and Regulation
South Carolina Building Codes Council
2021 Modification Index

Applicable Code: 2021 International Residential Code

Modification Index Number: IRC 2021-52

Code Section: P2503.6 Shower liner test

Modification:

P2503.6 Shower liner test. Where shower floors and receptors are made watertight by the application of materials required by Section P2709.2, the completed liner installation shall be tested. Shower liner shall be tested to the lesser of the depth of threshold or 2” and shall be operated at normal pressure for a test period of not less than 15 minutes and there shall not be evidence of leakage. The shower liner test shall be performed at the final plumbing inspection.

*Modification adds to modified language in IRC 2021-51.

Proponent: Home Builders Association of South Carolina

Previous Code Cycles	Previous Modification Index Number	Previous Code Section
N/A		



South Carolina Department of Labor, Licensing and Regulation
South Carolina Building Codes Council
2021 Modification Index

Applicable Code: 2021 International Residential Code

Modification Index Number: IRC 2021-53

Code Section: P2603.2.1 Protection against physical damage

Modification:

P2603.2.1 Protection against physical damage. In concealed locations, where piping, other than cast-iron or galvanized steel, is installed through holes or notches in studs, joists, rafters or similar members less than 1¼ inches (31.8 mm) from the nearest edge of the member, the pipe shall be protected by steel shield plates. Such shield plates shall have a thickness of not less than 0.0575 inch (1.463 mm) (No. 16 Gage). Such plates shall cover the area of the pipe where the member is notched or bored, and shall extend not less than 2 inches (51 mm) above sole plates and below top plates. Steel shield plates shall not be secured with nails or screws, unless required by the manufacturer.

Proponent: Home Builders Association of South Carolina

Previous Code Cycles	Previous Modification Index Number	Previous Code Section
N/A		



South Carolina Department of Labor, Licensing and Regulation
South Carolina Building Codes Council
2021 Modification Index

Applicable Code: 2021 International Residential Code

Modification Index Number: IRC 2021-54

Code Section: P2603.5 Freezing

Modification:

P2603.5 Freezing. In localities having a winter design temperature of 32°F (0°C) or lower as shown in Table R301.2 of this code, a water, soil or waste pipe shall not be installed outside of a building, in exterior walls, in *attics* or crawl spaces, or in any other place subjected to freezing temperature unless adequate provision is made to protect it from freezing by insulation or heat or both. Water service pipe shall be installed not less than 12 inches (305 mm) deep and not less than 6 inches (152 mm) below the frost line.

Proponent: Home Builders Association of South Carolina

Previous Code Cycles	Previous Modification Index Number	Previous Code Section
IRC 2018	IRC 2018 39	P2603.5
IRC 2015	IRC 2015 32	P2603.5



South Carolina Department of Labor, Licensing and Regulation
South Carolina Building Codes Council
2021 Modification Index

Applicable Code: 2021 International Residential Code

Modification Index Number: IRC 2021-55

Code Section: P2603.5 Freezing

Modification:

P2603.5 Freezing. In localities having a winter design temperature of 32°F (0°C) or lower as shown in Table R301.2 of this code, a water pipe shall not be installed outside of a building, in exterior walls, in *attics* or crawl spaces, or in any other place subjected to freezing temperature unless adequate provision is made to protect it from freezing by insulation or heat or both. Water service pipe shall be installed not less than 12 inches (305 mm) deep and not less than 6 inches (152 mm) below the frost line.

Exception: Water pipes that are installed on the warm in winter side of the building envelope, i.e. above the insulation line in a floor system or below the insulation line in an attic, do not need additional pipe insulation.

*Modification adds to modified language in IRC 2021-54.

Proponent: Home Builders Association of South Carolina

Previous Code Cycles	Previous Modification Index Number	Previous Code Section
n/a		



South Carolina Department of Labor, Licensing and Regulation
South Carolina Building Codes Council
2021 Modification Index

Applicable Code: 2021 International Residential Code

Modification Index Number: IRC 2021-56

Code Section: P2705.1(3) General

Modification:

P2705.1 General. The installation of fixtures shall conform to the following:

1. Floor-outlet or floor-mounted fixtures shall be secured to the drainage connection and to the floor, where so designed, by screws, bolts, washers, nuts and similar fasteners of copper, copper alloy or other corrosion-resistant material.
2. Wall-hung fixtures shall be rigidly supported so that strain is not transmitted to the plumbing system.
3. Where fixtures come in contact with walls and floors, the contact area shall be watertight.

Exception: Water closets and/or bidets shall not be required to be caulked to flooring surface.

4. Plumbing fixtures shall be usable.
5. Water closets, lavatories and bidets. A water closet, lavatory or bidet shall not be set closer than 15 inches (381 mm) from its center to any side wall, partition or vanity or closer than ~~30 inches (762 mm)~~ 27 inches center-to-center between adjacent fixtures. There shall be a clearance of not less than 21 inches (533 mm) in front of a water closet, lavatory or bidet to any wall, fixture or door.
6. The location of piping, fixtures or equipment shall not interfere with the operation of windows or doors.
7. In flood hazard areas as established by Table R301.2, plumbing fixtures shall be located or installed in accordance with Section R322.1.6.
8. Integral fixture-fitting mounting surfaces on manufactured plumbing fixtures or plumbing fixtures constructed on site, shall meet the design requirements of ASME A112.19.2/CSA B45.1 or ASME A112.19.3/CSA B45.4.

*Modification includes the approved portion of IRC 2021-14 in (5).

Proponent: Home Builders Association of South Carolina

Previous Code Cycles	Previous Modification Index Number	Previous Code Section
N/A		



South Carolina Department of Labor, Licensing and Regulation
South Carolina Building Codes Council
2021 Modification Index

Applicable Code: 2021 International Residential Code

Modification Index Number: IRC 2021-57

Code Section: P2708.4 Shower control valves

Modification:

P2708.4 Shower control valves. Individual shower and tub/shower combination valves shall be balanced-pressure, thermostatic or combination balanced-pressure/thermostatic valves that conform to the requirements of ASSE 1016/ASME 112.1016/CSA B125.16 or ASME A112.18.1/CSA B125.1. ~~Shower control valves shall be rated for the flow rate of the installed shower head. Such valves shall be installed at the point of use.~~ Shower and tub/shower combination valves required by this section shall be equipped with a means to limit the maximum setting of the valve to 120°F (49°C), which shall be field adjusted in accordance with the manufacturer's instructions to provide water at a temperature not to exceed 120°F (49° C). In-line thermostatic valves shall not be utilized for compliance with this section.

Proponent: Home Builders Association of South Carolina

Previous Code Cycles	Previous Modification Index Number	Previous Code Section
N/A		



South Carolina Department of Labor, Licensing and Regulation
South Carolina Building Codes Council
2021 Modification Index

Applicable Code: 2021 International Residential Code

Modification Index Number: IRC 2021-58

Code Section: P2713.3 Bathtub and whirlpool bathtub valves

Modification:

P2713.3 Bathtub and whirlpool bathtub valves. Bathtubs and whirlpool bathtub valves shall have or be supplied by a water-temperature-limiting device that conforms to ASSE 1070/ASME A112.1070/CSA B125.70, except where such valves are combination tub/shower valves in accordance with Section P2708.4. The water-temperature-limiting device required by this section shall be equipped with a means to limit the maximum setting of the device to 120°F (49°C), and, where adjustable, shall be field-adjusted in accordance with the manufacturer's instructions to provide hot water at a temperature not to exceed 120°F (49°C). Access shall be provided to water-temperature-limiting devices that conform to ASSE 1070/ASME A112.1070/CSA B125.70.

Exception: Access is not required for nonadjustable water-temperature-limiting devices that conform to ASSE 1070/ASME A112.1070/CSA B125.70 and are integral with a fixture fitting, provided that the fixture fitting itself can be accessed for replacement.

Hot water supplied to bathtubs and whirlpool bathtubs shall be limited to a temperature of not greater than 120°F (49°C) by a water-temperature limiting device that conforms to ASSE 1070/ASME A112.1070/CSA B125.70 or CSA B125.3, except where such protection is otherwise provided by a combination tub/shower valve in accordance with Section P2708.4.

Proponent: Home Builders Association of South Carolina

Previous Code Cycles	Previous Modification Index Number	Previous Code Section
N/A		



South Carolina Department of Labor, Licensing and Regulation
South Carolina Building Codes Council
2021 Modification Index

Applicable Code: 2021 International Residential Code

Modification Index Number: IRC 2021-60

Code Section: P2903.10 Hose bib

Modification:

P2903.10 Hose bib. Hose bibbs subject to freezing, including the “frostproof” type, shall be equipped with an accessible stop-and-waste-type valve inside the building so that they can be controlled and drained during cold periods.
Exception: Frostproof hose bibbs installed such that the stem extends through the building insulation into an open heated or *semiconditioned space* need not be separately valved (see Figure P2903.10).

Section deleted without substitution.

Proponent: Home Builders Association of South Carolina

Previous Code Cycles	Previous Modification Index Number	Previous Code Section
IRC 2018	IRC 2018 40	P2903.10
IRC 2015	IRC 2015 33	P2903.10



South Carolina Department of Labor, Licensing and Regulation
South Carolina Building Codes Council
2021 Modification Index

Applicable Code: 2021 International Residential Code

Modification Index Number: IRC 2021-62

Code Section: P2904.2.4.2.1 Additional requirements for pendant sprinklers

Modification:

P2904.2.4.2.1 Additional requirements for pendent sprinklers. Pendent sprinklers within 3 feet (915 mm) of the center of a ceiling fan, surface mounted ceiling luminaire or similar object shall be considered to be obstructed, and additional sprinklers shall be installed.

Exception: Pendant sprinklers within 3 feet (915 mm) of the center of a ceiling fan shall not be considered to be obstructed if the total area of the fan blades do not exceed more than 50 percent of the plan area view.

Proponent: South Carolina Master Plumbers Association

Previous Code Cycles	Previous Modification Index Number	Previous Code Section
N/A		



South Carolina Department of Labor, Licensing and Regulation
South Carolina Building Codes Council
2021 Modification Index

Applicable Code: 2021 International Residential Code

Modification Index Number: IRC 2021-66

Code Section: E3606.5 Surge protection

Modification:

~~**E3606.5 Surge protection.** All services supplying one- and two-family dwelling units shall be provided with a surgeprotective device (SPD) installed in accordance with Sections E3606.5.1 through E3606.5.3.~~

~~**E3606.5.1 Location.** The SPD shall be an integral part of the service equipment or shall be located immediately adjacent thereto.~~

~~**Exception:** The SPD shall not be required to be located in the service equipment if located at each next-level distribution equipment downstream toward the load.~~

~~**E3606.5.2 Type.** The SPD shall be a Type 1 or Type 2 SPD.~~

~~**E3606.5.3 Replacement.** Where service equipment is replaced, all of the requirements of this section shall apply. [230.67]~~

Proponent: Home Builders Association of South Carolina

Previous Code Cycles	Previous Modification Index Number	Previous Code Section
N/A		



South Carolina Department of Labor, Licensing and Regulation
South Carolina Building Codes Council
2021 Modification Index

Applicable Code: 2021 International Residential Code

Modification Index Number: IRC 2021-67

Code Section: E3802.4 In unfinished basements

Modification:

E3802.4 In unfinished basements and crawl spaces. Where Type NM or SE cable is run at angles with joists in unfinished basements and crawl spaces, cable assemblies containing two or more conductors of sizes 6 AWG and larger and assemblies containing three or more conductors of sizes 8 AWG and larger shall not require additional protection where attached directly to the bottom of the joists. Smaller cables shall be run either through bored holes in joists or on running boards. Type NM or SE cable installed on the wall of an unfinished basement shall be permitted to be installed in a *listed* conduit or tubing or shall be protected in accordance with Table E3802.1. Conduit or tubing shall be provided with a suitable insulating bushing or adapter at the point where the cable enters the raceway. The sheath of the Type NM or SE cable shall extend through the conduit or tubing and into the outlet or device box not less than 1/4 inch (6.4 mm). The cable shall be secured within 12 inches (305 mm) of the point where the cable enters the conduit or tubing. Metal conduit, tubing, and metal outlet boxes shall be connected to an equipment grounding conductor complying with Section E3908.14. [334.15(C)]

Proponent: Home Builders Association of South Carolina

Previous Code Cycles	Previous Modification Index Number	Previous Code Section
IRC 2018	IRC 2018 42	E3802.4
IRC 2015	IRC 2015 35	E3802.4



South Carolina Department of Labor, Licensing and Regulation
South Carolina Building Codes Council
2021 Modification Index

Applicable Code: 2021 International Residential Code

Modification Index Number: IRC 2021-69

Code Section: E3901.4.2 (1) Island and peninsular countertops and work spaces

Modification:

E3901.4.2 Island and peninsular countertops and work spaces. Receptacle outlets shall be installed in accordance with the following: [210.52(C)(2)]

1. At least one receptacle outlet shall be provided for the first 9-square feet 6 feet of length (0.84 m²), or fraction thereof, of the countertop or work surface. ~~A receptacle outlet shall be provided for every additional 18 square feet (1.7 m²), or fraction thereof, of the countertop or work surface.~~ [210.52(C)(2)(a)] A minimum of two receptacle outlets shall be provided for any island over 6 feet long.
2. At least one receptacle outlet shall be located within 2 feet (600 mm) of the outer end of a peninsular countertop or work surface. Additional receptacle outlets shall be permitted to be located as determined by the installer, designer or building owner. The location of the receptacle outlets shall be in accordance with Section E3901.4.3. [210.52(C)(2)(b)]

Proponent: Home Builders Association of South Carolina

Previous Code Cycles	Previous Modification Index Number	Previous Code Section
N/A		



South Carolina Department of Labor, Licensing and Regulation
South Carolina Building Codes Council
2021 Modification Index

Applicable Code: 2021 International Residential Code

Modification Index Number: IRC 2021-70

Code Section: E3902 Ground-Fault and Arc-Fault Circuit-Interrupter Protection

Modification:

SECTION E3902
GROUND-FAULT AND ARC-FAULT
CIRCUIT-INTERRUPTER PROTECTION

Entire section E3902.1 - E3902.18 modified to remove “through 250 volt” from text.

Proponent: Home Builders Association of South Carolina

Previous Code Cycles	Previous Modification Index Number	Previous Code Section
N/A		



South Carolina Department of Labor, Licensing and Regulation
South Carolina Building Codes Council
2021 Modification Index

Applicable Code: 2021 International Residential Code

Modification Index Number: IRC 2021-71

Code Section: E3902.5 Basement receptacles

Modification:

E3902.5 Basement receptacles. 125-volt receptacles installed in basements and supplied by single phase branch circuits rated 150 volts or less to ground shall have ground-fault circuit-interrupter protection for personnel. [210.8(A)(5)]

Exceptions:

1. A receptacle supplying only a permanently installed fire alarm or burglar alarm system. A receptacle installed in accordance with this exception shall not be considered as meeting the requirement of Section E3901.9. Receptacles installed in accordance with this exception shall not be considered as meeting the requirement of Section E3901.9. [210.8(A)(5) Exception]

2. Receptacles in walk-out basements are excluded from this requirement.

Proponent: Home Builders Association of South Carolina

Previous Code Cycles	Previous Modification Index Number	Previous Code Section
N/A		



South Carolina Department of Labor, Licensing and Regulation
South Carolina Building Codes Council
2021 Modification Index

Applicable Code: 2021 International Residential Code

Modification Index Number: IRC 2021-73

Code Section: E3902.17 Arc-fault circuit interrupter protection

Modification:

E3902.17 Arc-fault circuit interrupter protection. ~~In areas other than kitchen and laundry areas, B~~branch circuits that supply 120-volt, single-phase, 15- and 20- ampere outlets installed in ~~kitchens~~, family rooms, dining rooms, living rooms, parlors, libraries, dens, bedrooms, *sunrooms*, recreations rooms, closets, hallways, ~~laundry areas~~ and similar rooms or areas shall be protected by any of the following: [210.12(A)]

(language in 1 - 6 unchanged)

Proponent: Home Builders Association of South Carolina

Previous Code Cycles	Previous Modification Index Number	Previous Code Section
IRC 2018	IRC 2018 44	3902.16



South Carolina Department of Labor, Licensing and Regulation
South Carolina Building Codes Council
2021 Modification Index

Applicable Code: 2021 International Residential Code

Modification Index Number: IRC 2021-75

Code Section: E4002.14 Tamper-resistant receptacles

Modification:

E4002.14 Tamper-resistant receptacles. In areas specified in Section E3901.1, 15- and 20-ampere, 125- and 250-volt nonlocking-type receptacles shall be *listed* tamper-resistant receptacles. [406.12]

Proponent: Home Builders Association of South Carolina

Previous Code Cycles	Previous Modification Index Number	Previous Code Section
N/A		



South Carolina Department of Labor, Licensing and Regulation
South Carolina Building Codes Council
2021 Modification Index

Applicable Code: 2021 International Residential Code

Modification Index Number: IRC 2021-76

Code Section: Chapter 44 Referenced Standards

Modification:

<p>ANCE</p> <p>NMX-J-521/2-40-ANCE --2014/CAN/CSA-22.2 No. 60335-2-40 --12/UL-60335-2-40: Safety of Household and Similar Electric Appliances, Part 2-40: Particular Requirements for Heat Pumps, Air-Conditioners and Dehumidifiers</p> <p>M1403.1, M1412.1, M1413.1</p>	<p style="text-align: right;">Association of Standardization and Certification</p> <p style="text-align: right;">Av. Lázaro Cárdenas No. 869</p> <p style="text-align: right;">Fraccion 3</p> <p style="text-align: right;">Col. Nva. Industrial Vallejo</p> <p style="text-align: right;">Deleg. Gustavo A. Madero</p> <p style="text-align: right;">Mexico, D.F.</p>
<p>CSA</p> <p>CAN/CSA/C22.2 No. 60335-2-40 --2012 2019:</p> <p>M1402.1, M1403.1, M1412.1, M1413.1, M2006.1</p>	<p style="text-align: right;">CSA Group</p> <p style="text-align: right;">8501 East Pleasant Valley Road</p> <p style="text-align: right;">Cleveland, OH 44131-5516</p> <p style="text-align: right;">Safety of Household and Similar Electrical Appliances, Part 2-40: Particular Requirements for Electrical Heat Pumps, Air-Conditioners and Dehumidifiers <u>3rd edition</u></p>
<p>UL</p> <p>UL/CSA/ANCE 60335-2-40 --2012 2019: Standard for Household and Similar Electrical Appliances, Part 2-40: Particular Requirements for Motor-compressors Electrical Heat Pumps, Air-Conditioners and Dehumidifiers</p> <p>M1402.1, M1403.1, M1412.1, M1413.1, M2006.1</p>	<p style="text-align: right;">UL LLC</p> <p style="text-align: right;">333 Pfinstgen Road</p> <p style="text-align: right;">Northbrook, IL 60062</p>

Proponent: Air-Conditioning, Heating and Refrigeration Institute (AHRI)

Previous Code Cycles	Previous Modification Index Number	Previous Code Section
N/A		



South Carolina Department of Labor, Licensing and Regulation
South Carolina Building Codes Council
2021 Modification Index

Applicable Code: 2021 International Residential Code

Modification Index Number: IRC 2021-77

Code Section: Appendix AH Patio Covers

Modification:

APPENDIX AH
PATIO COVERS

Appendix adopted for use statewide.

Proponent: Structural Engineers Association of South Carolina

Previous Code Cycles	Previous Modification Index Number	Previous Code Section
IRC 2018	IRC 2018 45	Appendix H
IRC 2015	IRC 2015 36	Appendix H
IRC 2012	IRC 2012 25	Appendix H



South Carolina Department of Labor, Licensing and Regulation
South Carolina Building Codes Council
2021 Modification Index

Applicable Code: 2021 International Residential Code

Modification Index Number: IRC 2021-78

Code Section: Appendix AJ Existing Buildings and Structures

Modification:

APPENDIX AJ
EXISTING BUILDINGS AND STRUCTURES

Appendix adopted for use statewide.

Proponent: Structural Engineers Association of South Carolina

Previous Code Cycles	Previous Modification Index Number	Previous Code Section
IRC 2018	IRC 2018 46	Appendix J
IRC 2015	IRC 2015 37	Appendix J



South Carolina Department of Labor, Licensing and Regulation
South Carolina Building Codes Council
2021 Modification Index

Applicable Code: 2021 International Residential Code

Modification Index Number: IRC 2021-79

Code Section: Appendix AQ Tiny Houses

Modification:

**APPENDIX AQ
TINY HOUSES**

Appendix adopted for use statewide.

Proponent: BOASC

Previous Code Cycles	Previous Modification Index Number	Previous Code Section
IRC 2018	IRC 2018 47	Appendix Q



South Carolina Department of Labor, Licensing and Regulation
South Carolina Building Codes Council
2021 Modification Index

Applicable Code: 2021 International Fire Code

Modification Index Number: IFC 2021-02

Code Section: 202 General definitions

Modification:

Primitive Camp Structure: Shall include any structure permanent or temporary in nature, used for outdoor camping (transient), open on at least one side with no fully enclosed habitable spaces, less than 400 square feet under roof, and not classified as a residential occupancy due to lack of electrical, plumbing, mechanical, and sprinkler systems.

Proponent: BOASC

Previous Code Cycles	Previous Modification Index Number	Previous Code Section
IFC 2018	IFC 2018 02	202



South Carolina Department of Labor, Licensing and Regulation
South Carolina Building Codes Council
2021 Modification Index

Applicable Code: 2021 International Fire Code

Modification Index Number: IFC 2021-03

Code Section: 202 General definitions

Modification:

[BG] Assembly Group A-3. Group A-3 occupancy includes assembly uses intended for worship, recreation or amusement and other assembly uses not classified elsewhere in Group A, including, but not limited to:

- Amusement arcades
- Art galleries
- Bowling alleys
- Community halls
- Courtrooms
- Dance halls (not including food or drink consumption)
- Exhibition halls
- Funeral parlors
- Greenhouses with public access for the conservation and exhibition of plants
- Gymnasiums (without spectator seating)
- Indoor swimming pools (without spectator seating)
- Indoor tennis courts (without spectator seating) Lecture halls
- Libraries
- Museums
- Places of religious worship
- Pool and billiard parlors
- Structures without a commercial kitchen, used in agritourism activity as defined by S.C. Code Ann. 46-53-10(1)
- Waiting areas in transportation terminals

Proponent: BOASC

Previous Code Cycles	Previous Modification Index Number	Previous Code Section
IFC 2018	IFC 2018 03	202



South Carolina Department of Labor, Licensing and Regulation
South Carolina Building Codes Council
2021 Modification Index

Applicable Code: 2021 International Fire Code

Modification Index Number: IFC 2021-04

Code Section: 202 General definitions

Modification:

RECREATIONAL FIRE. An outdoor fire burning materials other than rubbish where the fuel being burned is not contained in an incinerator, outdoor fireplace, portable outdoor fireplace, barbeque grill or barbeque pit and has a total fuel area of 3 feet (914 mm) or less in diameter and 2 feet (610 mm) or less in height for pleasure, religious, ceremonial to include sky lanterns, cooking, warmth or similar purpose.

Proponent: South Carolina Fire Marshal's Association

Previous Code Cycles	Previous Modification Index Number	Previous Code Section
IFC 2018	IFC 2018 01	202
IFC 2015	IFC 2015 01	202
IFC 2012	IFC 2012 01	202



South Carolina Department of Labor, Licensing and Regulation
South Carolina Building Codes Council
2021 Modification Index

Applicable Code: 2021 International Fire Code

Modification Index Number: IFC 2021-05

Code Section: 315.3.3 Equipment rooms

Modification:

315.3.3 Equipment rooms. Combustible Material shall not be stored in boiler rooms, mechanical rooms, electrical equipment rooms or in *fire command centers* as specified in Section 508.1.5. Rooms shall be labeled with approved signage “No storage allowed”.

Proponent: Midlands Fire Marshal's Association

Previous Code Cycles	Previous Modification Index Number	Previous Code Section
N/A		



South Carolina Department of Labor, Licensing and Regulation
South Carolina Building Codes Council
2021 Modification Index

Applicable Code: 2021 International Fire Code

Modification Index Number: IFC 2021-07

Code Section: 319.11 Clearance requirements

Modification:

319.11 Mobile cooking operations. Shall be separated from buildings, structures, canopies, tents, combustible materials, vehicles, and other cooking operations by a minimum of 10 feet. Exhaust shall be directed away from openings, air intakes and away from any means of egress.

Proponent: Midlands Fire Marshal's Association

Previous Code Cycles	Previous Modification Index Number	Previous Code Section
N/A		



South Carolina Department of Labor, Licensing and Regulation
South Carolina Building Codes Council
2021 Modification Index

Applicable Code: 2021 International Fire Code

Modification Index Number: IFC 2021-08

Code Section: 503.1.2 Additional access

Modification:

503.1.2 Additional access. The *fire code official* is authorized to require more than one fire apparatus access road based on the potential for impairment of a single road by vehicle congestion, condition of terrain, climatic conditions or other factors that could limit access.

Exception. Where two fire apparatus access roads are required by Section 503.1.2 or this appendix, the additional fire apparatus access road is permitted to be a driveway, pathway, court or other approved *fire lane* not accessible to public motor vehicles where designed by a registered design professional to meet the loading requirements and minimum specifications of Section 503 and this appendix, and the surface provides all-weather driving capabilities. Marking or signs shall be provided in accordance with Section 503.3 and Section D103.6

Proponent: Home Builders Association of South Carolina

Previous Code Cycles	Previous Modification Index Number	Previous Code Section
N/A		



South Carolina Department of Labor, Licensing and Regulation
South Carolina Building Codes Council
2021 Modification Index

Applicable Code: 2021 International Fire Code

Modification Index Number: IFC 2021-09

Code Section: 503.1.2.1

Modification:

503.1.2.1 One- or two-family dwelling residential developments having less than 50 units. Developments of one- or two-family dwellings where the number of dwelling units does not exceed 50 shall be permitted to have a single approved fire apparatus access road provided all of the following requirements are met.

1. The minimum unobstructed width of the single fire apparatus access road shall be 26 feet (7925 mm) and shall otherwise comply with Section 503.
2. A minimum of one fire hydrant on each side of the fire apparatus access road in accordance with Section 507.5 shall be provided. The fire code official shall be permitted to require additional hydrants and hydrant spacing based on the length of the fire apparatus access road, fire flow requirements, and the distance from any point on the street or road frontage to a hydrant.
3. The development is not located in a wildland-urban interface area as defined in the International Wildland-Urban Interface Code.

Future Development. The number of dwelling units on a single fire apparatus access road shall not be increased unless fire apparatus access roads will connect with future development, as determined by the fire code official.

Proponent: Home Builders Association of South Carolina

Previous Code Cycles	Previous Modification Index Number	Previous Code Section
N/A		



South Carolina Department of Labor, Licensing and Regulation
South Carolina Building Codes Council
2021 Modification Index

Applicable Code: 2021 International Fire Code

Modification Index Number: IFC 2021-10

Code Section: 503.2.1 Dimensions

Modification:

503.2.1 Dimensions. Fire apparatus access roads shall have an unobstructed width of not less than 20 feet (6096 mm), exclusive of shoulders, except for approved security gates in accordance with Section 503.6 and an unobstructed vertical clearance of not less than 13 feet 6 inches (4115 mm).

Proponent: Home Builders Association of South Carolina

Previous Code Cycles	Previous Modification Index Number	Previous Code Section
IFC 2018	IFC 2018 05	503.2.1
IFC 2015	IFC 2015 04	503.2.1
IFC 2012	IFC 2012 04	503.2.1



South Carolina Department of Labor, Licensing and Regulation
South Carolina Building Codes Council
2021 Modification Index

Applicable Code: 2021 International Fire Code

Modification Index Number: IFC 2021-11

Code Section: 507.1 Required water supply

Modification:

507.1 Required water supply. An approved water supply capable of supplying the required fire flow for fire protection shall be provided to premises on which facilities, buildings or portions of buildings are hereafter constructed or moved into or within the jurisdiction to meet the necessary fire flow as determined by the fire code official. Where public water supply is inadequate or not available, an approved alternative water source meeting the fire flow requirements shall be provided. Fire flow performance tests shall be witnessed by the fire official or representative prior to final approval.

Exception. One- and two-family dwellings, including attached or detached accessory structures.

Proponent: Charleston Fire Department

Previous Code Cycles	Previous Modification Index Number	Previous Code Section
IFC 2018	IFC 2018 06	507.1



South Carolina Department of Labor, Licensing and Regulation
South Carolina Building Codes Council
2021 Modification Index

Applicable Code: 2021 International Fire Code

Modification Index Number: IFC 2021-12

Code Section: 507.5.1 Where Required

Modification:

507.5.1 Where required. Where a portion of the facility or building hereafter constructed or moved into or within the jurisdiction is more than ~~400 feet (122 m)~~ 500 feet (152m) from a hydrant on a fire apparatus access road, as measured by an approved route around the exterior of the facility or building, on-site fire hydrants and mains shall be provided where required by the fire code official.

Location. The location and number of hydrants shall be designated by the fire official, but in no case shall the distance between installed fire hydrants exceed 1000 feet (305m). Fire hydrants shall be located within 500 feet (152m) of all fire fighter access points when measured along the normal routes of fire department vehicle access which conforms to the requirements of Section 503. No point of the exterior of a building shall be located more than 500 feet (152m) from a hydrant accessible to fire department vehicles as provided in Section 503.

Exceptions:

1. For Group R-3 and Group U occupancies, the distance requirement shall be 600 feet (183 m).
2. For buildings equipped throughout with an approved automatic sprinkler system installed in accordance with Section 903.3.1.1 or 903.3.1.2, the distance requirement shall be 600 feet (183 m).

Proponent: Charleston Fire Department

Previous Code Cycles	Previous Modification Index Number	Previous Code Section
IFC 2018	IFC 2018 07	507.5.1



South Carolina Department of Labor, Licensing and Regulation
South Carolina Building Codes Council
2021 Modification Index

Applicable Code: 2021 International Fire Code

Modification Index Number: IFC 2021-13

Code Section: 507.5.1.1 Hydrant for standpipe systems

Modification:

507.5.1.1 Hydrant for standpipe systems. Buildings equipped with a standpipe or fire sprinkler system installed in accordance with Section 903 or 905 shall have a fire hydrant within 100 feet (30 480 mm) of the fire department connections.

Exception: The distance shall be permitted to exceed 100 feet (30 480 mm) where *approved* by the *fire code official*.

Proponent: Midlands Fire Marshal's Association

Previous Code Cycles	Previous Modification Index Number	Previous Code Section
N/A		



South Carolina Department of Labor, Licensing and Regulation
South Carolina Building Codes Council
2021 Modification Index

Applicable Code: 2021 International Fire Code

Modification Index Number: IFC 2021-14

Code Section: 507.5.4 Obstruction

Modification:

507.5.4 Obstruction. Unobstructed access to fire hydrants shall be maintained at all times. The fire department shall not be deterred or hindered from gaining immediate access to fire protection equipment or fire hydrants. No parking shall be allowed within 15 feet of a fire hydrant.

Proponent: Midlands Fire Marshal's Association

Previous Code Cycles	Previous Modification Index Number	Previous Code Section
N/A		



South Carolina Department of Labor, Licensing and Regulation
South Carolina Building Codes Council
2021 Modification Index

Applicable Code: 2021 International Fire Code

Modification Index Number: IFC 2021-16

Code Section: 607.1 General

Modification:

607.1 General. Storage of cooking oil (grease) in commercial cooking operations utilizing above-ground tanks with a capacity greater than 60 gal (227 L) installed within a building shall comply with Sections 607.2 through 607.7 and NFPA 30. For purposes of this section, cooking oil shall be classified as a Class IIIB liquid unless otherwise determined by testing. These tanks shall have the contents identified as outlined in Section 5703.5.

Proponent: Midlands Fire Marshal's Association

Previous Code Cycles	Previous Modification Index Number	Previous Code Section
N/A		



South Carolina Department of Labor, Licensing and Regulation
South Carolina Building Codes Council
2021 Modification Index

Applicable Code: 2021 International Fire Code

Modification Index Number: IFC 2021-19

Code Section: 901.6.3 Records

Modification:

901.6.3 Records. Records of all system inspections, tests and maintenance required by the referenced standards shall be maintained. Copies of the inspection reports shall be sent to the local jurisdiction by the servicing vendor as prescribed by the fire code official.

Proponent: Charleston Fire Department

Previous Code Cycles	Previous Modification Index Number	Previous Code Section
IFC 2018	IFC 2018 08	901.6.3



South Carolina Department of Labor, Licensing and Regulation
South Carolina Building Codes Council
2021 Modification Index

Applicable Code: 2021 International Fire Code

Modification Index Number: IFC 2021-22

Code Section: 907.6.5 Access

Modification:

907.6.5 Access. Access shall be provided to each fire alarm device and notification appliance for periodic inspection, maintenance and testing. Fire alarm notification devices shall be unobstructed and visible at all times.

Proponent: Midlands Fire Marshal's Association

Previous Code Cycles	Previous Modification Index Number	Previous Code Section
N/A		



South Carolina Department of Labor, Licensing and Regulation
South Carolina Building Codes Council
2021 Modification Index

Applicable Code: 2021 International Fire Code

Modification Index Number: IFC 2021-24

Code Section: 1010.2.14 Controlled egress doors in Groups I-1 and I-2

Modification:

[BE] 1010.2.14 Controlled egress doors in Groups I-1, I-2 and I-4 (Adult Day Care occupancy only). Electric locking systems, including electromechanical locking systems and electromagnetic locking systems, shall be permitted to be locked in the means of egress in Group I-1, I-2 and I-4 (Adult Day Care occupancy only) occupancies where the clinical needs of persons receiving care require their containment. Controlled egress doors shall be permitted in such occupancies where the building is equipped throughout with an *automatic sprinkler system* in accordance with Section 903.3.1.1 or an *approved* automatic smoke detection system installed in accordance with Section 907, provided that the doors are installed and operate in accordance with all of the following:

1. The door locks shall unlock on actuation of the automatic sprinkler system or automatic smoke detection system.
2. The door locks shall unlock on loss of power controlling the lock or lock mechanism.
3. The door locking system shall be installed to have the capability of being unlocked by a switch located at the fire command center, a nursing station or other approved location. The switch shall directly break power to the lock.
4. A building occupant shall not be required to pass through more than one door equipped with a controlled egress locking system before entering an exit.
5. The procedures for unlocking the doors shall be described and approved as part of the emergency planning and preparedness required by Chapter 4 of the International Fire Code.
6. All clinical staff shall have the keys, codes or other means necessary to operate the locking systems.
7. Emergency lighting shall be provided at the door.
8. The door locking system units shall be listed in accordance with UL 294.

Exceptions:

1. Items 1 through 4 shall not apply to doors to areas occupied by persons who, because of clinical needs, require restraint or containment as part of the function of a psychiatric or cognitive treatment area.
2. Items 1 through 4 shall not apply to doors to areas where a listed egress control system is utilized to reduce the risk of child abduction from nursery and obstetric areas of a Group I-2 hospital.

Proponent: Midlands Fire Marshal's Association

Previous Code Cycles	Previous Modification Index Number	Previous Code Section
N/A		



South Carolina Department of Labor, Licensing and Regulation
South Carolina Building Codes Council
2021 Modification Index

Applicable Code: 2021 International Fire Code

Modification Index Number: IFC 2021-25

Code Section: 1016.2 Egress through intervening spaces

Modification:

1016.2 Egress through intervening spaces. Egress through intervening spaces shall comply with this section.

1. Exit access through an enclosed elevator lobby is permitted. Where access to two or more exits or exit access doorways is required in Section 1006.2.1, access to not less than one of the required exits shall be provided without travel through the enclosed elevator lobbies required by Section 3006 of the South Carolina Building Code. Where the path of exit access travel passes through an enclosed elevator lobby, the level of protection required for the enclosed elevator lobby is not required to be extended to the exit unless direct access to an exit is required by other sections of this code.
2. Egress from a room or space shall not pass through adjoining or intervening rooms or areas, except where such adjoining rooms or areas and the area served are accessory to one or the other, are not a Group H occupancy and provide a discernible path of egress travel to an exit.

Exception: Means of egress are not prohibited through adjoining or intervening rooms or spaces in a Group H, S or F occupancy where the adjoining or intervening rooms or spaces are the same or a lesser hazard occupancy group.
3. An exit access shall not pass through a room that can be locked to prevent egress.
4. Means of egress from dwelling units or sleeping areas shall not lead through other sleeping areas, toilet rooms or bathrooms.

Exception: Dwelling units or sleeping areas in R-1 and R-2 occupancies shall be permitted to egress through other sleeping areas serving adjoining rooms that are part of the same dwelling unit or guest room.
5. Egress shall not pass through kitchens, storage rooms, closets or spaces used for similar purposes.

Exceptions:
 1. Means of egress are not prohibited through a kitchen area serving adjoining rooms constituting part of the same dwelling unit or sleeping unit.
 2. Means of egress are not prohibited through stockrooms in Group M occupancies where all of the following are met:
 - 2.1. The stock is of the same hazard classification as that found in the main retail area.
 - 2.2. Not more than 50 percent of the exit access is through the stockroom.
 - 2.3. The stockroom is not subject to locking from the egress side.
 - 2.4. There is a demarcated, minimum 44-inch-wide (1118 mm) aisle defined by ~~full- or partial-height fixed walls~~ a wall not less than 42 inches high or similar construction that will maintain the required width and lead directly from the retail area to the exit without obstructions.

Proponent: Charleston Fire Department

Previous Code Cycles	Previous Modification Index Number	Previous Code Section
IFC 2018	IFC 2018 11	1016.2



South Carolina Department of Labor, Licensing and Regulation
South Carolina Building Codes Council
2021 Modification Index

Applicable Code: 2021 International Fire Code

Modification Index Number: IFC 2021-31

Code Section: 2303.2.2 Testing

Modification:

2303.2.2 Testing. Emergency disconnect switches shall be tested annually by the responsible party to ensure proper operation; records of testing shall be maintained on site for inspection. Any switches determined to be faulty, the fuel pumps they serve shall be taken out of service until the emergency shutoff switch is placed back into service.

Proponent: Midlands Fire Marshal's Association

Previous Code Cycles	Previous Modification Index Number	Previous Code Section
N/A		



South Carolina Department of Labor, Licensing and Regulation
South Carolina Building Codes Council
2021 Modification Index

Applicable Code: 2021 International Fire Code

Modification Index Number: IFC 2021-33

Code Section: 2305.5 Fire extinguishers

Modification:

2305.5 Fire extinguishers. *Approved* portable fire extinguishers complying with Section 906 with a minimum rating of 2-A:20-B:C shall be provided and located such that an extinguisher is not more than ~~75 feet (22 860 mm)~~ 50 feet (15 240 mm) from pumps, dispensers or storage tank fill-pipe openings.

Proponent: Midlands Fire Marshal's Association

Previous Code Cycles	Previous Modification Index Number	Previous Code Section
N/A		



South Carolina Department of Labor, Licensing and Regulation
South Carolina Building Codes Council
2021 Modification Index

Applicable Code: 2021 International Fire Code

Modification Index Number: IFC 2021-34

Code Section: 2307.4 Location of dispensing operations and equipment

Modification:

2307.4 Location of dispensing operations and equipment. The point of transfer for LP-gas dispensing operations shall be separated from buildings and other exposures in accordance with NFPA 58 Table 6.7.2.1 and IFC Section 2306.7, the following:

1. Not less than 25 feet (7620 mm) from buildings where the exterior wall is not part of a fire-resistance-rated assembly having a rating of 1 hour or greater.
2. Not less than 25 feet (7620 mm) from combustible overhangs on buildings, measured from a vertical line dropped from the face of the overhang at a point nearest the point of transfer.
3. Not less than 25 feet (7620 mm) from the lot line of property that can be built on.
4. Not less than 25 feet (7620 mm) from the centerline of the nearest mainline railroad track.
5. Not less than 10 feet (3048 mm) from public streets, highways, thoroughfares, sidewalks and driveways.
6. Not less than 10 feet (3048 mm) from buildings where the exterior wall is part of a fire-resistance-rated assembly having a rating of 1 hour or greater.

Exception: The point of transfer for LP-gas dispensing operations need not be separated from canopies that are constructed in accordance with the International Building Code and that provide weather protection for the dispensing equipment.

LP-Gas containers shall be located in accordance with Chapter 61. LP-gas storage and dispensing equipment shall be located outdoors and in accordance with Section 2306.7.

Proponent: South Carolina Propane Gas Association

Previous Code Cycles	Previous Modification Index Number	Previous Code Section
IFC 2018	IFC 2018 12	2307.4
IFC 2015	IFC 2015 09	2307.4
IFC 2012	IFC 2012 09	2307.4



South Carolina Department of Labor, Licensing and Regulation
South Carolina Building Codes Council
2021 Modification Index

Applicable Code: 2021 International Fire Code

Modification Index Number: IFC 2021-35

Code Section: 2307.7 Public fueling of motor vehicles

Modification:

2307.7 Public fueling of motor vehicles. Self-service LP-gas dispensing systems, including key, code and card lock dispensing systems, shall be limited to the filling of permanently mounted containers providing fuel to the LP-gas powered vehicle.

The requirements for self-service LP-gas dispensing systems shall be in accordance with the following:

1. The arrangement and operation of the transfer of product into a vehicle shall be in accordance with this section and Chapter 61.
2. The system shall be provided with an emergency shutoff switch located within 100 feet (30 480 mm) of, but not less than 20 feet (6096 mm) from, dispensers.
3. The owner of the LP-gas motor fuel-dispensing facility or the owner's designee shall provide for the safe operation of the system and the training of users.
4. The dispenser and hose-end valve shall release not more than 1/8 fluid ounce (4 cc) of liquid to the atmosphere upon breaking the connection with the fill valve on the vehicle.
5. Portable fire extinguishers shall be provided in accordance with Section 2305.5.
6. Warning signs shall be provided in accordance with Section 2305.6.
7. The area around the dispenser shall be maintained in accordance with Section 2305.7.

Proponent: South Carolina Propane Gas Association

Previous Code Cycles	Previous Modification Index Number	Previous Code Section
IFC 2018	IFC 2018 13	2307.7
IFC 2015	IFC 2015 11	2307.7
IFC 2012	IFC 2012 11	2307.6



South Carolina Department of Labor, Licensing and Regulation
South Carolina Building Codes Council
2021 Modification Index

Applicable Code: 2021 International Fire Code

Modification Index Number: IFC 2021-38

Code Section: 6101.1 Scope

Modification:

6101.1 Scope. Storage, handling and transportation of liquefied petroleum gas (LP-gas) and the installation of LP-gas equipment pertinent to systems for such uses shall comply with this chapter and NFPA 58. Properties of LP-gases shall be determined in accordance with ~~Appendix~~ Annex B of NFPA 58.

Proponent: South Carolina Fire Marshal's Association

Previous Code Cycles	Previous Modification Index Number	Previous Code Section
IFC 2018	IFC 2018 14	6101.1
IFC 2015	IFC 2015 12	6101.1
IFC 2012	IFC 2012 12	6101.1



South Carolina Department of Labor, Licensing and Regulation
South Carolina Building Codes Council
2021 Modification Index

Applicable Code: 2021 International Fire Code

Modification Index Number: IFC 2021-41

Code Section: 6106.1 Attendants

Modification:

6106.1 Attendants. Dispensing of LP-gas shall be performed by a qualified attendant that meets the requirements of this section and NFPA 58 Section 4.4.

Proponent: South Carolina Fire Marshal's Association

Previous Code Cycles	Previous Modification Index Number	Previous Code Section
IFC 2018	IFC 2018 17	6106.1
IFC 2015	IFC 2015 16	6106.1
IFC 2012	IFC 2012 16	6106.1



South Carolina Department of Labor, Licensing and Regulation
South Carolina Building Codes Council
2021 Modification Index

Applicable Code: 2021 International Fire Code

Modification Index Number: IFC 2021-42

Code Section: 6107.4 Protecting containers from vehicles

Modification:

6107.4 Protecting containers from vehicles. Where exposed to vehicular damage due to proximity to alleys, driveways or parking areas, LP-gas containers, regulators and piping shall be protected in accordance with NFPA 58.

Exception: An alternative method may be used that meets the intent of this section with the approval of the AHJ.

Proponent: South Carolina Fire Marshal's Association

Previous Code Cycles	Previous Modification Index Number	Previous Code Section
IFC 2018	IFC 2018 18	6107.4
IFC 2015	IFC 2015 18	6107.4
IFC 2012	IFC 2012 18	6107.4



South Carolina Department of Labor, Licensing and Regulation
South Carolina Building Codes Council
2021 Modification Index

Applicable Code: 2021 International Fire Code

Modification Index Number: IFC 2021-43

Code Section: 6109.13 Protection of containers

Modification:

6109.13 Protection of containers. LP-gas containers shall be stored within a suitable enclosure or otherwise protected against tampering. Vehicle impact protection shall be provided as required by ~~Section 6107.4.~~ the fire code official in accordance with Section 312 or NFPA 58 8.4.2.2.

Exception: Vehicle impact protection shall not be required for protection of LP-gas containers where the containers are kept in lockable, ventilated cabinets of metal construction.

Proponent: South Carolina Fire Marshal's Association

Previous Code Cycles	Previous Modification Index Number	Previous Code Section
IFC 2018	IFC 2018 20	6109.13
IFC 2015	IFC 2015 22	6109.13
IFC 2012	IFC 2012 22	6109.13



South Carolina Department of Labor, Licensing and Regulation
South Carolina Building Codes Council
2021 Modification Index

Applicable Code: 2021 International Fire Code

Modification Index Number: IFC 2021-44

Code Section: 6110.1 Removed from service

Modification:

6110.1 Removed from service Containers not connected for service at customer locations. LP-gas containers at customers' locations that are not connected for service whose use has been discontinued shall comply with both all of the following:

1. — Be disconnected from appliance piping.
- 2.1. Have LP-gas container outlets, except relief valves, closed and or plugged or capped.
- 3.2. Be positioned with the relief valve in direct communication with the LP-gas container vapor space.

Proponent: SC Fire Marshal's Association

Previous Code Cycles	Previous Modification Index Number	Previous Code Section
IFC 2018	IFC 2018 21	6110.1
IFC 2015	IFC 2015 23	6110.1
IFC 2012	IFC 2012 23	6110.1



South Carolina Department of Labor, Licensing and Regulation
South Carolina Building Codes Council
2021 Modification Index

Applicable Code: 2021 International Fire Code

Modification Index Number: IFC 2021-45

Code Section: 6111.2.1

Modification:

6111.2.1 Near residential, educational and institutional occupancies and other high-risk areas. LP-gas tank vehicles shall not be left unattended at any time on residential streets or within 500 feet (152 m) of a residential area, apartment or hotel complex, educational facility, hospital or care facility. Tank vehicles shall not be left unattended at any other place that would, in the opinion of the *fire code official*, pose an extreme life hazard.

Separation distance requirements may be reduced to not less than 50 feet as approved by the fire code official, based upon a completed fire safety analysis and consideration of special features such as topographical conditions, capacity of the LP-gas vehicle and the capabilities of the local fire department. The Office of the State Fire Marshal will provide an approved fire safety analysis to be utilized for this specific requirement.

Proponent: South Carolina Fire Marshal's Association

Previous Code Cycles	Previous Modification Index Number	Previous Code Section
IFC 2018	IFC 2018 22	6111.2.1
IFC 2015	IFC 2015 24	6111.2.1
IFC 2012	IFC 2012 24	6111.2.1



South Carolina Department of Labor, Licensing and Regulation
South Carolina Building Codes Council
2021 Modification Index

Applicable Code: 2021 International Plumbing Code

Modification Index Number: IPC 2021-01

Code Section: 202 General Definitions

Modification:

DRINKING FOUNTAIN. A plumbing fixture that is connected to the potable water distribution system and the drainage system. The fixture allows the user to obtain a drink directly from a stream of flowing water without the use of any accessories. Such fixtures can be separate from or integral to a bottle filling station.

Proponent: Carolinas AGC

Previous Code Cycles	Previous Modification Index Number	Previous Code Section
N/A		



South Carolina Department of Labor, Licensing and Regulation
South Carolina Building Codes Council
2021 Modification Index

Applicable Code: 2021 International Plumbing Code

Modification Index Number: IPC 2021-02

Code Section: 202 General Definitions

Modification:

BOTTLE FILLING STATION. A type of water dispenser that is connected to the potable water distribution system and the drainage system. The fixture is designed and intended for automatically or manually filling personal use drinking water bottles or containers not less than 10 inches (254 mm) in height and is in compliance with the Americans with Disabilities Act (42 U.S.C. § 12101 et seq.) Such fixtures can be separate from or integral to a drinking fountain and can incorporate a water filter and a cooling system for chilling the drinking water.

Proponent: Carolinas AGC

Previous Code Cycles	Previous Modification Index Number	Previous Code Section
N/A		



South Carolina Department of Labor, Licensing and Regulation
South Carolina Building Codes Council
2021 Modification Index

Applicable Code: 2021 International Plumbing Code

Modification Index Number: IPC 2021-03

Code Section: 202 General Definitions

Modification:

WATER COOLER. A drinking fountain or bottle filling station that incorporates a means of reducing the temperature of the water supplied to it from the potable water distribution system.

Proponent: Carolinas AGC

Previous Code Cycles	Previous Modification Index Number	Previous Code Section
N/A		



South Carolina Department of Labor, Licensing and Regulation
South Carolina Building Codes Council
2021 Modification Index

Applicable Code: 2021 International Plumbing Code

Modification Index Number: IPC 2021-04

Code Section: 202 General Definitions

Modification:

WATER DISPENSER. A plumbing fixture that is automatic or manually controlled by the user for the purpose of dispensing potable drinking water into a receptacle such as a cup, glass or bottle. Such fixture is connected to the potable water distribution system of the premises. This definition includes a freestanding apparatus for the same purpose that is not connected to the potable water distribution system and that is supplied with potable water from a container, bottle or reservoir.

Proponent: Carolinas AGC

Previous Code Cycles	Previous Modification Index Number	Previous Code Section
N/A		



South Carolina Department of Labor, Licensing and Regulation
South Carolina Building Codes Council
2021 Modification Index

Applicable Code: 2021 International Plumbing Code

Modification Index Number: IPC 2021-05

Code Section: Table 403.1 Minimum Number of Required Plumbing Fixtures

Modification:

Add column to table - BOTTLE FILLING STATION

Row 3 Educational, under Bottle Filling Station column. add: 1 per 200 with placement of 1 on each floor (or wing, or other building section) and 1 in school food service areas

See Attachment

Proponent: Carolinas AGC

Previous Code Cycles	Previous Modification Index Number	Previous Code Section
N/A		

Table 403.1
Minimum Number of Required Plumbing Fixtures^a (See Sections 403.1.1 and 403.2)

No.	Classification	Description	Water Closets (Urinals: See Section 424.2)		Lava- to-ries		Bathtubs/ Showers	Drinking Fountain (See Section 410)	Other	Bottle Filling Station
			M	F	M	F				
3	Educational	Educational Facilities	1 per 50		1 per 50		-	1 per 100	1 service sink	<u>1 per 200 with placement of 1 on each floor (or wing or other building section) and 1 in school food service areas.</u>



South Carolina Department of Labor, Licensing and Regulation
South Carolina Building Codes Council
2021 Modification Index

Applicable Code: 2021 International Plumbing Code

Modification Index Number: IPC 2021-06

Code Section: 410.4 Substitution

Modification:

410.4 Substitution. Where restaurants provide drinking water in a container free of charge, drinking fountains shall not be required in those restaurants. In other *occupancies* where three or more drinking fountains are required, *water dispensers* shall be permitted to be substituted for not more than 50 percent of the required number of drinking fountains. In educational settings, 50 percent of the required number of drinking fountains must incorporate a bottle filling station.

Proponent: Carolinas AGC

Previous Code Cycles	Previous Modification Index Number	Previous Code Section
N/A		



South Carolina Department of Labor, Licensing and Regulation
South Carolina Building Codes Council
2021 Modification Index

Applicable Code: 2021 International Mechanical Code

Modification Index Number: IMC 2021-01

Code Section: 504.9.2 Duct Installation

Modification:

504.9.2 Duct installation. Exhaust ducts shall be supported at intervals not to exceed 8 feet and within 16 inches of each side of a joint that is not installed in a vertical orientation, ~~4-foot (1219 mm) intervals and~~ secured in place, making rigid contact with the duct at not less than 4 equally spaced points or 2/3rds contact if strap is used. All brackets and strapping must be noncombustible. The insert end of the duct shall extend into the adjoining duct or fitting in the direction of airflow. ~~Ducts shall not be joined with screws or similar fasteners that protrude more than 1/8 inch (3.2 mm) into the inside of the duct. The overlap shall comply with Section 603.4.2. Ducts shall not be joined with screws or similar devices that protrude into the inside of the duct.~~ Exhaust ducts shall be sealed in accordance with Section 603.9.

Where dryer exhaust ducts are enclosed in wall or ceiling cavities, such cavities shall allow the installation of the duct without deformation. The duct work may be ovalized as long as it terminates in an approved duct box. Minor imperfections located on the duct, in areas other than along the seam, do not constitute a violation of this section.

Proponent: Building Official Association of South Carolina (BOASC)

Previous Code Cycles	Previous Modification Index Number	Previous Code Section
IMC 2018	IMC 2018 01	504.8.2



South Carolina Department of Labor, Licensing and Regulation
South Carolina Building Codes Council
2021 Modification Index

Applicable Code: 2021 International Mechanical Code

Modification Index Number: IMC 2021-02

Code Section: Table 1103.1 Refrigerant Classification Amount and OEL

Modification:

Footnote:
 c. The ASHRAE Standard 34 flammability classification for this refrigerant is 2L, which is a subclass of Class 2.

Proponent: Air Conditioning, Heating, Refrigeration Institute (AHRI)

Previous Code Cycles	Previous Modification Index Number	Previous Code Section
N/A		



South Carolina Department of Labor, Licensing and Regulation
South Carolina Building Codes Council
2021 Modification Index

Applicable Code: 2021 International Mechanical Code

Modification Index Number: IMC 2021-03

Code Section: 1104.3 System Application Requirements

Modification:

1104.3.1 Air conditioning for human comfort. High probability systems used for human comfort shall use Group A1 or A2L refrigerant. In other than industrial *occupancies* where the quantity in a single independent circuit does not exceed the amount in Table 1103.1, Group B1, B2 and B3 refrigerants shall not be used in high-probability systems for air conditioning for human comfort.

Proponent: Air Conditioning, Heating, Refrigeration Institute (AHRI)

Previous Code Cycles	Previous Modification Index Number	Previous Code Section
N/A		



South Carolina Department of Labor, Licensing and Regulation
South Carolina Building Codes Council
2021 Modification Index

Applicable Code: 2021 International Mechanical Code

Modification Index Number: IMC 2021-04

Code Section: Chapter 15 Referenced Standards

Modification:

CSA	
<u>C22.2 No. 60335-2-40 -2019</u>	<u>Household and Similar Electrical Appliances - Safety - Part 2_40: Particular Requirements for Electrical Heat Pumps, Air-Conditioners and Dehumidifiers - 3rd Edition</u> <u>908.1, 916.1, 918.2, 1101.2</u>
UL	
<u>60335-2-40-17 2019</u>	<u>Household and Similar Electrical Appliances - Safety - Part 2_40: Particular Requirements for Electrical Heat Pumps, Air-Conditioners and Dehumidifiers</u> <u>908.1, 916.1, 918.1, 918.2, 1101.2</u>

Proponent: Air Conditioning, Heating, Refrigeration Institute (AHRI)

Previous Code Cycles	Previous Modification Index Number	Previous Code Section
N/A		



South Carolina Department of Labor, Licensing and Regulation
South Carolina Building Codes Council
2021 Modification Index

Applicable Code: 2021 International Fuel Gas Code

Modification Index Number: IFGC 2021-01

Code Section: 401.9 Identification

Modification:

401.9 Identification. Each length of pipe and tubing and each pipe fitting, utilized in a fuel gas system, shall bear the identification of the manufacturer.

Exceptions:

1. Steel pipe sections that are 2 feet (610 mm) and less in length and are cut from longer sections of pipe.
2. Steel pipe fittings 2 inches and less in size.
3. Where identification is provided on the product packaging or crating.
4. Where other *approved* documentation is provided.

Section deleted without substitution.

Proponent: South Carolina Propane Gas Association (SCPGA)

Previous Code Cycles	Previous Modification Index Number	Previous Code Section
IFGC 2018	IFGC 2018 01	401.9
IFGC 2015	IFGC 2015 01	401.9
IFGC 2012	IFGC 2012 01	401.9



South Carolina Department of Labor, Licensing and Regulation
South Carolina Building Codes Council
2021 Modification Index

Applicable Code: 2021 International Fuel Gas Code

Modification Index Number: IFGC 2021-02

Code Section: 401.10 Third-Party Testing and Certification

Modification:

401.10 Piping materials standards. Piping, tubing and fittings shall be manufactured to the applicable referenced standards, specifications and performance criteria listed in Section 403 and shall be identified in accordance with Section 401.9. **Third-party testing and certification.** All piping, tubing and fittings shall comply with the applicable referenced standards, specifications and performance criteria of this code, including Section 403 of the South Carolina Fuel Gas Code and corresponding sections.

Proponent: South Carolina Propane Gas Association (SCPGA)

Previous Code Cycles	Previous Modification Index Number	Previous Code Section
IFGC 2018	IFGC 2018 02	401.10
IFGC 2015	IFGC 2015 02	401.10
IFGC 2012	IFGC 2012 02	401.10



South Carolina Department of Labor, Licensing and Regulation
South Carolina Building Codes Council
2021 Modification Index

Applicable Code: 2021 International Fuel Gas Code

Modification Index Number: IFGC 2021-03

Code Section: 412.4 Listed Equipment

Modification:

[F] 412.4 Listed equipment. Hoses, hose connections, vehicle fuel connections, dispensers, LP-gas pumps and electrical equipment used for LP-gas shall comply with the requirements of NFPA 58 *be listed*.

Proponent: South Carolina Propane Gas Association (SCPGA)

Previous Code Cycles	Previous Modification Index Number	Previous Code Section
IFGC 2018	IFGC 2018 03	412.4
IFGC 2015	IFGC 2015 03	412.4
IFGC 2012	IFGC 2012 03	412.4



South Carolina Department of Labor, Licensing and Regulation
South Carolina Building Codes Council
2021 Modification Index

Applicable Code: 2021 International Fuel Gas Code

Modification Index Number: IFGC 2021-04

Code Section: 412.6 Location

Modification:

[F] 412.6 Location. The point of transfer for LP-gas dispensing operations shall be separated from buildings and other exposures in accordance with the following:

1. Not less than 25 feet (7620 mm) from buildings where the exterior wall is not part of a fire-resistance-rated assembly having a rating of 1 hour or greater.
2. Not less than 25 feet (7620 mm) from combustible overhangs on buildings, measured from a vertical line dropped from the face of the overhang at a point nearest the point of transfer.
3. Not less than 25 feet (7620 mm) from the lot line of property that can be built upon.
4. Not less than 25 feet (7620 mm) from the centerline of the nearest mainline railroad track.
5. Not less than 10 feet (3048 mm) from public streets, highways, thoroughfares, sidewalks and driveways.
6. Not less than 10 feet (3048 mm) from buildings where the exterior wall is part of a fire-resistance-rated assembly having a rating of 1 hour or greater.

In addition to the fuel dispensing requirements of the South Carolina Fire Code, the point of transfer for dispensing operations shall be 25 feet (7620 mm) or more from buildings having combustible exterior wall surfaces, buildings having noncombustible exterior wall surfaces that are not part of a 1-hour fire-resistance-rated assembly or buildings having combustible overhangs, property which could be built on, and railroads; and at least 10 feet (3048 mm) from public streets or sidewalks and buildings having noncombustible exterior wall surfaces that are part of a fire-resistance-rated assembly having a rating of 1 hour or more; and 5 feet from driveways.

Exceptions:

1. The point of transfer for LP-gas dispensing operations need not be separated from canopies providing weather protection for the dispensing equipment that are constructed in accordance with the International Building Code and that provide weather protection for the dispensing equipment. Liquefied petroleum gas containers shall be located in accordance with the International Fire Code.
2. The separation from driveways is not required where the driveway serves the vehicle fuel dispenser.

Liquefied petroleum gas containers shall be located in accordance with the International Fire Code. Liquefied petroleum gas storage and dispensing equipment shall be located outdoors and in accordance with the International South Carolina Fire Code.

Proponent: South Carolina Propane Gas Association (SCPGA)

Previous Code Cycles	Previous Modification Index Number	Previous Code Section
IFGC 2018	IFGC 2018 04	412.6
IFGC 2015	IFGC 2015 04	412.6
IFGC 2012	IFGC 2012 04	412.6



South Carolina Department of Labor, Licensing and Regulation
South Carolina Building Codes Council
2021 Modification Index

Applicable Code: 2021 International Fuel Gas Code

Modification Index Number: IFGC 2021-05

Code Section: 412.8.3 Vehicle Impact Protection

Modification:

[F] 412.8.3 Vehicle impact protection. Where installed within 10 feet (3048 mm) of vehicle traffic, LP-gas storage containers, pumps and dispensers shall be protected in accordance with Section 2307.5, Item 2 of the International Fire Code.

Exception: An alternative method may be used that meets the intent of this section with the approval of the AHJ.

Proponent: South Carolina Propane Gas Association

Previous Code Cycles	Previous Modification Index Number	Previous Code Section
IFGC 2018	IFGC 2018 06	412.8.3
IFGC 2015	IFGC 2015 05	412.8.3
IFGC 2012	IFGC 2012 05	412.7.3



South Carolina Department of Labor, Licensing and Regulation
South Carolina Building Codes Council
2021 Modification Index

Applicable Code: 2021 International Fuel Gas Code

Modification Index Number: IFGC 2021-06

Code Section: 412.10 Private fueling of motor vehicles

Modification:

412.10 Private fueling of motor vehicles. Self-service LP-gas dispensing systems, including key, code and card lock dispensing systems, shall not be open to the public. In addition to the requirements of the South Carolina Fire Code, self-service LP-gas dispensing systems shall be provided with an emergency shutoff switch located within 100 feet (30 480 mm) of, but not less than 20 feet (6096 mm) from, dispensers and the owner of the dispensing facility shall ensure the safe operation of the system and the training of users.

Proponent: South Carolina Propane Gas Association (SCPGA)

Previous Code Cycles	Previous Modification Index Number	Previous Code Section
IFGC 2018	IFGC 2018 07	412.10
IFGC 2015	IFGC 2015 06	412.10
IFGC 2012	IFGC 2012 06	412.8



South Carolina Department of Labor, Licensing and Regulation
South Carolina Building Codes Council
2021 Modification Index

Applicable Code: 2021 International Fuel Gas Code

Modification Index Number: IFGC 2021-07

Code Section: 505.1.1 Commercial cooking appliances vented by exhaust hoods

Modification:

505.1.1 Commercial cooking appliances vented by exhaust hoods. Where commercial cooking appliances are vented by means of the Type I or II kitchen exhaust hood system that serves such appliances, the exhaust system shall be fan powered and the appliances shall be interlocked with the exhaust hood system to prevent appliance operation when the exhaust hood system is not operating. ~~The method of interlock between the exhaust hood system and the appliances equipped with standing pilot burner ignition systems shall not cause such pilots to be extinguished.~~ Where a solenoid valve is installed in the gas piping as part of an interlock system, gas piping shall not be installed to bypass such valve. Dampers shall not be installed in the exhaust system.

Exception: An interlock between the cooking appliance(s) and the exhaust hood system shall not be required for appliances that are of the manually operated type and are factory equipped with standing pilot burner ignition systems. ~~where heat sensors or other approved methods automatically activate the exhaust hood system when cooking operations occur.~~

Proponent: Piedmont Natural Gas

Previous Code Cycles	Previous Modification Index Number	Previous Code Section
IFGC 2018	IFGC 2018 08	505.1.1
IFGC 2015	IFGC 2015 07	505.1.1
IFGC 2012	IFGC 2012 07	505.1.1
IFGC 2006	IFGC 2006 01	505.1.1
IFGC 2003 & 2000	IFGC 2003 02,IFGC 2000 02	505.1.1



South Carolina Department of Labor, Licensing and Regulation
South Carolina Building Codes Council
2021 Modification Index

Applicable Code: 2020 National Electrical Code

Modification Index Number: NEC 2020-03

Code Section: 210.8(A)(5) Dwelling Units

Modification:

210.8(A) Dwelling Units. All 125-volt ~~through 250-volt~~ receptacles installed in the locations specified in 210.8(A)(1) through (A)(11) and supplied by single-phase branch circuits rated 150 volts or less to ground shall have ground-fault circuit-interrupter protection for personnel.

- (1) Bathrooms.
 - (2) Garages and also accessory buildings that have a floor located at or below grade level not intended as habitable rooms and limited to storage areas, work areas, and areas of similar use.
 - (3) Outdoors.
Exception to (3): Receptacles that are not readily accessible and are supplied by a branch circuit dedicated to electric snow-melting, deicing, or pipeline and vessel heating equipment shall be permitted to be installed in accordance with 426.28 or 427.22, as applicable.
 - (4) Crawl spaces - at or below grade level.
 - (5) Basements
Exception No. 1 to (5): A receptacle supplying only a permanently installed fire alarm or burglar alarm system shall not be required to have ground-fault circuit-interrupter protection.
Exception No. 2 to (5): Receptacles in walk-out basements are excluded from this requirement.
- Receptacles installed under the exception to 210.8(A)(5) shall not be considered as meeting the requirements of 210.52(G).
- (6) Kitchens - where the receptacles are installed to serve the countertop surfaces.
 - (7) Sinks - where receptacles are installed within 1.8 m (6 ft) from the top inside edge of the bowl of the sink.
 - (8) Boathouses.
 - (9) Bathtubs or shower stalls - where receptacles are installed within 1.8 m (6 ft) of the outside edge of the bathtub or shower stall.
 - (10) Laundry areas.
Exception to (1) through (3), (5) through (8), and (10): Listed locking support and mounting receptacles utilized in combination with compatible attachment fittings installed for the purpose of serving a ceiling luminaire or ceiling fan shall not be required to be ground-fault circuit-interrupter protected. If a general-purpose convenience receptacle is integral to the ceiling luminaire or ceiling fan, GFCI protection shall be provided.
 - (11) Indoor damp and wet locations.

Proponent: Home Builders Association of South Carolina

Previous Code Cycles	Previous Modification Index Number	Previous Code Section
N/A		



South Carolina Department of Labor, Licensing and Regulation
South Carolina Building Codes Council
2021 Modification Index

Applicable Code: 2020 National Electrical Code

Modification Index Number: NEC 2020-04

Code Section: 210.8(F) Outdoor Outlets

Modification:

210.8(F) Outdoor Outlets. All outdoor outlets for dwellings, other than those covered in 210.8(A)(3), Exception to (3), that are supplied by single-phase branch circuits rated 150 volts to ground or less, 50 amperes or less, shall have ground-fault circuit-interrupter protection for personnel.

Exception: Ground-fault circuit-interrupter protection shall not be required on lighting outlets other than those covered in 210.8(C).

Proponent: Home Builders Association of South Carolina

Previous Code Cycles	Previous Modification Index Number	Previous Code Section
N/A		



South Carolina Department of Labor, Licensing and Regulation
South Carolina Building Codes Council
2021 Modification Index

Applicable Code: 2020 National Electrical Code

Modification Index Number: NEC 2020-05

Code Section: 210.12(A) Dwelling Units

Modification:

210.12(A) Dwelling Units. All 120_volt, single_phase, 15_ and 20_ ampere branch circuits supplying outlets or devices installed in dwelling unit ~~kitchens~~; family rooms, dining rooms, living rooms, parlors, libraries, dens, bedrooms, sunrooms, recreation rooms, closets, hallways, ~~laundry areas~~, or similar rooms or areas shall be protected by any of the means described in 210.12(A)(1) through (6):

Items (1) through (6) and Exception to remain as written.

Proponent: Home Builders Association of South Carolina

Previous Code Cycles	Previous Modification Index Number	Previous Code Section
N/A		



South Carolina Department of Labor, Licensing and Regulation
South Carolina Building Codes Council
2021 Modification Index

Applicable Code: 2020 National Electrical Code

Modification Index Number: NEC 2020-06

Code Section: 230.67 Surge Protection

Modification:

230.67 Surge Protection.

~~(A) Surge-Protective Device.~~ All services supplying dwelling units shall be provided with a surge-protective device (SPD).

~~(B) Location.~~ The SPD shall be an integral part of the service equipment or shall be located immediately adjacent thereto.

Exception: The SPD shall not be required to be located in the service equipment as required in (B) if located at each next level distribution equipment downstream toward the load.

~~(C) Type.~~ The SPD shall be a Type 1 or Type 2 SPD.

~~(D) Replacement.~~ Where service equipment is replaced, all of the requirements of this sections shall apply.

This section is deleted without substitution.

Proponent: Home Builders Association of South Carolina

Previous Code Cycles	Previous Modification Index Number	Previous Code Section
N/A		

Richland County Council Request for Action

Subject:

Department of Public Works – Engineering Division - Comprehensive Transportation Improvement Plan (CTIP) budget and proposed projects for Fiscal Year 2023 (FY-23)

Notes:

October 25, 2022 – The Development & Services Committee recommended Council approve the Comprehensive Transportation Improvement Plan (CTIP), the proposed budgets, and the proposed projects for FY23.



Agenda Briefing

Prepared by:	Shirani Fuller, PE	Title:	County Engineer
Department:	Public Works	Division:	Engineering
Date Prepared:	September 13, 2022	Meeting Date:	October 25, 2022
Legal Review	Patrick Wright via email	Date:	October 5, 2022
Budget Review	Abhijit Deshpande via email	Date:	October 7, 2022
Finance Review	Stacey Hamm via email	Date:	October 5, 2022
Approved for consideration:	Assistant County Administrator	John M. Thompson, Ph.D., MBA, CPM, SCEM	
Meeting/Committee	Development & Services		
Subject	Comprehensive Transportation Improvement Plan (CTIP) budget and proposed projects for Fiscal Year 2023 (FY-23)		

RECOMMENDED/REQUESTED ACTION:

Staff recommends that County Council approve the Comprehensive Transportation Improvement Plan (CTIP), the proposed budgets, and the proposed projects for Fiscal Year 2023.

Request for Council Reconsideration: Yes

FIDUCIARY:

Are funds allocated in the department’s current fiscal year budget?	<input checked="" type="checkbox"/>	Yes	<input type="checkbox"/>	No
If not, is a budget amendment necessary?	<input type="checkbox"/>	Yes	<input type="checkbox"/>	No

ADDITIONAL FISCAL/BUDGETARY MATTERS TO CONSIDER:

The projects will be funded by the approved Department of Public Works (DPW) Capital Road Maintenance budget. Applicable projects that may be funded by County Transportation Committee (CTC) grants will be removed from the Road Maintenance budget. In the event that additional funding becomes available, DPW staff will return to Council to expand the list of projects to closely match with the value funded by the CTC. There should be no fiscal impact in excess of Richland County’s existing budget.

Applicable department/grant key and object codes:

OFFICE OF PROCUREMENT & CONTRACTING FEEDBACK:

Not applicable.

COUNTY ATTORNEY’S OFFICE FEEDBACK/POSSIBLE AREA(S) OF LEGAL EXPOSURE:

There are no legal concerns regarding this matter.

REGULATORY COMPLIANCE:

The preparation and submission of the annual CTIP is in accordance with Chapter 21 of the Richland County Code of Ordinances.

MOTION OF ORIGIN:

There is no associated Council motion of origin.

Council Member	
Meeting	
Date	

STRATEGIC & GENERATIVE DISCUSSION:

This is the third annual Comprehensive Transportation Improvement Plan (CTIP) created by the Richland County Department of Public Works (DPW) staff. This plan was first prepared and presented to Council for approval in 2020. Our purpose remains unchanged: to improve the process of restoring and preserving the County Road Maintenance System (CRMS) using analytical methods. DPW completed a pavement management study in 2021 to update the Pavement Condition Index (PCI) values for all County roads. Automated inspection equipment including using high resolution video and laser sensors were used to measure common pavement distresses and then correlate them to a PCI value. The recent study was used to create this year’s resurfacing and preservation list with updated pavement conditions.

Funding remains the limited resource in the maintenance and improvement of County roads. Approval of the CTIP provides County staff the ability to seek outside funding sources such as "C" Funds which is an essential source of funding for the County's transportation infrastructure.

The Transportation Penny Program operates in conjunction with DPW adding to the miles of roadway replaced and preserved each year in Richland County.

ADDITIONAL COMMENTS FOR CONSIDERATION:

None.

ATTACHMENTS:

1. Fiscal Year 2023 (FY-23) Comprehensive Transportation Improvement Plan (CTIP)



County Road Maintenance System (CRMS)

Fiscal Year 2023 (FY-23) Annual Comprehensive Transportation Improvement Program (CTIP)

Updated: August 29, 2022

References: (a) *Richland County Code of Ordinances*, Chapter 21
(b) Richland County Department of Public Works County Road Maintenance System Management Standard Operating Procedures, June 30, 2020

Enclosures: (1) RDM Maintenance Area road type / mileage breakdown
(2) County Council District road type / mileage breakdown
(3) IGA road type / small municipality / mileage breakdown
(4) Bridges / type / location
(5) Rail Crossings / type / location
(6) Traffic / crossing lighted signals
(7) Sidewalks

Section 1 – Introduction:

The Department of Public Works has completed its second year of a coordinated effort to account for, document, maintain, and improve the Richland County Road Maintenance System (CRMS). Last fiscal year the Department of Public Works produced its first Annual Roads Report detailing the accomplishments of Roads and Drainage, Engineering, and Transportation Departments efforts to improve assets in the CRMS during the 2021 fiscal year.

The Department used its second Pavement Management Study (PMS) to assess the condition of all County-maintained paved roads to develop this year's Comprehensive Transportation Improvement Plan.

The Department's Capital Improvement Projects (CIP) in FY22 were funded strictly through grants from the County Transportation Committee due to the Road Maintenance Fund for capital projects being on hold. We expect to see resolution on this issue during the 2023 fiscal year so that we can better serve the residents of Richland County.

Section 2 – System Description:

The Richland County Road Maintenance System (CRMS) is composed of road and road-related infrastructure that is, by assigned mission, or intergovernmental agreement (IGA), owned, and / or maintained by the Department of Public Works (DPW). Such infrastructure is, in some way, available for public use and represents a variety of levels of development, design, and construction source.

Section 3 – System Data:

<input type="checkbox"/> Road mileage (unpaved – Prescriptive Easement)	157 miles
<input type="checkbox"/> Road mileage (unpaved – Right-of-Way)	46 miles
<input type="checkbox"/> Road mileage (paved)	633 miles
<input type="checkbox"/> Road mileage (paved – approximate incoming ROW)	6 miles
<input type="checkbox"/> RDM Maintenance Area breakdown	See Enclosure (1)
<input type="checkbox"/> County Council District breakdown	See Enclosure (2)
<input type="checkbox"/> IGA road mileage (by surface type / by small municipality)	See Enclosure (3)
<input type="checkbox"/> Bridges (by type and location)	See Enclosure (4)
<input type="checkbox"/> Rail Crossings	See Enclosure (5)
<input type="checkbox"/> Traffic and crossing lighted signals	See Enclosure (6)
<input type="checkbox"/> Sidewalk mileage	See Enclosure (7)

Section 4 – Programs / Functions:

Department of Public Works

Roads & Drainage Maintenance (RDM)

- Citizen Service Request (CSR) response / Corrective maintenance (Level of Service - LOS) – CSRs are generated from services requested through County Ombudsman staff. Responsibilities include receiving and responding to requests for service and other related inquiries from County residents. Typical level of activity is 6,000 CSRs received annually (500 per month). The typical backlog of pending CSRs, which varies by season, weather events, and other factors beyond departmental control, is usually 100 or fewer.
- Emergency response (LOS) – Requests of an emergent nature include: buried drainage pipe failure / cave in, downed STOP signs, animal carcasses within CRMS right-of-way and easements, potholes, leaning signs, manhole lids missing or askew, excess sand or grit on a paved road, tree hazards and downed trees in the road. These must be assigned immediately, the hazard mitigated as soon as possible, and all work completed within hours or days.

- Force Account (“in-house” staff and equipment) Projects (LOS) – Sometimes roads and drainage infrastructure deficiencies require more than routine maintenance. Multiple drainage pipe joint failures, undersized drainage pipes, failed drainage structures, and outdated infrastructure may require a level of engineering analysis and construction effort that exceeds basic levels of maintenance. The County Engineering and Stormwater Management Division work in close cooperation with the Projects Section of the Roads & Drainage Maintenance Division to design, manage, and construct smaller scale projects that support the CRMS. There is typically a backlog of eight projects of varying sizes and scopes.
- Preventive maintenance (LOS) – Maximize preventive maintenance (PM) of all types based on observations by employees in the field in order to ensure properly maintained infrastructure and reduce the need for CSRs.
- Sign maintenance (LOS) – Installation, maintenance and repair of street name signs throughout the unincorporated County and IGA municipalities for all public and private roads and streets. Installation, maintenance and repair of directional and warning signs within the CRMS. Because of their vital nature, sign-related requests are assigned a high priority.
- Street sweeping (LOS) – Deploy the street sweeper for the removal of grit, sediment, and debris from the CRMS, County-paved parking lots, and the Jim Hamilton – LB Owens Airport (CUB) pavement in order to preserve pavement, prevent debris from entering the drainage system, improve appearance, and control foreign object debris. Achieve an employment goal of 40% (780 hours of operation over a 52-week period). Note: A second street sweeper was added to the RDM Fleet during FY-22 in a joint effort with the Stormwater Management Division.
- Vactor truck services (LOS) – Deploy the two Vactor trucks to ensure that the drainage system, which supports the CRMS and area drainage, is free of blockages and debris. Priority of employment is: 1) Response to CSRs, 2) Preventive Maintenance (PM), and 3) neighborhood drainage system maintenance as identified by the Stormwater Management Division. Achieve an employment goal of 40% (780 hours of operation per truck over a 52-week period).

Engineering (EGR)

- County Transportation Committee (CTC) – The Department of Public Works acts as the lead agency to coordinate with the County Transportation Committee (CTC). The CTC provides “C” Fund Grants for CRMS transportation projects to include:
 - Resurfacing
 - Sidewalk installation
 - Dirt road paving
 - Other transportation improvements
- See the FY-23 Capital Improvement Plan (CIP) in Section 7 for specific projects in progress or planned for future construction. The Richland County liaison to the CTC is the County Engineer.



- Pavement marking maintenance (LOS) – The Department of Public Works maintains a limited inventory of pavement markings throughout the County on some CRMS paved roads that meet the criteria for such markings. One Stop service requests will be investigated by Engineering Division staff to evaluate the functionality and standard compliance along with condition and serviceability. Markings in need of installation, repair or replacement will be added to the annual Pavement Marking Maintenance List for repair or replacement by the on-call service contractor. One Stop citizen notification and update shall occur per Ombudsman policy and procedure. The current annual budget is \$20,000.
- Signal maintenance (LOS) – The Department of Public Works maintains an inventory of traffic signals and flashing school zone lights. Both systems are managed by the Engineering Division staff under the direction and supervision of the County Engineer; once notified, Engineering will investigate any device issues (alignment, system failures, light outage and damage) that may affect traffic safety. The on-call maintenance contractor shall be available when required to make immediate repairs. The contractor is also responsible for installing of overhead road signage at intersections as directed by the County. Renewal of contracts and maintenance budgets is required and must be updated on an as-needed basis. The current annual budget is \$20,000.
- Traffic calming – The Department of Public Works installs speed humps on paved roads within the CRMS and SCDOT-maintained public roads. The installation of traffic calming devices shall be considered only when it has been determined by Engineering Division staff that the roadway meets all criteria and after a petition and supporting documentation have been submitted for review. A citizen Point of Contact (POC) shall be assigned to represent the neighborhood or subject street. The POC must be willing to work with DPW staff throughout the traffic calming device request process. Upon receiving the request, DPW staff will perform a review of the subject street to ensure the street meets all criteria referenced in the traffic calming warrants. The Department performs traffic studies and installs approximately 10 speed humps per year.
- Unpaved road dust suppression (LOS) – The Department of Public Works maintains an inventory of approximately 200 miles of unpaved roads. Application of calcium chloride to these roads for dust suppression reduces suspended dust particles that affect traffic safety and property. An annual list of roads is developed through the Engineering Division and the Roads & Drainage Maintenance Division. These roads are sprayed with one application of calcium chloride by a contracted road treatment service. The current annual budget is \$90,000. Due to recent price inflation, this treated approximately 31 miles of unpaved roads in FY22 (15% of the unpaved portion of the CRMS).

Special Services (SS)

- Roadside Litter Pickup (LOS) – The Special Services Division employs inmate labor work crews to police public road right-of-way to include the CRMS and SCDOT-maintained roads. After a service interruption due to the COVID-19 pandemic, the inmate labor availability has generally been restored with only brief interruptions. However, roadside litter pickups during FY-22 were less reliable than in previous years.

Other County Departments:

Transportation Penny Department

The Transportation Penny Tax Program, which was approved by the residents of Richland County in 2012, provides funding for a wide range of transportation improvement projects throughout the County. The following projects are anticipated for completion during FY-23:

Dirt Road Paving:

Road Name	District	Linear Miles	Dept
Summer Haven Dr, Phase 2	1	0.09	Transportation
Vallenga Dr	9	0.32	Transportation
Cornell Adams Run	11	0.47	Transportation

Road Resurfacing:

Road Name	District	Linear Miles	Dept
Bamboo Grove Ct	1	0.10	Transportation
Charlwood Ct	1	0.03	Transportation
Chatteris Rd	1	0.08	Transportation
Cockspur Cir	1	0.09	Transportation
Crayford Rd	1	0.17	Transportation
Deer Tract Dr	1	0.52	Transportation
Doncaster Ct	1	0.04	Transportation
E Creek Ct	1	0.16	Transportation
Freestone Dr	1	0.06	Transportation
Hawks Ridge Ct	1	0.06	Transportation
Hever Ct	1	0.02	Transportation
Jarrold Ct	1	0.05	Transportation
Jim Koon Rd	1	0.12	Transportation
Kirton Ct	1	0.03	Transportation
Rock Hampton Rd	1	0.22	Transportation
Rushing Wind Dr	1	0.37	Transportation
Stonewall Ct	1	0.12	Transportation
Stoney Point Ln	1	0.35	Transportation
Tapp Pt	1	0.12	Transportation
Timberlake Ct	1	0.01	Transportation
Top Flight Ct	1	0.10	Transportation
Treyburn Rd	1	0.11	Transportation
Wenlock Cir	1	0.19	Transportation

Woodglen Ln	1	0.08	Transportation
Woodhouse Ct	1	0.05	Transportation
Chillingham Rd	1	0.23	Transportation
Harleston Rd	1	0.14	Transportation
Signal Ln	1	0.21	Transportation
Silver Lake Cir	1	0.34	Transportation
Arbor Oaks Ct	2	0.04	Transportation
Cape Flattery Ct	2	0.12	Transportation
Hunter Hill Rd	2	0.68	Transportation
Lakewood Cir	2	0.15	Transportation
S Mercer Ct	2	0.03	Transportation
Nevamar Dr	3	0.11	Transportation
Newcastle Dr	3	0.26	Transportation
North Hunters Ct	3	0.06	Transportation
Saxonbury Dr	3	0.06	Transportation
Whitmell Ave	3	0.13	Transportation
S Hunters Ct	3	0.05	Transportation
Alcott Dr	4	0.07	Transportation
Briar Ln	6	0.07	Transportation
Beaver Creek Cir	7	0.02	Transportation
Bedford Dr	7	0.04	Transportation
Bennie Dr	7	0.05	Transportation
Cordova Dr	7	0.17	Transportation
Crooked Stick Ct	7	0.04	Transportation
Ellafair Ln	7	0.05	Transportation
Lee Ridge Ct	7	0.25	Transportation
Pelican Cir	7	0.12	Transportation
Springcrest Dr	7	0.14	Transportation
Sunmeadow Dr	7	0.10	Transportation
Harrington Ct	8	0.12	Transportation
Auburncrest Ct	8	0.03	Transportation
Berry Ridge Cir	8	0.35	Transportation
Brookmist	8	0.21	Transportation
Cambridge Oaks Ct	8	0.03	Transportation
Cambridge Oaks Dr	8	0.40	Transportation
Cobblestone Ct	8	0.02	Transportation
Dovecreek	8	0.31	Transportation
Innis Ct	8	0.05	Transportation
Ridge Pond Dr	8	0.10	Transportation
Woodbranch Rd	8	0.15	Transportation
Sesqui Trl	9	0.15	Transportation



Sesqui Trl	9	0.09	Transportation
Brassie Ct	9	0.10	Transportation
Hunt Cup Ln	9	0.05	Transportation
Old Still Rd W	9	0.20	Transportation
Shallow Brook Dr	9	0.66	Transportation
Walden Oak Ct	9	0.03	Transportation
Waterton Way	9	0.14	Transportation
Acme St	10	0.12	Transportation
Carlow Dr	11	0.19	Transportation
Flowerwood Ct	11	0.06	Transportation
Pisgah Dr	11	0.10	Transportation
Saxon Shore Rd	11	0.15	Transportation

Section 5 – Resources within the Department of Public Works:

- Road Maintenance FY-22 Fund Balance(preliminary) \$12,045,868
- RDM FY-23 Operating Budget \$8,083,166
- “C” Fund Forecasted Appointment \$5,286,900

Section 6 – Goals:

DPW

- Funding source – Work with County Council and County Administration to ensure an adequate, reliable, steady, and uninterrupted funding source for Roads and Drainage Maintenance operations and improvement projects in light of the recent state Supreme Court decision and subsequent lawsuit against the County.
- Interdepartmental coordination – Improve interdepartmental coordination with other stakeholders, especially the Transportation Penny staff, to ensure that all projects are coordinated, mutually supporting, and maintain or enhance area drainage.
- Interdepartmental coordination – Improve interdepartmental coordination with other stakeholders, especially the Community Planning and Development Department, to ensure that updated development standards are properly applied and newly developed infrastructure is of sufficient quality.

RDM

- Process review – Continue working with the staff of the Information Technology (IT) Department, fully develop and implement the reporting component of the Work Order System (WOS) in order to establish performance benchmarks and better analyze activity, service, and productivity.



- Personnel management – Emphasize the prompt hiring of qualified applicants to fill vacancies as they occur. Develop a Master Equipment Operator to promote training, professional development, and skill quality of Equipment Operators.
- Facility Improvement – Continue to develop the Blythewood area work camp that services the Northern portion of the County.
- Purchase replacement equipment needed to bring the fleet up to a higher level of service. Equipment to include a vactor truck, two dump trucks, two mini-excavators, and two skid steer loaders.

EGR

- Asset Inventory –Identify a system for managing County infrastructure with the ability to update information on assets and produced reports to assist with decision making.
- Develop and implement an inspection and maintenance schedule for sidewalks and Shared Use Paths (SUP) in the CRMS.

SS

- Develop a schedule and perform recurring, adequate vegetation maintenance for all sidewalks and SUPs in the CRMS in order to prevent slip and trip hazards and provide attractive community aesthetics.



Section 7 – Capital Improvement Plan (CIP):

Item Description	Proposed Funding Source	FY21	Biennium		Biennium		Total
			FY22	FY23	FY24	FY25	
Unpaved Roadway Repair-Design	RMF	\$100,000	\$100,000	\$100,000	\$100,000	\$100,000	\$500,000
Unpaved Roadway Repair-Construction	RMF	\$400,000	\$400,000	\$400,000	\$400,000	\$400,000	\$2,000,000
Sidewalk Capital Improvement	RMF	\$350,000					\$350,000
Miscellaneous Road Improvements	RMF	\$50,000	\$50,000	\$50,000	\$50,000	\$50,000	\$250,000
Road Resurfacing	RMF		\$1,000,000	\$1,000,000	\$1,000,000	\$1,000,000	\$4,000,000
Pavement Preservation	"C" Funds	\$500,000	\$500,000	\$500,000	\$500,000	\$500,000	\$2,500,000
Resurfacing Roads	"C" Funds	\$1,000,000	\$2,000,000	\$2,000,000	\$2,000,000	\$2,000,000	\$9,000,000
New Sidewalks	"C" Funds	\$1,000,000	\$500,000	\$500,000	\$500,000	\$500,000	\$3,000,000
New Sidewalk-Design	TAP		\$100,000	\$50,000	\$100,000	\$50,000	\$300,000
New Sidewalk-Construction	TAP			\$1,000,000		\$1,000,000	\$2,000,000
Totals		\$5,000,000	\$4,650,000	\$5,600,000	\$4,650,000	\$5,600,000	\$25,500,000

Note 1: Road Maintenance Fund (RMF) / Transportation Assistance Program (TAP)

Note 2: See Section 4 – Programs / functions: Other County Departments / Transportation Penny Department for planned Fiscal Year 2023 paving and resurfacing projects planned under that program.



FY-22 Capital Improvement Plan (CIP)

Pavement Preservation:

Road Name	District	Linear Miles	Dept
Wade Kelly Rd	2	1.24	DPW
Ray Kelly Rd	2	0.31	DPW
Soft Stone Dr	2	0.40	DPW
Eastbrook Rd	3	0.15	DPW
Westbrook Rd	3	0.09	DPW
Hoyt St	3	0.14	DPW
Summer Pines Dr	7	0.36	DPW
Summer Brook Ct	7	0.08	DPW
Joshua Tree Ct	7	0.16	DPW
Apple Branch Ct	7	0.15	DPW
Pine Sapp Dr	7	0.12	DPW
Abbott Rd	10	0.41	DPW
Total		3.61	

Road Repair and Resurfacing:

Road Name	District	Linear Miles	Dept
Chadford Rd	1	0.82	DPW
Ivy Green Ln	1	0.34	DPW
Ivy Green Ct	1	0.05	DPW
Ivy Green Cir	1	0.20	DPW
Ivy Gate Ct	1	0.05	DPW
Arbor Oaks Cir	2	0.14	DPW
Arbor Oaks Ln	2	0.14	DPW
Hillpine Rd	2	0.34	DPW
Oak Knoll Dr	2	0.40	DPW
Parliament Lake Dr	3	0.15	DPW
Parliament Lake Ct	3	0.04	DPW
Dunbarton Dr	3	0.38	DPW
St Andrews Rd	4	0.30	DPW
Laburnum Dr	5	0.22	DPW
Folkstone Rd	7	0.56	DPW
Great North Rd	7	0.53	DPW
Abbott Rd	10	0.13	DPW
Walcott Rd	10	0.13	DPW

Shorecrest Dr	10	0.39	DPW
Trotwood Dr	11	0.32	DPW
Old South Dr	11	0.27	DPW
Kempshire Blvd	11	0.42	DPW
Cardington Dr	11	0.73	DPW
Cardington Ct	11	0.11	DPW
Raintree Ln	11	0.23	DPW
Total		7.69	

Sidewalk Construction:

Road Name	Start	End	District	Length (ft)
St Andrews Rd	Broad River Rd	End	4	1880
Friarsgate Blvd	Park	Old Well Rd	2	3420
Total				5300

Sidewalk Capital Maintenance:

In addition to new sidewalk construction, \$35,000 is budgeted for the maintaining existing sidewalks within the County Road Maintenance System this fiscal year. Areas for maintenance will be identified by County staff and prioritized to address safety concerns.



Enclosures 1-7



Department of Public Works

County Road Maintenance System (CRMS)

Fiscal Year 2023 Annual Maintenance and Improvement Comprehensive Plan

Updated: June 30, 2022

Enclosure (1) RDM Maintenance Area Road Type / Mileage Breakdown

Unpaved roads

RDM Maintenance Area

	County Owned		Prescriptive Easement		All County Unpaved	
	Length (ft)	Length (miles)	Length (ft)	Length (miles)	Total Length (ft)	Length (miles)
Ballentine	55,049.99	10.43	151,046.20	28.61	206,096.18	39.03
Eastover	98,728.72	18.70	434,489.60	82.29	533,218.32	100.99
Northeast	88,976.51	16.85	243,936.95	46.20	332,913.46	63.05
Total Length	242,755.22	45.98	829,472.75	157.10	1,072,227.96	203.07

Paved roads

RDM Maintenance Area

	County Owned		Municipal Owned		All County Paved	
	Length (ft)	Length (miles)	Length (ft)	Length (Miles)	Total Length (ft)	Length (miles)
Ballentine	674,419.20	127.73	106,154.54	20.11	780,573.74	147.84
Eastover	423,894.05	80.28	0.00	0.00	423,894.05	80.28
Northeast	2,105,665.02	398.80	34,691.08	6.57	2,140,356.10	405.37
Total Length	3,203,978.26	606.81	140,845.62	26.68	3,344,823.88	633.49



County Road Maintenance System (CRMS)
 Fiscal Year 2023 Annual Maintenance and Improvement Comprehensive Plan

Enclosure (2) County Council District Road Type / Mileage Breakdown

Unpaved roads
 Council District

	County Owned (Public ROW)		Prescriptive Easement		All County Unpaved	
	Length (ft)	Length (miles)	Length (ft)	Length (miles)	Total Length (ft)	Length (miles)
1	50,468.40	9.56	142,820.50	27.05	193,288.90	36.61
2	32,161.04	6.09	151,731.70	28.74	183,892.75	34.83
3	2,262.57	0.43	2,270.25	0.43	4,532.82	0.86
4	447.29	0.08	913.53	0.17	1,360.82	0.26
5	2,955.73	0.56	1,368.29	0.26	4,324.02	0.82
6	757.67	0.14	0.00	0.00	757.67	0.14
7	38,935.88	7.37	72,890.20	13.80	111,826.08	21.18
8	5,481.05	1.04	6,415.51	1.22	11,896.56	2.25
9	8,355.17	1.58	7,392.80	1.40	15,747.97	2.98
10	70,458.44	13.34	395,741.00	74.95	466,199.44	88.30
11	30,471.96	5.77	47,928.98	9.08	78,400.94	14.85
Total Length	242,755.22	45.98	829,472.75	157.10	1,072,227.96	203.07

Paved roads
 Council District

	County Owned (Public ROW)		Municipal Owned		All County Paved	
	Length (ft)	Length (miles)	Length (ft)	Length (miles)	Total Length (ft)	Length (miles)
1	523,094.69	99.07	60,091.54	11.38	583,186.23	110.45
2	394,713.18	74.76	54,179.94	10.26	448,893.12	85.02
3	167,829.84	31.79	3,974.05	0.75	171,803.89	32.54
4	45,668.21	8.65	0.00	0.00	45,668.21	8.65
5	14,124.58	2.68	0.00	0.00	14,124.58	2.68
6	17,771.87	3.37	2,808.01	0.53	20,579.88	3.90
7	420,969.60	79.73	19,792.08	3.75	440,761.68	83.48
8	552,657.17	104.67	0.00	0.00	552,657.17	104.67
9	609,602.66	115.46	0.00	0.00	609,602.66	115.46
10	172,768.37	32.72	0.00	0.00	172,768.37	32.72
11	284,778.10	53.94	0.00	0.00	284,778.10	53.94
Total Length	3,203,978.26	606.81	140,845.62	26.68	3,344,823.88	633.49



County Road Maintenance System (CRMS)
 Fiscal Year 2023 Annual Maintenance and Improvement Comprehensive Plan
 Updated: June 30, 2022

Enclosure (3) IGA Road Type / Small Municipality / Mileage Breakdown

Municipality	Paved Roads (miles)	Unpaved Roads (miles)	Total (miles)
Arcadia Lakes	1.57	0	1.57
Blythewood	10.57	3.53	14.09
Cayce	0	1.58	1.58
Eastover	0.94	0.42	1.36
Forest Acres	4.89	0.2	5.09
Irmo	25.76	1.7	27.45
Total (mMiles)	43.73	7.42	51.15



County Road Maintenance System (CRMS)
Fiscal Year 2023 Annual Maintenance and Improvement Comprehensive Plan
Updated: June 30, 2022

Enclosure (4) Bridge / Type / Location

Location	Type
Old Garners Ferry Road at Mill Creek	Concrete slab on piers
White House Road at Gills Creek	Concrete slab on piers
Chinquapin Road at Stoops Creek	Open bottom culvert
Raintree Drive at ditch crossing	Open bottom culvert
Beechwood Lane at ditch crossing	Open bottom culvert



County Road Maintenance System (CRMS)
 Fiscal Year 2023 Annual Maintenance and Improvement Comprehensive Plan
 Updated: June 30, 2022

Enclosure (5) Railroad crossings/type/location

Road Atlas Map Grid	Name of Road	Road Type	Entity in Charge of Inspections	Type of RR Line Crossed	Own r/w on Road	Municipality	SCDOT Crossing	Comments
49B4	Lykesland Trail	Unpaved	County	Main railroad track	Yes	County	723733S	
27D4	Vine Street	Paved	County	Side railroad track	Yes	County	634637U	Crossing between Rosewood Drive and Brookwood Drive
34F1	Mount Pilgrim Church Road	Unpaved	County	Main railroad track	No	County	715899B	
72B2	Gus Lane	Unpaved	County	Main railroad track	No	County	632650B	
32D3	Pine Wedge Drive	Paved	County	Main railroad track	Yes	County	715908X	
27D4	Vine Street	Paved	County	Side railroad track	Yes	County	634638B	Crossing Southeast of Brookwood Drive
37B5	Mauney Drive	Paved	County	Side railroad track	Yes	County	904637R	
27D4	Garland Street	Paved	County	Side railroad track	Yes	County	634642R	Crossing between Rosewood Drive and Brookwood Drive
27D4	Duval Street	Paved	County	Side railroad track	Yes	County	634640C	Crossing between Rosewood Drive and Brookwood Drive
27D4	Duval Street	Paved	County	Side railroad track	Yes	County	634641J	Crossing southeast of Brookwood Drive
27D4	Rosewood Drive	Paved	County	Side railroad track	Yes	County	634636M	
27D4	Garland Street	Paved	County / Columbia	Side railroad track	Part	County and Columbia	634643X	County owns approach from west side of crossing, RR r/w is
27D4	Oakdale Drive	Paved	County	Side railroad track	Yes	County	634644E	Crossing between Rosewood Drive and Brookwood Drive
05B4	Lynn McCartha Road	Unpaved	County	Main railroad track	No	County	843360B	
05B4	Walter McCartha Road	Unpaved	County	Main railroad track	No	County	843359G	
31D4	Frank Dale Road	Unpaved	County	Main railroad track	No	County	715917W	Road is small connector between Frank Dale Road and Gunter Circle
35D4	Cadia Drive	Unpaved	County	Main railroad track	No	County	634296D	
32C2	Boomer Road	Unpaved	County	Main railroad track	No	Blythewood	715910Y	
4.90E+04	Century Oaks Lane	Unpaved	County	Main railroad track	No	County	632196S	
35A4	Fontaine Center Drive	Paved	County	Main railroad track	Yes	County	640941L	
62A2	Third Street	Unpaved	County	Main railroad track	No	County	723729C	RR Crossing is beyond County ownership, connects to Edmonds Farm Road
27F4	Andrews Road	Unpaved	County / Columbia	Side railroad track	No	County and Columbia	904635C	County unpaved road - RR right of way is within City of Columbia
Not on SCDOT (2011) List								
27D3	Olympia Avenue	Paved	County / Columbia	Main railroad track	Part	County and Columbia		County owns approach from west side of crossing
3.20E+05	Wooten Road	Unpaved	County	Main railroad track	No	County		
45F1	Fashion Drive	Paved	County	Main railroad track	Yes	County		



Enclosure (6) Traffic / Crossing Lighted Signals

Traffic Signals

Intersection Location	RDM Maintenance Area
Fashion and Forum Dr	North
Summit Parkway at Summit Ridge	North
Summit Commons at Summit Parkway	North

School Zone Flashing Signal

School	RDM Maintenance Area
HE Corley Elementary	West
Summit Parkway Middle	North



County Road Maintenance System (CRMS)
 Fiscal Year 2023 Annual Maintenance and Improvement Comprehensive Plan
 Updated through March 2021

Enclosure (7) County-Maintained Sidewalks

RDM Maintenance
 Area

	County Owned		Municipal Owned		All County Paved	
	Length (ft)	Length (miles)	Length (ft)	Length (miles)	Total Length (ft)	Length (miles)
Ballentine	318,161.24	60.26	27,202.02	5.15	345,363.26	65.41
Eastover	62,697.20	11.87	0.00	0.00	62,697.20	11.87
Northeast	900,517.83	170.55	5,330.56	1.01	905,848.38	171.56
Total Length	1,281,376.27	242.68	32,532.58	6.16	1,313,908.85	248.85

Council District

	County Owned		Municipal Owned		All County Paved	
	Length (ft)	Length (miles)	Length (ft)	Length (miles)	Total Length (ft)	Length (miles)
1	305,428.05	57.85	18,639.50	3.53	324,067.55	61.38
2	158,926.64	30.10	8,562.52	1.62	167,489.16	31.72
3	29,166.41	5.52	0.00	0.00	29,166.41	5.52
4	6,364.30	1.21	0.00	0.00	6,364.30	1.21
5	0.00	0.00	0.00	0.00	0.00	0.00
6	3,246.30	0.61	0.00	0.00	3,246.30	0.61
7	162,424.42	30.76	5,330.56	1.01	167,754.98	31.77
8	325,382.70	61.63	0.00	0.00	325,382.70	61.63
9	227,740.25	43.13	0.00	0.00	227,740.25	43.13
10	7,466.48	1.41	0.00	0.00	7,466.48	1.41
11	55,230.72	10.46	0.00	0.00	55,230.72	10.46
Total Length	1,281,376.27	242.68	32,532.58	6.16	1,313,908.85	248.85



Richland County Council Request for Action

Subject:

Move to direct the County Administrator to evaluate current zoning laws that permit zoning designations for large residential developments to remain in perpetuity and present options to re-evaluate and or rezone those properties if they are not developed within 7 years. Recommendations should include processes to ensure that zoning and the comprehensive plan remain consistent with the lived character of the community [Newton - July 13, 2021]

Notes:

October 25, 2022 – The Development & Services Committee recommended referring this item to the Planning Commission.

Richland County Council Request for Action

Subject:

Based on the below information, the matter of urban heat mapping should be referred to the Planning Commission for consideration. The expanding residential, commercial and transportation infrastructure contribute to areas where temperatures are much warmer, and that could put people at risk of injury or death on hot days.

“This study will help demonstrate to local governments and others where we need to preserve undeveloped land and trees, plant additional trees or build other green infrastructure to reduce or prevent heat islands in Richland County,” (Quinton) Epps said. (Division Manager, Community Planning and Development Department)
The heat-mapping initiative aims to improve understanding of and guide action to reduce heat health risks, encourage economic development and boost the area’s quality of life overall, therefore, prior to council deciding what zoning needs to be placed in specific areas without having that information would be a dereliction of our duties to the residents of the county. [Malinowski - August 30, 2022]

Notes:

October 25, 2022 – The Development & Services Committee recommended referring this item to the Planning Commission.

Richland County Council Request for Action

Subject:

Department of Public Works - Engineering Division - Summit Ridge/Summit Parkway Project

Notes:

October 25, 2022 – The Administration & Finance Committee recommended Council approve the award the rehabilitation of Summit Parkway and Summit Ridge to Palmetto Corp. in the amount of \$2,114,010.65.

**RICHLAND COUNTY
ADMINISTRATION**

2020 Hampton Street, Suite 4069
Columbia, SC 29204
803-576-2050



Agenda Briefing

Prepared by:	Jennifer Wladischkin	Title:	Director
Department:	Office of Procurement & Contracting	Division:	
Date Prepared:	September 29, 2022	Meeting Date:	October 25, 2022
Legal Review	Patrick Wright via email	Date:	October 10, 2022
Budget Review	Abhijit Desphande via email	Date:	October 4, 2022
Finance Review	Stacey Hamm via email	Date:	October 19, 2022
Approved for consideration:	Assistant County Administrator	John M. Thompson, Ph.D., MBA, CPM, SCEM	
Meeting/Committee	Administration & Finance		
Subject	Rehabilitation of Summit Parkway and Summit Ridge		

RECOMMENDED/REQUESTED ACTION:

Staff recommends Council approval to award the rehabilitation of Summit Parkway and Summit Ridge to Palmetto Corp. in the amount of \$2,114,010.65.

Request for Council Reconsideration: Yes

FIDUCIARY:

Are funds allocated in the department’s current fiscal year budget?	<input checked="" type="checkbox"/>	Yes	<input type="checkbox"/>	No
If not, is a budget amendment necessary?	<input type="checkbox"/>	Yes	<input type="checkbox"/>	No

ADDITIONAL FISCAL/BUDGETARY MATTERS TO CONSIDER:

This project is funded through a grant from the County Transportation Committee. The contractor bid price is within the available grant amount.

Applicable department/grant key and object codes: 1200992030.532200/4811086.532200 - (\$614,473.37)
1200992030.532200/4811087.532200 - (\$1,590,277.53)

OFFICE OF PROCUREMENT & CONTRACTING FEEDBACK:

Request for Bids RC-538-B-23 was issued on August 18. The bid opening was held on September 26, 2022 at 2:00PM. Palmetto Corp. submitted the only response. The bid was evaluated and found to be responsive and responsible. The bid was approximately 4% less than the engineer's estimate for the project. The contractor committed to 2.4% minority/disadvantaged business participation and 1.73% SLBE participation. Procurement recommends award to the lowest, responsive, responsible bidder, Palmetto Corp.

COUNTY ATTORNEY’S OFFICE FEEDBACK/POSSIBLE AREA(S) OF LEGAL EXPOSURE:

There are no legal concerns regarding this matter.

REGULATORY COMPLIANCE:

None applicable.

MOTION OF ORIGIN:

There is no associated Council motion of origin.

Council Member	
Meeting	
Date	

STRATEGIC & GENERATIVE DISCUSSION:

The CTC has granted Public Works funding to rehabilitate Summit Parkway and Summit Ridge. These roads are located in a high density residential area providing access to numerous subdivisions, shopping centers, and a public school. This project will directly benefit the residents of Richland County by providing a sustainable quality roadway for safe travel and improving County owned infrastructure. As this area of the Northeast has grown these roads are receiving substantial higher volumes of traffic. This higher traffic count has led to quicker deterioration of the roadway. Current conditions are beyond the scope of maintenance. A previous attempt to bid out this project returned costs that exceeded the available grant funding. The project was reevaluated and re-scoped to adjust for changes in the construction market and to optimize available techniques. Council has previously taken action on this issue by approving the acceptance of this grant from CTC.

ADDITIONAL COMMENTS FOR CONSIDERATION:

None.

ATTACHMENTS:

1. Bid Tabulation
2. Area Map- Summit Pkwy
3. Area Map- Summit Ridge

RC-538-B-23 Summit Ridge/Summit Pkwy Resurfacing

Due: 9/26/2022 2:00PM

	Palmetto Corp of Conway
Total Cost	\$2,114,010.65

Summit Pkwy

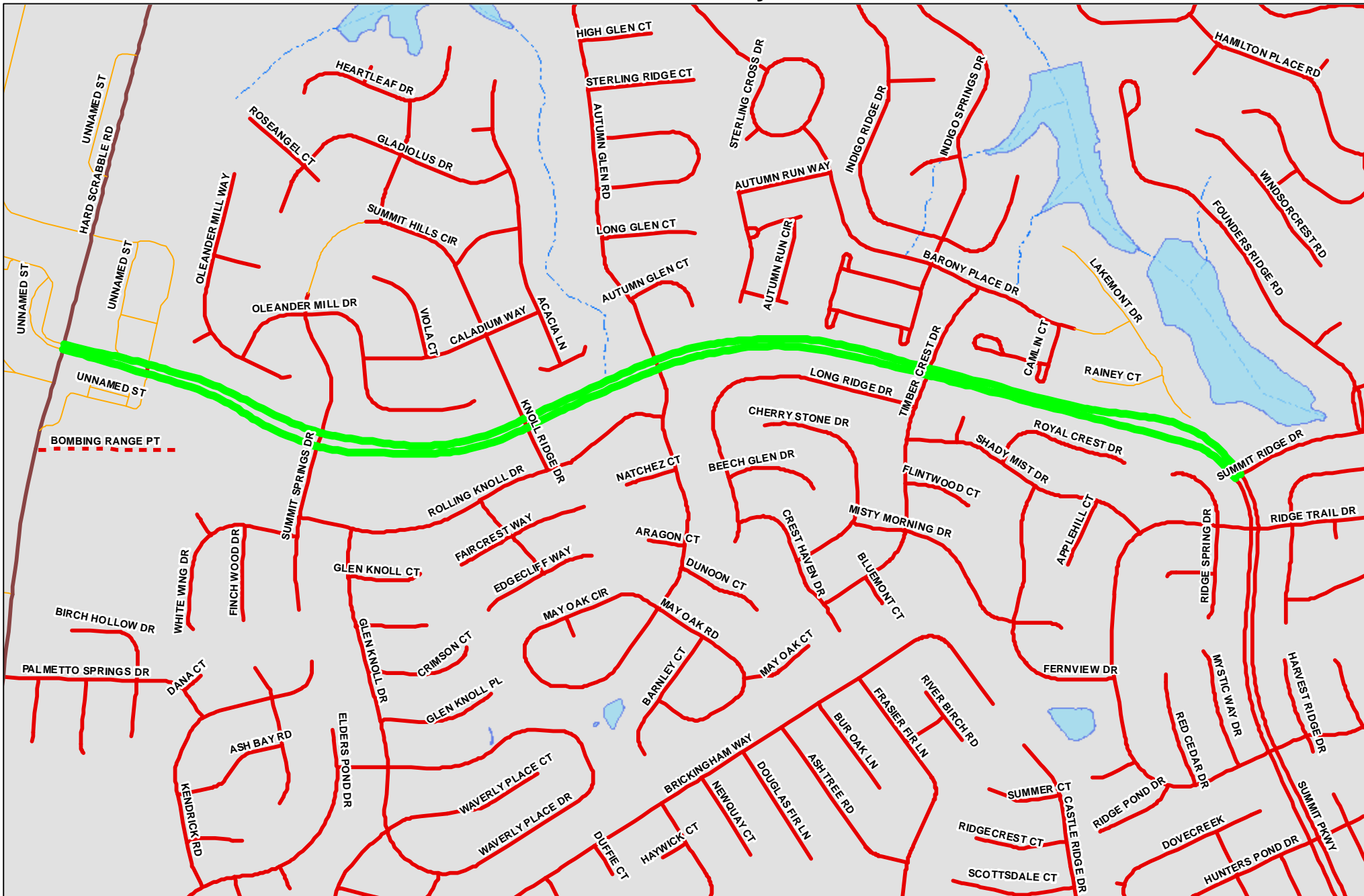

Legend

Resurfacing Project	Roads	SCDOT
Streams	Other	Interstate
	County Paved	Proposed
	County Unpaved	None
	Private / Other	

Note: Summit Pkwy Resurfacing Project.
Area between Hard Scrabble Dr & Summit Ridge Dr

1 inch = 780 feet

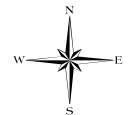

DISCLAIMER: This is a product of the Richland County Public Works Department. The data depicted here have been developed with extensive cooperation from other county departments, as well as other federal, state and local governments agencies. Reasonable efforts have been made to ensure the accuracy of this map. Richland County expressly disclaims responsibility for damages or liability that may arise from the use of this map.

PROPRIETARY INFORMATION: Any resale of this information is prohibited, except in accordance with a licensing agreement.

COPYRIGHT © 2021
Richland County Public Works
400 Powell Rd.
Columbia, SC 29205

Summit Ridge

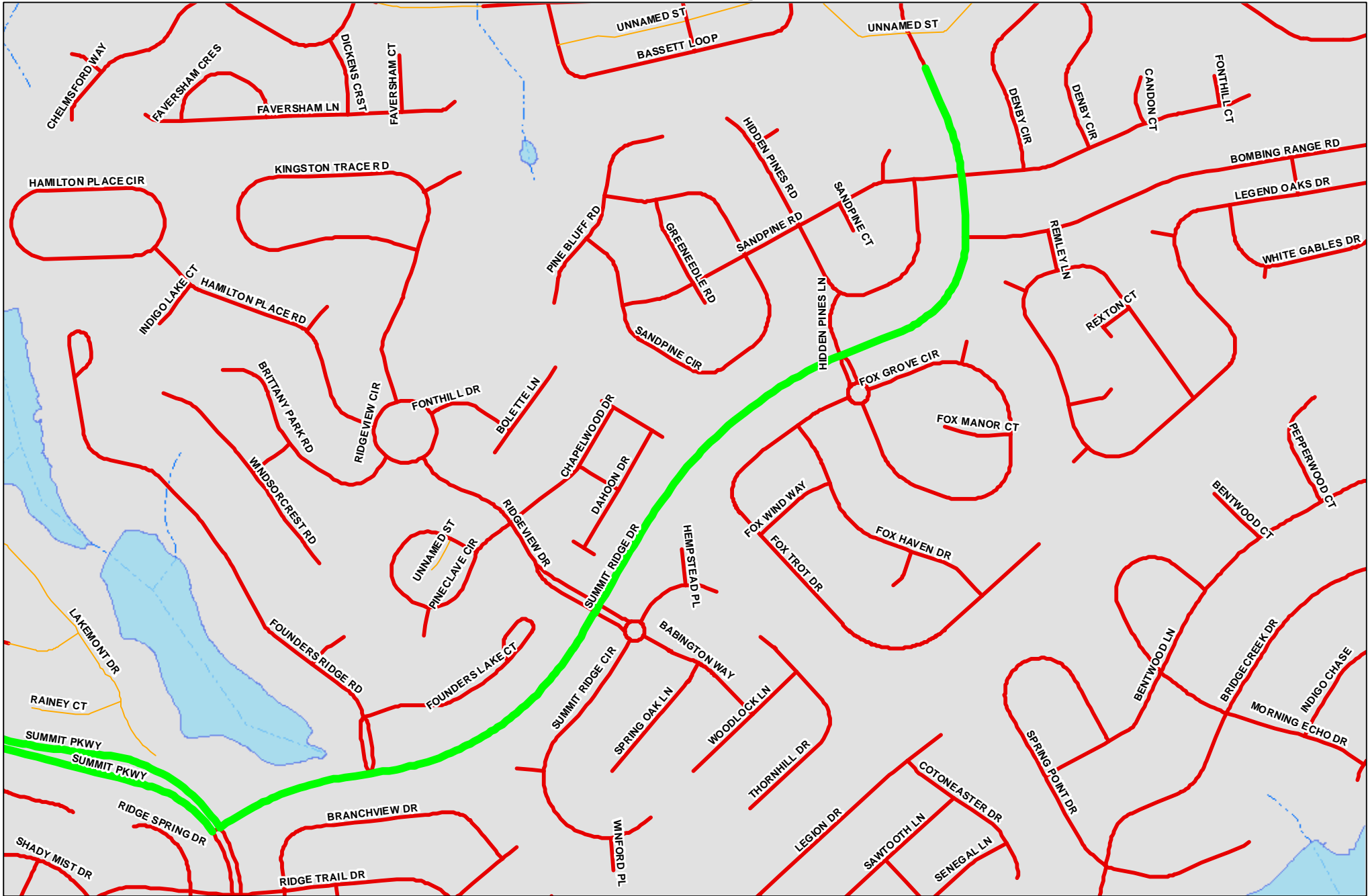

Legend

- | | | |
|---------------------|-----------------|------------|
| Resurfacing Project | Roads | SCDOT |
| Streams | Other | Interstate |
| | County Paved | Proposed |
| | County Unpaved | None |
| | Private / Other | |

Note: Summit Ridge Dr Resurfacing Project.
Area between Summit Pkwy to the entrance
to Lake Carolina Subdivision

1 inch = 620 feet

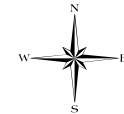

DISCLAIMER: This is a product of the Richland County Public Works Department. The data depicted here have been developed with extensive cooperation from other county departments, as well as other federal, state and local governments agencies. Reasonable efforts have been made to ensure the accuracy of this map. Richland County expressly disclaims responsibility for damages or liability that may arise from the use of this map.

PROPRIETARY INFORMATION: Any resale of this information is prohibited, except in accordance with a licensing agreement.

COPYRIGHT © 2021
Richland County Public Works
400 Powell Rd.
Columbia, SC 29203



Richland County Council Request for Action

Subject:

Utilities Department - Engineering Services for the Design and Construction of an Elevated Water Tank

Notes:

October 25, 2022 – The Administration & Finance Committee recommended Council approve the award of the design and construction for a new elevated water tank for the southeast area to AECOM.

**RICHLAND COUNTY
ADMINISTRATION**

2020 Hampton Street, Suite 4069
Columbia, SC 29204
803-576-2050



Agenda Briefing

Prepared by:	Bill Davis	Title:	Director
Department:	Utilities	Division:	
Date Prepared:	September 26, 2022	Meeting Date:	October 25, 2022
Legal Review	Tish Gonzalez via email	Date:	October 17, 2022
Budget Review	Abhijit Deshpande via email	Date:	October 10, 2022
Finance Review	Stacey Hamm via email	Date:	October 11, 2022
Approved for consideration:	Assistant County Administrator	John M. Thompson, Ph.D., MBA, CPM, SCEM	
Meeting/Committee	Administration & Finance		
Subject	Engineering Services for Design and Construction of new Elevated Water Tank for the Southeast Area		

RECOMMENDED/REQUESTED ACTION:

Staff recommends that County Council approve award of the design and construction for a new elevated water tank for the southeast area to AECOM.

Request for Council Reconsideration: Yes

FIDUCIARY:

Are funds allocated in the department’s current fiscal year budget?	<input checked="" type="checkbox"/>	Yes	<input type="checkbox"/>	No
If not, is a budget amendment necessary?	<input type="checkbox"/>	Yes	<input type="checkbox"/>	No

ADDITIONAL FISCAL/BUDGETARY MATTERS TO CONSIDER:

The cost of the engineering services for design and construction oversight is \$214,900. The funding source for the engineering services is the Utilities water system budget.

The construction cost will be funded through the American Rescue Plan (ARP) where \$2,000,000 was approved and allocated for the construction.

Applicable department/grant key and object codes: 2110367001.526500

OFFICE OF PROCUREMENT & CONTRACTING FEEDBACK:

Request for Proposal RC-533-P-23 "Engineering Services for Water Storage Tank" was issued on August 5, 2022. There were five responses to the request. An evaluation team review and scored the submittals and the highest ranked Offeror was AECOM.

COUNTY ATTORNEY’S OFFICE FEEDBACK/POSSIBLE AREA(S) OF LEGAL EXPOSURE:

The County Attorney’s Office made comments and recommendations for the proposed contract which have been incorporated.

REGULATORY COMPLIANCE:

South Carolina Department of Health and Environmental Control (SCDHEC) requires all water systems to provide adequate pressure to each customer. Currently, the existing water system experiences low

pressure in several areas when fire flow requirement is considered in the hydraulic model. At this time, there are several areas within the system that cannot be used due to low pressure.

MOTION OF ORIGIN:

"...the committee recommended allocating the American Rescue Plan funding as follows:

- Public Health -- \$15,000,000 (27.21%)
- Public Safety -- \$10,448,013 (18.95%)
- Community Investment -- \$19,000,000 (34.46%)
- Cybersecurity/Technology -- \$10,686,000 (19.38%)*"

Council Member	Coronavirus Ad Hoc Committee Recommendation
Meeting	Regular Session
Date	June 7, 2022

STRATEGIC & GENERATIVE DISCUSSION:

Utilities is requesting approval of AECOM's proposal to provide engineering services for the design and construction management of the new elevated water tank. AECOM was selected by qualifications following proper Procurement guidelines. The existing water lines are sized for future expansion to cover a large area, and the terrain is very flat; these conditions lead to some pressures lower than the 20 psi required by SCDHEC. The water tank is needed to assist with low pressure areas and to provide redundancy for the existing water tank in Hopkins, see Attachment 1 "Hopkins Water Tank." The existing tank cannot be taken down for maintenance at this time. The new tank would provide redundancy allowing us to alternatively take tanks down for cleaning and other maintenance.

The water lines constructed in the southeast were designed to provide fire flow and for future expansion of the customer base including the McEntire facility. As part of the permitting process, a portion of the existing water system had to be closed due to inadequate pressure to meet regulatory compliance when fire flow was considered. If the new tank is not constructed, the Utilities Department will not be able to add large customers like McEntire or any other customers within those areas of the system until the pressure requirements are met. Adding a new water tank would allow us to open all areas of the system.

ADDITIONAL COMMENTS FOR CONSIDERATION:

The existing Hopkins water tank cannot be out of service for maintenance due to the lack of redundancy in the existing water system. This could affect water quality and the level of service in the future. If there are any issues with the existing tank, we will not have adequate storage and will not be able to provide water to the existing customers until repairs are made. With the addition of a second tank, Utilities staff will be able to perform maintenance while utilizing the second tank for storage. Utilities staff discussed solutions for the low-pressure areas in the system with several consultants, and all agreed that having a second water tank is the best long-term solution.

ATTACHMENTS:

1. Hopkins Tank Picture
2. Scoring Summary (provided under separate cover).
3. Contract (provided under separate cover).



Uniquely Urban



Uniquely Rural

Richland County Council Request for Action

Subject:

Department of Public Works - Engineering Division - Little Jackson Creek Upditch Improvement Project

Notes:

October 25, 2022 – The Administration and Finance Committee recommended Council award a construction contract for the Little Jackson Creek Up-Ditch Drainage Project (RC-536-B-23) to North State Environmental, Inc. in the amount of \$752,077.94. The project budget shall include a contingency of \$152,409.06.

**RICHLAND COUNTY
ADMINISTRATION**

2020 Hampton Street, Suite 4069
Columbia, SC 29204
803-576-2050



Agenda Briefing

Prepared by:	Jennifer Wladischkin	Title:	Director
Department:	Office of Procurement & Contracting	Division:	
Date Prepared:	September 30, 2022	Meeting Date:	October 25, 2022
Legal Review	Patrick Wright via email	Date:	October 5, 2022
Budget Review	Abhijit Deshpande via email	Date:	October 7, 2022
Finance Review	Stacey Hamm via email	Date:	October 11, 2022
Approved for consideration:	Assistant County Administrator	John M. Thompson, Ph.D., MBA, CPM, SCEM	
Meeting/Committee	Administration & Finance		
Subject	Contract Award Recommendation - Little Jackson Creek Up-Ditch Drainage Project		

RECOMMENDED/REQUESTED ACTION:

Staff recommends approval from County Council to award a construction contract for the Little Jackson Creek Up-Ditch Drainage Project (RC-536-B-23) to North State Environmental, Inc. in the amount of \$752,077.94. The project budget shall include a contingency of \$152,409.06.

Request for Council Reconsideration: Yes

FIDUCIARY:

Are funds allocated in the department’s current fiscal year budget?	<input checked="" type="checkbox"/>	Yes	<input type="checkbox"/>	No
If not, is a budget amendment necessary?	<input type="checkbox"/>	Yes	<input checked="" type="checkbox"/>	No

ADDITIONAL FISCAL/BUDGETARY MATTERS TO CONSIDER:

This project is funded by the Hazard Mitigation Grant Program (HMGP) approved for \$904,487 with a Federal share of \$678,365 and a non-federal share of \$226,122 (25% match funded from CDBG-DR grant). Funds for this project are contained in the following keys / objects:

Applicable department/grant key and object codes: 1225992000.532200/4600164.532200
1250188000.532200/4600600.532200

OFFICE OF PROCUREMENT & CONTRACTING FEEDBACK:

Request for Bids RC-536-B-23 was issued on August 16, 2022. Six submittals were received, and after evaluation, North State Environmental Inc. was the lowest, responsive, responsible bidder.

COUNTY ATTORNEY’S OFFICE FEEDBACK/POSSIBLE AREA(S) OF LEGAL EXPOSURE:

There are no legal concerns regarding this matter.

REGULATORY COMPLIANCE:

Non-applicable.

MOTION OF ORIGIN:

There is no associated Council motion of origin.

Council Member	
Meeting	
Date	

STRATEGIC & GENERATIVE DISCUSSION:

Significant stormwater flows are conveyed into this drainage course through the up-ditch from a highly impervious watershed. Because there are no structural Best Management Practices (BMPs) in place to store and reduce flows before they enter the ditch, the water velocity causes significant erosion of the sandy soil. To address the significant erosion problem, traditional BMPs will be used such as laying back the banks, bank-toe protection/armoring, check dams, and drop structures. A Regenerative Stormwater Conveyance (RSC) will be used in the lower 1,800 feet of the up-ditch. RSCs safely convey large flows (e.g. 100-year event) over and through a step-pool sequence which creates a series of energy dissipaters that decrease downstream velocities and overall sheet stress, resulting in a reduction of downstream erosion and bank stabilization. This construction project is being funded with a Hazard Mitigation Grant (HMGP) that Richland County applied for and was approved through FEMA.

Once the project is awarded, the contractor (North State) will begin work with an estimated completion date of March 2023.

This project does not affect nor fulfill any existing ordinance. The strategic initiative for this project is to help existing Richland County residents with flooding, sediment, and erosion issues.

County Council approved, under the Blue Ribbon Committee, to proceed with the construction of this project with Hazard Mitigation Grant (HMGP) Project: FEMA-4241-DR-SC-0064-(S26) Richland County Railroad Drainage on July 11, 2017. (See Council minutes attachments)

ADDITIONAL COMMENTS FOR CONSIDERATION:

None.

ATTACHMENTS:

1. Council Regular Session Meeting minutes of July 11, 2017
2. FEMA Grant Approval Letter
3. Bid Tabulation
4. Recommendation Letter

and have used the \$63 million and the other half do not get anything. In moving forward, as is recommended, we need to stipulate that each particular project does not exceed the current estimate.

Mr. Manning accepted Mr. Malinowski's friendly amendment to stipulate that each project not exceed the current estimate.

<u>FOR</u>	<u>AGAINST</u>
Pearce	
Rose	
C. Jackson	
N. Jackson	
Malinowski	
Dickerson	
Livingston	
Kennedy	
Myers	
Manning	
McBride	

The vote in favor was unanimous.

REPORT OF THE BLUE RIBBON AD HOC COMMITTEE

- a. **Approval for submitting full applications for HMGP 4286-DR funding, with the 25% local match – Mr. Pearce stated the committee recommended approval of the full application submission and the local funding match recommendations.**

<u>FOR</u>	<u>AGAINST</u>
Pearce	
Rose	
C. Jackson	
N. Jackson	
Malinowski	
Dickerson	
Livingston	
Kennedy	
Myers	
Manning	
McBride	

The vote in favor was unanimous.

Mr. Pearce moved, seconded by N. Jackson, to reconsider this item. The motion for reconsideration failed.

- b. **Approval for the CDBG-DR Action Plan update and revision – Mr. Pearce stated the committee recommended approval of the update and revision of the County's CDBG-DR Action Plan.**

FOR

AGAINST

Pearce

Rose

C. Jackson

N. Jackson

Malinowski

Dickerson

Livingston

Kennedy

Myers

Manning

McBride

The vote in favor was unanimous.

Mr. Pearce moved, seconded by Mr. N. Jackson, to reconsider this item. The motion for reconsideration failed.

OTHER ITEMS

- a. To establish and create a Special Tax District within Richland County, South Carolina, to be known as the "Lake Dogwood Special Tax District"; to define the nature and level of services to be rendered therein; to authorize the imposition of ad valorem taxes and user service charges therein, which shall be imposed solely within the Special Tax District; to establish a commission for the tax district and provide the terms therefore; and all other matters related thereto – Mr. N. Jackson moved, seconded by Mr. Malinowski, to approve this item.

Mr. Pearce inquired if the referendum has already been held.

Mr. N. Jackson responded in the affirmative.

Mr. Pearce inquired if Council is now required to establish the tax district.

Mr. Smith stated as Council recalls they passed an ordinance authorizing these communities to conduct a referendum to establish these special tax districts. Procedurally it has to come to County Council for the referendum results to be ratified.

Mr. Pearce stated the concerns they expressed would have to be directed to the HOA.

Ms. Myers inquired if there were any guidelines established for the vote of the HOA and the manner in which it has to be taken. She stated some of the concerns voiced tonight were a little disturbing and she wanted to ensure the process that was followed by the HOA gave all of the interested parties the right, the opportunity and the notice to be heard.

Mr. Smith stated he was not familiar with this particular tax district, so he cannot speak to what was done in this case. The attorney for the HOA is present and may be able to address these questions.

Mr. C. D. Rose with the law firm of Pope Flynn. The referendum was properly noticed in accordance with State law. It was held and the vote was overwhelming in favor of the creation of the tax district. He further pointed out there were two things before Council. The first is a resolution that certifies the



U.S. Department of Homeland Security
FEMA Region IV
3003 Chamblee Tucker Road
Atlanta, GA 30341

FEMA

April 2, 2019

Mr. Kim Stenson, Director
South Carolina Emergency Management Division
2779 Fish Hatchery Road
West Columbia, SC 29172

Attention: Mr. Allen Fountain, State Hazard Mitigation Officer

Reference: Hazard Mitigation Grant Program (HMGP)
Project: **4241-0064: Richland County Railroad Drainage**

Dear Mr. Stenson:

I am pleased to inform you that the project referenced above has been approved for \$904,487 with a Federal share of \$678,365. The project's non-federal share of \$226,122 will be provided by Richland County.

The following is the approved Scope of Work (SOW) for the above referenced project (from NEMIS):

"Significant storm flow contributions are also conveyed into and through the up-ditch from a highly impervious watershed. Because there are no functional best management practices in place to store and reduce flows before they enter the ditch, the velocities and sheer stresses cause significant erosion. To address the significant erosion problem traditional best management practices will be used such as laying back the banks, bank-toe protection/armoring, check dams and drop structures. A Regenerative Stormwater Conveyance (RSC) will be used in the lower 1,500 feet of the up ditch. RSCs safely convey large flows (e.g. 100-year event) over and through a step-pool sequence, which creates a series of energy dissipaters that decrease downstream velocities and overall sheet stress, which results in a reduction of downstream erosion and bank stabilization."

FEMA will not establish activity completion timeframes for individual sub-awards. The Period of Performance (POP) of the grant award will be 36 months from the close of DR-4241's application period. This project must adhere to all HMGP program regulations, guidance, and policy, including the following conditions:

- NHPA: If human remains or intact archaeological deposits are uncovered, work near the discovery will stop immediately and all reasonable measures to avoid or minimize harm to the finds will be taken. The applicant will ensure that archaeological discoveries are secured in place, that access to the sensitive area is restricted, and that all reasonable measures are taken to avoid further

disturbance of the discoveries. The applicant's contractor will provide immediate notice of such discoveries to the applicant. The applicant shall contact the SC county sheriff or local law enforcement and FEMA within 24 hours of the discovery. Work near the discovery may not resume until FEMA has completed consultation with SHPO, Tribes, and other consulting parties as necessary. If unmarked human remains are encountered during permitted activities, all work shall stop immediately, and the proper authorities notified in accordance with South Carolina Code, Section 16-17-600.

- Any change to the approved scope of work will require re-evaluation for compliance with NEPA and other Laws and Executive Orders.
- This review does not address all federal, state and local requirements. Acceptance of federal funding requires recipient to comply with all federal, state and local laws. Failure to obtain all appropriate federal, state and local environmental permits and clearances may jeopardize federal funding.
- If ground disturbing activities occur during construction, applicant will monitor ground disturbance and if any potential archeological resources are discovered, will immediately cease construction in that area and notify the State and FEMA.

To close this project, the Governor's Authorized Representative (GAR) shall send a letter of request to close the project programmatically and financially. The letter will include the following: the date work on the project was fully completed, the date of the Recipient's final site inspection for the project, the final total project cost and Federal share, any cost underrun, a certification that reported costs were incurred in the performance of eligible work, that the approved work was completed, that the required programmatic, environmental, and any other conditions were met (including attachment of any required documentation) and that the mitigation measure is in compliance with the provisions of the FEMA-State Agreement, and this approval letter. A copy of the Recipient's final site inspection report will be enclosed with the close-out request letter. This report will contain, at minimum, all the data fields required for our HMGP final site inspection reports.

Quarterly progress reports for HMGP projects are required. Please include this HMGP project in your future quarterly reports.

The National Environmental Policy Act (NEPA) stipulates that additions or amendments to a HMGP sub-award's SOW may have to be reviewed by all State and Federal agencies participating in the NEPA process.

The State (Recipient) must obtain prior approval from FEMA before implementing changes to the approved project SOW. Per 2 CFR Part 200's Uniform Administrative Requirements:

- The Recipient must obtain prior written approval for any budget revision which would result in a need for additional federal funds.
- A change in the SOW must be approved by FEMA in advance regardless of the budget implications.
- The Recipient must notify FEMA as soon as significant developments become known, such as delays or adverse conditions that might raise costs or delay completion, or favorable conditions allowing lower cost or earlier completion.
- Any extensions of the award POP must be submitted to FEMA 60 days prior to the POP's expiration date.

The Obligation Report is enclosed for your records. Management and environmental reports are available in NEMIS. The obligated funds are available for withdrawal from **Smartlink** on sub-account number **4241DRSCP00000645**.

If you have any questions, please contact, of my staff, Carl Mickalonis of my staff at (770) 220-5628 and/or Kenya Grant at (770) 220-8893.

Sincerely,

Ernest E. Hunter

Richard S. Flood, Chief, CFM
Hazard Mitigation Assistance Branch
Mitigation Division

Enclosures

FEDERAL EMERGENCY MANAGEMENT AGENCY
HAZARD MITIGATION GRANT PROGRAM

Obligation

Disaster No	FEMA Project No	Amendment No	State Application ID	Action No	Supplemental No	State	Recipient
4241	64-R	0	47	1	61	SC	Statewide
Sub-Recipient: Richland (County)				Project Title : 26 - Richland County railroad drainage			
Sub-Recipient FIPS Code: 079-99079							

Total Amount Previously Allocated	Total Amount Previously Obligated	Total Amount Pending Obligation	Total Amount Available for New Obligation
\$678,365.25	\$678,365.25	\$0.00	\$0.00

Project Amount	Recipient Admin Est	Sub-Recipient Admin Est	Total Obligation	IFMIS Date	IFMIS Status	FY
\$678,365.25	\$0.00	\$0.00	\$678,365.25	04/04/2019	Accept	2019

Comments

Date: 04/04/2019 User Id: DBURKETT

Comment: 4241-0064-R-DR-SC-HMGP Richland (County) Application 47; 26-Richland County railroad Drainage Allocation 33 reported March S Plan Federal share \$678,365.25

Date: 04/04/2019 User Id: CMICKALO

Comment: Obligation request for project 4241-0064-R (App ID 47) Richland County Railroad Drainage; Federal Share=\$678,365. Project report 4241 March Spend Plan.

Authorization

Preparer Name: CARL MICKALONIS

Preparation Date: 04/04/2019

HMO Authorization Name: DEBORAH BURKETT

HMO Authorization Date: 04/04/2019

RC-536-B-23 Little Jackson Creek Upditch Improvements

Due: 9/26/22 2:00PM

	Cherokee, Inc.	Lindlers construction	North State Environmental	Shady Grove Construction, LLC	Shamrock Enviromental	Wiley Easton Construction Co., Inc.
Total Cost	\$1,676,715.78	\$1,272,000.00	\$752,077.94	\$ 1,643,846.0	\$806,518.40	\$1,513,498.39

September 28, 2022

Mr. David Pitts, Jr.
Richland County Stormwater General Manager
400 Powell Road
Columbia, SC 29203

**RE: Little Jackson Creek Up-Ditch Drainage Project – Re-bid
WKD Project Number 2014017.00.CL
Bid Tabulation and Recommendation of Award**

Dear Mr. Pitts:

Construction bids for the referenced project were received on September 26, 2022, at 2:00 PM. Six total bids were received by the County utilizing their Bonfire program.

We have reviewed the bid documents received from Jennifer Wladischkin on Monday, September 26, 2022. The three apparent lowest bidders, listed in ascending order, are North State Environmental Inc., Shamrock Environmental Corporation, and Lindler’s Construction of South Carolina, LLC.

During our review of the bid documents provided by Richland County, we found no math errors. However, North State Environmental had four-line items that were marked as “No Bid”. At the direction of the County WK Dickson reached out to North State Environmental Inc. about these items and it was concluded that the costs of these items were incorporated in and accounted for in other project line items. As the project will be awarded as a lump sum contract, we see no reason to disqualify their bid for this reason.

Based on the information we have received at this time; it is apparent that North State Environmental is the lowest responsive and responsible bidder.

Based on the information gathered about North State Environmental, we hereby recommend that Richland County award this Contract in the amount of \$752,077.94 to North State Environmental to perform the Little Jackson Creek Up-Ditch work. This project has received grant awards from FEMA in the amount of \$904,487. The FEMA grant award includes \$152,409.06 more than the recommended bid award which can be used as contingency funds if needed.

Mr. David Pitts
September 28, 2022
Page 2

We appreciate the opportunity to provide this service for the Richland County, and we are available to answer any questions you may have.

Sincerely,
W. K. Dickson & Co., Inc.



Lucas Funderburk, P.E.
Project Engineer

Enclosure

cc: Ms. Cynthia Kestner, Richland County
Ms. Jennifer Wladischkin, Richland County
Mr. Michael Ellison, WK Dickson
Mr. Terry Macaluso, WK Dickson

Richland County Council Request for Action

Subject:

Direct the County Administrator to look into what it will take to have Richland County CASA receive state funding to operate the way that all other CASA groups in the state do, with state funding. Richland County should not be excluded from something that is provided to all other counties by the state. [MALINOWSKI - May 3, 2022]

Notes:

October 25, 2022 – The Administration & Finance Committee recommended to direct the County Administrator to draft a fiscal impact statement.



Informational Agenda Briefing

Prepared by:	Dante Roberts	Title:	Executive Director
Department:	Court Appointed Special Advocate	Division:	
Date Prepared:	October 12, 2022	Meeting Date:	October 25, 2022
Approved for consideration:	Assistant County Administrator	John M. Thompson, Ph.D., MBA, CPM, SCCEM	
Meeting/Committee	Administration & Finance		
Subject:	Direct staff and CASA to look into what it will take to have Richland County CASA receive state funding to operate the way that all other CASA groups in the state do, with state funding. Richland County should not be excluded from something that is provided to all other counties by the state. [MALINOWSKI]		

Richland County CASA (RCCASA) joining the SC Cass Elias Guardian ad Litem Program (GAL) Program would require a legislative change to end the “Richland County Exception.” Richland County would propose and push the legislation change, but the State’s program may assist, if needed. Staff has been provided potential points of contact within the Legislature.

Per LaDara Josey, Director of the State GAL program, and Amanda Whittle, the State Child Advocate, a budget change would be required that funds full time staff, leases, cars, and other applicable equipment to support the additional county to the program. The program’s budget for the 2024 fiscal year is completed; therefore, if the matter is not urgent, the change will not occur until the 2025 fiscal year. The proposed legislation would need a fiscal impact statement which would include how many employees RCCASA has and its operational expenses to project the State allocations.

Richland County employees would be required to apply for positions when they are posted due to the entity changing from the County to State. There would not be a guarantee that current RC staff would be hired.

This process would start on July 1, 2024, and take approximately a year to complete. If the FY24 budget is amended to include RCCASA, this process could begin on July 1, 2023. Richland County would need to maintain operations during this period until a smooth transition could occur.

Staff is still awaiting additional information from Dr. Kim Jahna, Director of Richland County Delegations.

Richland County Council Request for Action

Subject:

22-006MA
Jared Munneke
GC/M-1/RU/RM-HD to RM-HD (74.28 Acres)
End of Idlewilde Boulevard and Barnes Street
TMS# R11111-01-02, 54 & 55, R11114-01-02 & 13

Notes:

First Reading: September 27, 2022
Second Reading: October 18, 2022
Third Reading: November 1, 2022 {Tentative}
Public Hearing: September 27, 2022

STATE OF SOUTH CAROLINA
COUNTY COUNCIL OF RICHLAND COUNTY
ORDINANCE NO. ____-22HR

AN ORDINANCE OF THE COUNTY COUNCIL OF RICHLAND COUNTY, SOUTH CAROLINA, AMENDING THE ZONING MAP OF UNINCORPORATED RICHLAND COUNTY, SOUTH CAROLINA, TO CHANGE THE ZONING DESIGNATION FOR THE REAL PROPERTY DESCRIBED AS TMS # R11111-01-02, R11111-01-54, R11111-01-55, R11114-01-02, R11114-01-13 FROM GENERAL COMMERCIAL DISTRICT (GC), LIGHT INDUSTRIAL DISTRICT (M-1), RURAL DISTRICT (RU), AND RESIDENTIAL MULTI-FAMILY HIGH DENSITY DISTRICT (RM-HD) TO RESIDENTIAL MULTI-FAMILY MEDIUM DENSITY DISTRICT (RM-MD); AND PROVIDING FOR SEVERABILITY AND AN EFFECTIVE DATE.

Pursuant to the authority granted by the Constitution of the State of South Carolina and the General Assembly of the State of South Carolina, BE IT ENACTED BY RICHLAND COUNTY COUNCIL:

Section I. The Zoning Map of unincorporated Richland County is hereby amended to change the real property described as TMS # R11111-01-02, R11111-01-54, R11111-01-55, R11114-01-02, R11114-01-13 from General Commercial District (GC), Light Industrial District (M-1), Rural District (RU), and Residential Multi-Family High Density District (RM-HD) to Residential Multi-Family Medium Density District (RM-MD).

Section II. Severability. If any section, subsection, or clause of this Ordinance shall be deemed to be unconstitutional, or otherwise invalid, the validity of the remaining sections, subsections, and clauses shall not be affected thereby.

Section III. Conflicting Ordinances Repealed. All ordinances or parts of ordinances in conflict with the provisions of this ordinance are hereby repealed.

Section IV. Effective Date. This ordinance shall be effective from and after _____, 2022.

RICHLAND COUNTY COUNCIL

By: _____
Overture Walker, Chair

Attest this _____ day of
_____, 2022

Anette A. Kirylo
Clerk of Council

RICHLAND COUNTY ATTORNEY'S OFFICE

Approved As To LEGAL Form Only.
No Opinion Rendered As To Content.

Public Hearing: September 27, 2022
First Reading: September 27, 2022
Second Reading: October 4, 2022
Third Reading: October 18, 2022

Richland County Council Request for Action

Subject:

Developing a multi-county park with Fairfield County; authorizing the execution and delivery of an agreement governing the multi-county park; authorizing the inclusion of certain property located in Richland County in the multi-county park; authorizing the execution of an intergovernmental agreement; and other related matters

Notes:

First Reading: October 4, 2022

Second Reading: October 18, 2022

Third Reading: November 1, 2022 {Tentative}

Public Hearing: November 1, 2022

STATE OF SOUTH CAROLINA
COUNTY COUNCIL FOR RICHLAND COUNTY
ORDINANCE NO. _____

DEVELOPING A MULTI-COUNTY PARK WITH FAIRFIELD COUNTY; AUTHORIZING THE EXECUTION AND DELIVERY OF AN AGREEMENT GOVERNING THE MULTI-COUNTY PARK; AUTHORIZING THE INCLUSION OF CERTAIN PROPERTY LOCATED IN RICHLAND COUNTY IN THE MULTI-COUNTY PARK; AUTHORIZING THE EXECUTION OF AN INTERGOVERNMENTAL AGREEMENT; AND OTHER RELATED MATTERS.

WHEREAS, an economic development project previously known as Project Bulldog (“Project”) desires to redevelop the Richland Fashion Mall site and surrounding areas (collectively, “Site”) located in the City of Forest Acres (“City”) in Richland County, South Carolina (“Richland County”); and

WHEREAS, it is expected that the Project will increase the tax base of Richland County, encourage additional investment in taxable real and personal property and job creation in the City and Richland County, and remove and transform vacant commercial property;

WHEREAS, in consideration of these anticipated benefits, SE Forest Acres, LLC, the company which will undertake the Project (“Company”), has negotiated for certain infrastructure credits (“Credits”) with Richland County to pay costs of, among other things, designing, acquiring, constructing, improving or expanding the infrastructure serving the Project and for improved and unimproved real estate and personal property (collectively, “Infrastructure”) at the Site; and

WHEREAS, Richland County desires to locate the real and personal property comprising the Site (collectively, “Property”) in a multicounty industrial or business park (“Park”) in order to provide the Credits to the Company for the Infrastructure pursuant to § 4-1-175 of the Code of Laws of South Carolina, 1976, as amended;

WHEREAS, Richland County and Fairfield County, South Carolina (“Fairfield County” and together with Richland County, the “Counties”) are authorized pursuant to Article VIII, Section 13 of the Constitution and in accordance with §4-1-170, Code of Laws of South Carolina, 1976, as amended, to jointly develop an industrial or business park within the geographical boundaries of one or both of the member Counties; and

WHEREAS, the Counties desire to jointly develop the Park by executing and delivering the “Master Agreement Governing the Richland Mall Business Park,” the substantially final form of which is attached as Exhibit A (“Master Agreement”) and, with the consent of the City, locate the Property in the Park; and

WHEREAS, the provisions of the Master Agreement will govern the operation of the Park, including the sharing of expenses and revenues of the Park, and the manner in which the revenue is to be distributed to each of the taxing entities within each of the Counties; and

WHEREAS, in connection with the Project and the development of the Park, Richland County and the City desire to enter into an Intergovernmental Agreement, the substantially final form of which is attached as Exhibit B (“Intergovernmental Agreement”).

NOW, THEREFORE, BE IT ORDAINED BY THE RICHLAND COUNTY COUNCIL:

Section 1. *Development of Park; Execution of Master Agreement.* Richland County is authorized to jointly develop the Park with Fairfield County. The Richland County Council Chair (“Chair”) is authorized to execute the Master Agreement, the Clerk to the Richland County Council (“Clerk”) is authorized to attest the same, and the Richland County Administrator (“Administrator”) is authorized to deliver the Master Agreement to Fairfield County. The form and terms of the Master Agreement are approved, with any revisions that are not materially adverse to Richland County and are approved by the Administrator after consultation with legal counsel to Richland County.

Section 2. *Inclusion of Property.* The Park’s boundaries shall include the Property. The Chair and the Administrator are hereby authorized to take such further actions as may be necessary to include the Property in the Park’s boundaries. Pursuant to the terms of the Master Agreement, the location of the Property in the Park is complete upon (i) the enactment of this Ordinance by the Richland County Council and a companion ordinance by the Fairfield County Council and (ii) the delivery by Richland County of a description of the Property to Fairfield County.

Section 3. *Intergovernmental Agreement.* Richland County is authorized to enter into the Intergovernmental Agreement with the City. The Chair is authorized to execute the Intergovernmental Agreement, the Clerk is authorized to attest the same, and the Administrator is authorized to deliver the Intergovernmental Agreement to the City. The form and terms of the Intergovernmental Agreement are approved, with any revisions that are not materially adverse to Richland County and are approved by the Administrator after consultation with legal counsel to Richland County.

Section 4. *Further Assurances.* The Chair and the Administrator (or their respective designees) are authorized to execute whatever other documents and take whatever further actions as may be necessary to effect this Ordinance.

Section 5. *Severability.* If any part of this Ordinance is unenforceable, the remainder is unaffected.

Section 6. *General Repealer.* Any ordinance, resolution or order, the terms of which conflict with this Ordinance, is, only to the extent of that conflict, repealed.

Section 7. *Effective Date.* This Ordinance is effective after third and final reading.

RICHLAND COUNTY, SOUTH CAROLINA

Chairman of County Council
Richland County, South Carolina

(SEAL)

ATTEST:

Clerk to County Council
Richland County, South Carolina

READINGS:

First Reading: October 6, 2022
Second Reading: October 18, 2022
Public Hearing: November 1, 2022
Third Reading: November 1, 2022

EXHIBIT A
FORM OF MASTER AGREEMENT

MASTER AGREEMENT
GOVERNING THE
RICHLAND MALL BUSINESS PARK

BETWEEN

RICHLAND COUNTY, SOUTH CAROLINA

AND

FAIRFIELD COUNTY, SOUTH CAROLINA

EFFECTIVE AS OF

[], 2022

PREPARED BY:

PARKER POE ADAMS & BERNSTEIN LLP
1221 MAIN STREET, SUITE 1100
COLUMBIA, SOUTH CAROLINA 29201
803.255.8000

**INSTRUCTIONS
FOR
COUNTY AUDITOR AND COUNTY TREASURER**

ALL PROPERTY LOCATED IN THIS MULTI-COUNTY INDUSTRIAL/BUSINESS PARK (THE "PARK") IS EXEMPT FROM *AD VALOREM* TAXES AND IS SUBJECT INSTEAD, UNDER THE TERMS OF THE STATE CONSTITUTION, TO A NON-NEGOTIATED FEE-IN-LIEU OF *AD VALOREM* TAXES EQUAL TO WHAT THE TAXES WOULD HAVE BEEN, BUT FOR THE EXISTENCE OF THE PARK. HOWEVER, THE FEE-IN-LIEU PAYMENTS FOR PARK PROPERTY MAY BE BELOW NORMAL *AD VALOREM* TAX RATES IF THE PROPERTY IS SUBJECT TO A NEGOTIATED FEE-IN-LIEU OF TAXES ARRANGEMENT ("FILOT") OR SPECIAL SOURCE REVENUE CREDIT ("SSRC"). WHEN PREPARING THE FEE BILLS FOR ALL PROPERTY LOCATED IN THIS PARK, PLEASE REFERENCE ALL RECORDS FOR PARK PROPERTY, INCLUDING, WITHOUT LIMITATION, THE FILOT AND SSRC RECORDS TO ENSURE THE CORRECT MILLAGE RATE AND ASSESSMENT RATIO ARE USED, OR TO DETERMINE ANY APPLICABLE SSRC.

ONCE A FEE BILL FOR PARK PROPERTY HAS BEEN PAID TO A COUNTY, THE PROVISIONS OF THIS AGREEMENT GOVERN HOW THE FEE PAYMENT IS TO BE DISTRIBUTED BETWEEN THE COUNTIES AND THEN AMONG THE VARIOUS TAXING ENTITIES IN EACH COUNTY. EACH COUNTY MAY ALTER THE CUSTOMARY DISTRIBUTION OF REVENUES WITHIN THAT COUNTY, AND MAY CHANGE THE DISTRIBUTION STATED HEREIN WITHIN THAT COUNTY, BUT DISTRIBUTION BETWEEN THE COUNTIES AS STATED HEREIN CAN ONLY BE CHANGED BY AMENDMENT OF THIS AGREEMENT.

THIS MASTER AGREEMENT (“Agreement”), effective as of []. 2022 (“Effective Date”), between Richland County, South Carolina (“Richland County”), a political subdivision of the State of South Carolina (“State”), and Fairfield County, South Carolina (“Fairfield County” and together with Richland County, the “Counties” or, each, a “County”), a political subdivision of the State is entered into pursuant to Article VIII, Section 13(D) of the South Carolina Constitution, as amended, and South Carolina Code Annotated Section 4-1-170 (collectively, the “MCIP Law”).

RECITALS:

WHEREAS, the Counties are permitted by the MCIP Law to create one or more multi-county industrial or business parks;

WHEREAS, as provided under MCIP Law, to promote the economic welfare of their citizens by encouraging new and expanding industrial or commercial development to locate in the Counties, thereby expanding the Counties’ tax base and creating opportunities for investment in taxable real and personal property and job creation, the Counties desire to jointly develop the “Richland Mall Business Park” (“Park”);

WHEREAS, by Richland Ordinance No. [] and Fairfield Ordinance No. [], the Counties authorized the creation of the Park, the location of certain property in the Park, and the execution of this Agreement to govern the operation of the Park, including the sharing of expenses and revenues of the Park and the manner in which the revenue is to be distributed to each of the taxing entities within each County; and

WHEREAS, because property located in the Park is geographically situated in the City of Forest Acres, South Carolina (“City”), the Counties have obtained the consent of the City prior to the creation of the Park, as evidenced by the City’s acknowledgment to this Agreement.

NOW, THEREFORE, on the basis of the mutual covenants in this Agreement, the sufficiency of which consideration the Counties acknowledge, the Counties agree:

**ARTICLE I
PARK BOUNDARIES**

Section 1.01. Park Boundaries.

(a) The Park consists of the real property described on Exhibit A and all improvements or personal property located thereon (collectively, “Property”).

(b) To enlarge the boundaries of the Park, the County in which the real or personal property to be included in the Park is located (“Host County”) shall adopt a resolution or ordinance authorizing the inclusion of such additional property in the Park. Upon such action, this Agreement will be automatically amended to reflect the enlargement of the Park’s boundaries without further action by the governing bodies of either County on delivery of written notice to the non-Host County (“Companion County”) of the inclusion of the additional real or personal property in the Park. The written notice shall include a copy of the resolution or ordinance approving the inclusion of the property in the Park and a description or identification of the property included in the Park.

(c) The Counties may diminish the boundaries of the Park from time to time to remove real or personal property from the Park. To diminish the boundaries of the Park, the Host County and the Companion County shall each adopt a resolution or ordinance authorizing the removal of property from the Park. Upon such action, this Agreement will be automatically amended to reflect the diminishment of the Park’s boundaries once each County has adopted its approving resolution or ordinance. Each County

shall deliver a copy of its resolution or ordinance approving the diminishment of the boundaries of the Park to the other County.

(d) In the event of any addition or diminishment under Section 1.01(b) or (c), respectively, Exhibit A shall be updated and supplemented to reflect such change.

ARTICLE II TAX STATUS OF PROPERTIES LOCATED IN THE PARK

Section 2.01. Constitutional Exemption from Taxation. Under the MCIP Law, so long as the Property is located in the Park, the Property is exempt from all *ad valorem* taxation. The Property shall be deemed as located in the Park so long as this Agreement is effective.

Section 2.02. Park Fee-in-Lieu of Taxes. Except as provided in Section 2.03, the owners or lessees of Property shall pay an amount equivalent to the *ad valorem* property taxes or other in lieu of payments that would have been due and payable but for the location of Property in the Park.

Section 2.03. Negotiated Fee-in-Lieu of Taxes. The amount of the annual payments due from the owner or lessee under Section 2.02 may be altered by virtue of any negotiated incentive with either County, including a negotiated fee-in-lieu of *ad valorem* taxes incentive or infrastructure credit as provided in Sections 12-44-10, et seq., 4-1-175, 4-12-30, or 4-29-67 of the Code of Laws of South Carolina 1976, as amended, or any successor or similar provisions thereto as may be provided under State law (collectively the revenues described in Sections 2.02 and 2.03 are referred to herein as the, “FILOT Revenue”).

ARTICLE III SHARING OF FILOT REVENUE AND EXPENSES OF THE PARK

Section 3.01. Expense Sharing. The Counties shall share all expenses related to the Park. If the Property is located in Richland County, then Richland County shall bear 100% of the expenses. If the Property is located in Fairfield County, then Fairfield County shall bear 100% of the expenses. Notwithstanding the foregoing, if any Property is privately-owned, the owner or developer of such Property can be required to bear 100% of the expenses related to that Property in the Park on behalf of the Host County.

Section 3.02. FILOT Revenue Sharing.

(a) For revenue generated in the Park from a source other than FILOT Revenue, the County in which the revenue is generated may retain such revenue, to be expended in any manner as that County deems appropriate and is in accordance with State law.

(b) Commencing with tax year [2022], the Counties shall share all FILOT Revenue according to the following distribution method:

(i) For Property located in Richland County: Richland County, after making any reductions required by law or other agreement and reimbursing itself for expenditures made to attract to and locate Property in the Park, shall retain 99% of the remaining FILOT Revenue (the “Residual FILOT Revenue”) and transmit 1% of the Residual FILOT Revenue to Fairfield County in accordance with Section 3.04.

(ii) For Property located in Fairfield County: Fairfield County, after making any reductions required by law or other agreement and reimbursing itself for expenditures made to attract to and locate

Property in the Park, shall retain 99% of the Residual FILOT Revenue and transmit 1% of the Residual FILOT Revenue to Richland County in accordance with Section 3.04.

Section 3.03. FILOT Revenue Distribution in Each County.

(a) Commencing with tax year [2022], after sharing of the Residual FILOT Revenue as provided by Section 3.02(b):

(i) For Property located in Richland County, the Residual FILOT Revenue retained by Richland County shall be distributed within Richland County as follows:

FIRST 7% shall be deposited to the Richland County Industrial Park Fund (“Fund”); and

SECOND the remainder of the Residual FILOT Revenue shall be distributed, on a pro rata basis according to the millage that the taxing entities, including Richland County, would otherwise, at the time Property is included in the Park, be eligible to levy millage on the Property if such property were not located in the Park. Any Residual FILOT Revenue distributed to a school district pursuant to the foregoing sentence shall be further divided on a pro rata basis according to the operating and debt service millage levied by or collected on behalf of the school district.

(ii) For Property located in Fairfield County, the Residual FILOT Revenue retained by Fairfield County shall be distributed on a pro rata basis according to the millage that the taxing entities, including Fairfield County, would levy on the Property in the tax year in which such Residual FILOT Revenue is received had the Property not been located in the Park. Any Residual FILOT Revenue distributed to a school district pursuant to the foregoing sentence shall be further divided on a pro rata basis according to the operational and debt service millage levied by or collected on behalf of the school district.

(b) Each County elects to retain 100% of the 1% of the Residual FILOT Revenue received from the other County as provided in Section 3.02(b). Richland County further elects to deposit such Residual FILOT Revenue in the Fund.

(c) Each County, by enactment of an ordinance in that County, may unilaterally amend its internal distribution method of any Residual FILOT Revenue that it retains or receives. This Agreement will be automatically amended to reflect the amendment to the distribution scheme without further action by the governing bodies of either County on delivery of written notice to the Companion County of the amendment. The written notice shall include a copy of the ordinance approving the amendment.

Section 3.04. Annual Report and Disbursement. Not later than July 15 of each year, starting July 15 of the first year in which either County receives FILOT Revenue, each County shall prepare and submit to the other County a report detailing the FILOT Revenue owed under this Agreement. Each County shall deliver a check for the amount reflected in that report at the same time to the other County.

**ARTICLE IV
MISCELLANEOUS**

Section 4.01. Jobs Tax Credit Enhancement. Business enterprises locating in the Park are entitled to whatever enhancement of the regular jobs tax credits authorized by South Carolina Code Annotated Section 12-6-3360, or any successive provisions, as may be provided under South Carolina law.

Section 4.02. Assessed Valuation. For the purpose of bonded indebtedness limitation and computing the index of taxpaying ability pursuant to South Carolina Code Annotated Section 59-20-20(3), allocation of the assessed value of Property to each County is identical to the percentage of FILOT Revenue retained and received by each County in the preceding fiscal year.

Section 4.03. Records. Each County shall, at the other County's request, provide a copy of each record of the annual tax levy and the fee-in-lieu of *ad valorem* tax invoice for the Property and a copy of the applicable County Treasurer's collection records for the fee-in-lieu of *ad valorem* taxes so imposed, as these records became available in the normal course of each County's procedures.

Section 4.04. Applicable Law. To avoid any conflict of laws between the Counties, the county law of the County in which a parcel of Property is located is the reference for regulation of that parcel of Property in the Park. Nothing in this Agreement purports to supersede State or federal law or regulation. The County in which a parcel of Property is located is permitted to adopt restrictive covenants and land use requirements for that part of the Park.

Section 4.05. Law Enforcement. The Sheriff's Department for the County in which a parcel of Property is located has initial jurisdiction to make arrests and exercise all authority and power with respect to that parcel; fire, sewer, water and EMS service for each parcel of Property in the Park is provided by the applicable service district or other political unit in the applicable County in which that Property is located.

Section 4.06. Binding Effect of Agreement. This Agreement is binding after execution by both of the Counties is completed.

Section 4.07. Severability. If (and only to the extent) that any part of this Agreement is unenforceable, then that portion of the Agreement is severed from the Agreement and the remainder of this Agreement is unaffected.

Section 4.08. Complete Agreement: Amendment. This Agreement is the entire agreement between the Counties with respect to this subject matter and supersedes all agreements, representations, warranties, statements, promises and understandings, whether oral or written, with respect to the Park and the Property therein and neither County is bound by any oral or written agreements, statements, promises, or understandings not set forth in this Agreement.

Section 4.09. Counterpart Execution. The Counties may execute this Agreement in multiple counterparts, all of which, together, constitute but one and the same document.

Section 4.10. Termination. Notwithstanding any part of this Agreement to the contrary, this Agreement terminates automatically on the earlier of (a) the termination of the Infrastructure Credit Agreement between Richland County and SE Forest Acres, LLC or (b) 20 years following the Effective Date.

[Signatures follow]

IN WITNESS WHEREOF, the Counties have each executed this Agreement, effective on the Effective Date.

RICHLAND COUNTY, SOUTH CAROLINA

By: _____
Chairman of County Council

(SEAL)
ATTEST:

Clerk to County Council

FAIRFIELD COUNTY, SOUTH CAROLINA

By: _____
Chairman of County Council

(SEAL)
ATTEST:

Clerk of County Council

**ACKNOWLEDGED AND CONSENTED TO BY
THE CITY OF FOREST ACRES, SOUTH CAROLINA:**

City Administrator

(SIGNATURE PAGE)

EXHIBIT A
LEGAL DESCRIPTION OF THE PROPERTY

[AS MAY BE UPDATED ACCORDING TO ARTICLE I OF THE AGREEMENT]

THE LAND REFERRED TO HEREIN BELOW IS SITUATED IN THE COUNTY OF RICHLAND, STATE OF SOUTH CAROLINA AND IS DESCRIBED AS FOLLOWS:

ALL THAT CERTAIN tract of land, with all improvements thereon, situate in the Town of Forest Acres, Richland County, South Carolina, containing 32.9393 Acres as shown on a ALTA/ACSM Land Title Survey Prepared for JTL Capital, LLC by Steadman & Associates, Inc., dated October 2, 2002, revised December 13, 2002, recorded in the Office of the Register of Deeds for Richland County in Book 739 at Page 10, said plat being incorporated herein by reference, said property being more particularly described as follows:

BEGINNING at a point designated as "POB", said point being a PK nail along the western margin of the right-of-way of Beltline Boulevard (S.C. Highway No. 16) where the subject property corners with property of Colt Site 12 Inc. a distance of 165.15 feet from the intersection of Beltline Boulevard with the southern margin of the right-of-way of Forest Drive (S.C. Highway No. 12) and running along Beltline Boulevard as follows: in a curve to the right having a radius of 141.03 feet, an arc distance of 38.64 feet, the chord of which runs S 06-00-05 W, 38.52 feet to a rebar; S76-30-04 E, 29.01 feet to an "X" in concrete S 24-20-15 E, 66.01 feet to a PK nail; S 20-58-56 W, 29.14 feet to a rebar; in a curve to the right have a radius of 33.77 feet, an arc distance of 22.47 feet, the chord of which runs S 49-48-51 E, 22.06 feet to a PK nail; S 27-51-15 E, 103.05 feet to a rebar; S 28-34-06 E, 516.43 feet to a rebar; in a curve to the right having a radius of 52.17 feet, an arc distance of 35.19 feet, the chord of which runs S 48-47-02 E, 34.53 feet to a rebar; S28-43-30 E, 131.12 feet to a rebar; S 21-53-30 E, 101.50 feet to a rebar; S 31-13-04 E, 149.1 1 feet to a rebar; S 31-45-00 E, 19.48 feet to a rebar; S 40-50-56 E, 84.66 feet to a PK nail; S 40-56-04 E, 109.70 feet to a rebar; thence turning and running along property of Woodland Village Apartments S 42-18-17 W, 285.91 feet to a rebar; thence turning and running along property of Diane R. Spearman as follows: N 59-24-55 W, 186.52 feet to a rebar; N 64-17-05 W, 51.76 feet to an open top; S 03-25-35 E, 104.94 feet to an open top; thence turning and running along Brookwood Court S 85-00-43 W, 65.00 feet to a calculated point; thence turning and running along property of McQueen Smith as follows: N04-44-57 W, 120.00 feet to an open top; N 53-20-55 W, 66.63 feet to an open top; S 63-51-41 W, 73.18 feet to a pinch top; thence turning and running along property of Scott L. Whelchel & Dana H. Whelchel N 26-02-32 W, 65.25 feet to an open top; thence turning and running along property of David B. Tate as follows: N 26-28-42 W, 65.03 feet to a rebar; N-26-29-46 W, 64.72 feet to a calculated point in concrete; S 63-33-42 W, 150.00 feet to a rebar; thence turning and running along Colin Kelly Drive as follows: N 25-26-03 W, 280.00 feet to a rebar; in a curve to the left having a radius of 223.79 feet, an arc distance of 77.04 feet, the chord of which runs N 52-37-33 W, 76.66 feet to a rebar; in a curve to the left having a radius of 223.79 feet, an arc distance of 77.05 feet, the chord of which runs S 87-56-06 W, 76.67 feet to a rebar; S 63-34-32 W, 250.47 feet to an open top; thence turning and running along McArthur Avenue N 26-18-28 W, 70.15 feet to a rebar; thence turning and running along the terminus of McArthur Avenue and along property of Paula R. Bunt S63-46-47 W, 199.92 feet to an open top; thence turning and running along property of Sunnyside Properties, Inc. as follows: N 26-38-48 W, 102.35 feet to an open top; N 26-31-13 W, 77.43 feet to an open top; thence turning and continuing along property of Sunnyside Properties, Inc. and along property of Claiborne E. Reeder & Nancy P. Reeder N 25-58-44 W, 60.13 feet to an open top; thence turning and continuing along property of Claiborne E. Reeder & Nancy P. Reeder and along properties of C.E. Reeder & Nancy P. Reeder, Robert G. Cook & Robin D. Anderon, George L. Bryant, Catherine H. Bradley, Martha Diaz, and Joseph M. Diaz & Martha Diaz N 26-15-04 W, 324.64 feet to an open top; thence turning and running along property of Sharon Kay Ford as follows: N 63-38-18 E, 52.16 feet to an open top; N 76-42-51 W, 78.96 feet to an open top; thence turning and running along properties of Martha Diaz and Lorraine M. Tablas N 25-58-03 W, 103.51 feet to a rebar, thence turning and continuing along property of Lorraine M. Tablas S 63-34-24 W, 53.87 feet to a rebar; thence turning and running along property of Buckner Associates A Partnership as follows: N 26-38-33 W, 87.35 feet to a rebar; S 68-31-11 W, 30.08 feet

to a pinch top; thence turning and running along property of Carolina Associates, A S.C. Partnership N 26-31-33 W, 79.43 feet to an open top; thence turning and running along Forest Drive N 68-21-02 E, 95.19 feet to a rebar; thence turning and running along property of Olin W. Hollis, Jr. as follows: S 09-42-05 E, 31.88 feet to a PK nail; in a curve to the left having a radius of 100.00 feet, an arc distance of 84.59 feet, the chord of which runs S 35-10-53 E, 82.09 feet to a PK nail; S 58-09-49 E, 36.04 feet to a rebar; N 44-44-46 E, 164.97 feet to a magnetic nail; N 36-34-36 W, 59.14 feet to an "X" in concrete; thence turning and running along Forest Drive as follows: N 68-16-41 E, 594.92 feet to a rebar; in a curve to the right having a radius of 92.93 feet, an arc distance of 44.96 feet, the chord of which runs N81-57-26 E, 44.52 feet to a rebar; N 09-2743 E, 23.9 feet to an "X" cut in concrete; N 69-11-44 E, 140.34 feet to a rebar; S 46-09-12 E, 29.02 feet to a rebar; in a curve to the right having a radius of 89.22 feet, an arc distance of 55.43 feet, the chord of which runs N 60-56-39 E, 54.54 feet to a rebar; N78-48-08 E, 17.00 feet to a calculated point in grate; thence turning and running along property of Colt Site 12 Inc. as follows: S 16-47-13 E, 165.96 feet to a rebar; N 77-22-02 E, 169.17 feet to the POINT OF BEGINNING.

LESS AND EXCEPT: "TGI Friday's Parcel"

ALL THAT CERTAIN piece, parcel or tract of land, with all improvements thereon, situate, lying and being in the County of Richland, State of South Carolina, containing 0.143 acres, according to a plat of survey entitled "Boundary Survey of Richland Mall TGI Friday's", prepared by B. P. Barber & Associates, Inc., dated March 19, 2005 and recorded on April 19, 2005 in the Office of the Register of Deeds for Richland County in Book 1044 at Page 323. Reference to said plat is hereby made for a metes and bounds description thereof.

LESS AND EXCEPT: "Verizon Wireless Parcel"

ALSO: ALL THAT CERTAIN piece, parcel or tract of land, with all improvements thereon, situate, lying and being in the County of Richland, State of South Carolina, containing 9.391 acres, according to a plat of survey entitled "Boundary Survey for Richland Mall Verizon Wireless", prepared by B. P. Barber & Associates, Inc., dated April 4, 2005, last revised June 7, 2005, and recorded on June 14, 2005 in the Office of the Register of Deeds for Richland County in Book 1063 at Page 652. Reference to said plat is hereby made for a metes and bounds description thereof.

LESS AND EXCEPT: "Bank of America Parcel"

ALL THAT CERTAIN piece, parcel, or tract of land, with all improvements thereon, situate, lying and being in the County of Richland, State of South Carolina, containing 0.77 acres, according to a plat of survey entitled "Plat Prepared for Windsor Richland Mall, L.P., a Texas Limited Partnership", prepared by Baxter Land Surveying Co., Inc., dated February 11, 2003, and recorded on February 28, 2005 in the Office of the Register of Deeds for Richland County in Book 1027 at Page 2697. Reference to said plat is hereby made for a metes and bounds description thereof.

TMS Nos.: R13908-04-35; R14001-11-11; and R14005-08-002 (for informational purposes only)

AND ALSO

THE LAND REFERRED TO HEREIN BELOW IS SITUATED IN THE COUNTY OF RICHLAND, STATE OF SOUTH CAROLINA AND IS DESCRIBED AS FOLLOWS:

PARCEL 1 (VERIZON WIRELESS PARCEL)

All that certain piece, parcel or of land with the improvements thereon, situate, lying and being in the County of Richland, State of South Carolina; the same being shown as 9.391 acres on a Boundary Survey of Richland Mall Verizon Wireless for Windsor Richland Mall, Limited Partnership by B.P. Barber & Associates, Inc. dated April 4, 2005, revised April 16, 2005, last revised June 7, 2005 and recorded in the Office of the Register of Deeds for Richland County on June 14, 2005 in Book 1063 at page 652.

PARCEL 2 (EASEMENT PARCEL)

Together with rights under the Reciprocal Easement, Covenant, Operation and Restriction Agreement and Declaration dated September 7, 2005 by and between BRC Richland, LLC, a Georgia liability company and Windsor Richland Mall, L.P., a Texas limited partnership, to be recorded, and being more particularly as:

That certain tract of land, with improvements thereon, situate, in the Town of Forest Acres, Richland County, South Carolina, containing 32.9393 acres as shown on ALTA/ACSM Land Title Survey prepared for JTL Capital, LLC by Steadman & Associates, Inc. dated October 3, 2002, revised December 13, 2002, in the Office of the Register for Richland County in Book 739 at page 10, said plat being incorporated herein by reference, said property being more particularly described as follows:

BEGINNING at a point designated as "POB", point being PK nail along the western margin of the right-of-way of Beltline Boulevard (SC. Highway No. 16) where the subject property corners with property of Colt Site 12 Inc. a distance of 165.15 feet from the intersection of Beltline Boulevard with the southern margin of the right-of-way of Forest Drive (SC Highway No. 12) and running along Beltline Boulevard as follows: in a curve to the right having a radius of 141.03 feet, an arc distance of 38.64 feet, the chord of which runs S06°00'05"W - 38.52 feet to a rebar, S76°30'04"E - 29.01 feet to an "X" in concrete; S24°20'15"E - 66.01 feet to a PK nail; S20°58'56"W - 29.14 to a rebar; in a curve to the right have radius of 33.77 feet, an arc distance of 22.47 feet, the chord of which runs S49°48'51"E - 22.06 feet to a PK nail; S27°51'15"E - 103.05 feet to a rebar; S28°34'06"E - 516.43 feet to a rebar; in a curve to the right having a radius of 52.17 feet, an arc distance of 35.19 feet, the chord of which runs S48°47'02"E - 34.53 feet to a rebar; S28°43'30"E - 131.12 feet to a rebar; S21° 53'30"E - 101.50 feet to a rebar; S31°13'04"E - 149.11 feet to a rebar; S31°45'00"E - 19.48 feet to L rebar; S40°50'56"E - 84.66 feet to a PK nail; S40°56'04"E - 109.70 feet to a rebar; thence turning and running along property of Woodland Village Apartments S42°18'17"W - 285.91 feet to a rebar; thence turning and running along property of Diane R. Spearman as follows: N59°24'55"W - 186.52 feet to a rebar; N64° 17'05"W - 51.76 feet to an open top; S03°25'35"E - 104.94 feet to an open top; thence turning and running along Brookwood Court S85°00'43"W - 65.00 feet to a calculated point; thence turning and running along property of McQueen Smith as follows: N04°44'57"W - 120.00 feet to an open top; N53°20'55"W - 66.63 feet to an open top; S63°51'41"W - 73.18 feet to pinch top; thence turning and running along property of Scott L Whelchel & Dana H, Whelchel N26°02'32"W - 65.25 feet to an open top; thence turning and running along property of David B. Tate as follows: N26°28'42"W - 65.03 feet to a rebar; N26029'46"W- 64.72 feet to a calculated point in concrete; S63°33'42"W - 150.00 feet to a rebar; thence turning and running along Colin Kelly Drive as follows: N25°26'03"W - 280.00 feet to a rebar, in a curve to the left having a radius of 223.79 feet, an arc distance of 77.04 feet, the chord of which runs N52°37'33"W - 76.66 feet to a rebar; in a curve to the left having a radius of 223.79 feet, an arc distance of 77.05 feet, the chord of which runs S87°56'06"W - 76.67 feet to a rebar; S63°34'32"W - 250.47 feet to an open top; thence turning and running along McArthur Avenue N26°18'28"W - 70.15 feet to a rebar; thence turning and running along the terminus of McArthur Avenue and along property of Paula R.

Bunt S63°46'47"W - 199.92 feet to an open top; thence turning and running along property of Sunnyside Properties, Inc. as follows: N26°38'48"W - 102.35 to an open top; N26°31'13"W - 77.43 feet to an open top; thence turning and continuing along property of Sunnyside Properties, Inc. and along property of Claiborne E. Reeder and Nancy P. Reeder N25°58'44"W - 60.13 feet to an open top; thence turning and continuing along property of Claiborne E. Reeder and Nancy P. Reeder and long properties of C. H. Reeder and Nancy P. Reeder, Robert G. Cook and Robin D. Anderson, George L. Bryant, Catherine H. Bradley, Martha Diaz, and Joseph M. Diaz and Martha Diaz N26°15'04"W - 324.64 feet to an open top; thence turning and running along property of Sharon Kay Ford as follows: N63°38'18" - 52.16 feet to an open top; N76°42'51"W - 78.96 feet to an open top; thence turning and running along properties of Martha Diaz and Lorraine M. Tablas N25°58'03"W - 103.51 feet to a rebar; thence turning and continuing along property of Lorraine M. Tablas S63°34'24"W - 53.87 feet to a rebar; thence turning and running along of Bruckner Associates A Partnership as follows: N26°38'33"W - 87.35 feet to a rebar; S68°31'11"W - 30.08 feet to a pinch top; thence turning and running along property of Carolina Associates, A.S.C. Partnership N26°31'33"W - 79.43 feet to an open top; thence turning and running along Forest Drive N68°21'02"E - 95.19 feet to a rebar; thence turning and running along property of Olin W. Hollis, Jr. as follows: S09°42'05"E - 31.88 feet to a PK nail; in a curve to the left having radius of 100.00 feet, an arc distance of 84.59 feet, the chord of which runs S35°10'53"E - 82.09 feet to a PK nail; S58°09'49"E - 36.04 feet to a rebar; N44°44'46"E - 164.97 feet to magnetic nail; N36°34'36"W - 59.14 feet to an "X" in concrete; thence turning and running along Forest Drive as follows: N68°16'41"E - 594.92 feet to a rebar; in a curve to the right having a radius of 92.93 feet, an arc distance of 44.96 feet, the chord of which runs N81°57'26"E - 44.52 feet to a rebar; N09°27'43"E - 23.49 feet to an "X" cut in concrete; N69° 11 '44"E - 140.34 feet to a rebar; S46°09'12"E - 29.02 feet to a rebar; in a curve to the right having a radius of 89,22 feet, an arc distance of 55.43 feet, the chord of which runs N60°56'39"E - 54.54 feet to a rebar; N78°48'08"E - 17.00 feet to a calculated point in grate; thence turning and running along property of Colt Site 12 Inc. as follows: S16°47'13"E - 165.96 feet to a rebar; N77°22'02"E - 169.17 feet to the Point of Beginning.

TMS No.: R13908-04-36 (for informational purposes only)

PARCEL 3 (TGI FRIDAY'S PARCEL)

Being the following tracts and parcels located in Richland County, South Carolina and being more particularly described as follows: That parcel of land, with improvements thereon, situate in the Town of Forest Acres, Richland County, South Carolina, containing 0.143 acre as shown on Boundary Survey of Richland Mall TGI Friday's prepared for Windsor Richland Mall, Limited Partnership by B. P. Barber & Associates, Inc. dated March 29, 2005, recorded in the Office of the Register of Deeds for Richland County on April 19, 2005 in Book 1044 at page 323, said plat being incorporated herein by reference for a more complete description of said property,

Together with all rights and easements, established pursuant to Reciprocal Easement, Covenant, Operation and Restriction Agreement and Declaration between BRC Richland, LLC and Windsor Richland Mall, L.P. dated September 7, 2005 and recorded on September 12, 2005 in Book 1097 at Page 2024.

TMS No.: R13908-04-37 (for informational purposes only)

EXHIBIT B
FORM OF INTERGOVERNMENTAL AGREEMENT

STATE OF SOUTH CAROLINA)
)
CITY OF FOREST ACRES)
)
COUNTY OF RICHLAND)
)
)
)

INTERGOVERNMENTAL AGREEMENT

THIS INTERGOVERNMENTAL AGREEMENT is dated and effective as of October [], 2022 (this “Intergovernmental Agreement”), and is by and between Richland County, South Carolina, a county and political subdivision of the State of South Carolina (“Richland County”) and the City of Forest Acres, South Carolina, a municipal corporation and political subdivision of the State of South Carolina (the “City” and together with Richland County, the “Parties” and each individually, a “Party”).

RECITALS

WHEREAS, the Parties desire to encourage an economic development project (“Project”) which is expected to result in the redevelopment of the Richland Fashion Mall site located in the City and surrounding areas (collectively, “Site”); and

WHEREAS, it is expected that the redevelopment will increase the tax base of Richland County, encourage additional investment in taxable real and personal property and job creation in the City and Richland County, and remove and transform vacant commercial property; and

WHEREAS, in consideration of these anticipated benefits, SE Forest Acres, LLC, the company undertaking the Project (“Company”), has negotiated certain infrastructure credits (“Credits”) with Richland County under the terms of that certain Infrastructure Credit Agreement (the “Credit Agreement”) to pay costs of, among other things, designing, acquiring, constructing, improving or expanding the infrastructure serving the Project and for improved and unimproved real estate and personal property (collectively, “Infrastructure”) at the Site; and

WHEREAS, Richland County desires to locate the real and personal property comprising the Site (collectively, “Property”) in a multicounty industrial or business park (“Park”) in order to provide the Credits to the Company for the Infrastructure pursuant to § 4-1-175 of the Code of Laws of South Carolina 1976, as amended;

WHEREAS, Fairfield County, South Carolina (“Fairfield County”) and Richland County (jointly the “Counties”) are authorized under pursuant to Article VIII, Section 13(D) of the South Carolina Constitution 1895, as amended, and South Carolina Code Annotated Section 4-1-170 (collectively, the “MCIP Law”) to jointly develop a multi-county industrial or business park within the geographical boundaries of one or both of the member counties; and

WHEREAS, the Counties have entered into a “Master Agreement Governing the Richland Mall Business Park” (the “Master Agreement”), the provisions of which govern (i) the operation of the Park, including the sharing of expenses and revenues of the Park, and (ii) the manner in which the revenue is to be distributed to each of the taxing entities within each of the Counties; and

WHEREAS, the City and Richland County desire to enter into this Intergovernmental

Agreement to: (i) confirm the purpose of the Park; (ii) identify the location of the Park; (iii) determine the eligibility criteria for inclusion of Property in the Park; (iv) memorialize the methodology by which and the amount of fee-in-lieu-of *ad valorem* taxes with respect to the property located in the Park (“Fees”) will be distributed within the County; and

WHEREAS, the City and Richland County each acting by and through their respective governing bodies have authorized the execution and delivery of this Intergovernmental Agreement.

NOW THEREFORE, in consideration of the mutual agreement, representations, and benefits contained in this Intergovernmental Agreement and for other good and valuable consideration, the receipt and sufficiency of which is hereby acknowledged, the Parties hereby contractually agree as follows:

1. Binding Agreement; Representations.

(A) This Intergovernmental Agreement serves as a written instrument setting forth the entire agreement between the Parties and shall be binding on the Parties, their successors and assigns.

(B) Each of the Parties represents and warrants that: (i) it has the full legal right, power, and authority to enter into this Intergovernmental Agreement and carry out and consummate all other transactions contemplated by this Intergovernmental Agreement; (ii) it has duly authorized the execution, delivery, and performance of its obligations under this Intergovernmental Agreement and the taking of any and all actions as may be required on its part to carry out, give effect to, and consummate the transactions contemplated by this Intergovernmental Agreement; and (iii) this Intergovernmental Agreement constitutes a legal, valid, and binding obligation of each respective Party, enforceable in accordance with its terms, subject to applicable bankruptcy, insolvency and similar laws affecting creditors’ rights generally, and subject, as to enforceability, to general principles of equity regardless of whether enforcement is sought in a proceeding in equity or at law.

2. Authorization/Purpose. The MCIP Law provides that counties may jointly develop an industrial or business park with other counties within the geographical boundaries of one or more of the member counties, provided that certain conditions specified therein are met. The Master Agreement meets the conditions set forth in the MCIP Law and its provisions shall govern the operation of the Park. Further, and as acknowledged in the Master Agreement, the City has consented to the creation of the Park.

3. Location of the Park.

(A) The Park consists of property located in the City as is hereinafter more specifically described in Exhibit A hereto (the “Property”). The Property shall be subject, beginning with fee payments received for tax year 2022, to the distribution of revenues provided for in the Master Agreement. It is specifically recognized that the Park may consist of non-contiguous properties. The boundaries of the Park may be enlarged from time to time, but only in accordance with the terms of the Master Agreement.

(B) In the event of any enlargement or diminution of the boundaries of the Park through the addition or subtraction of property, this Intergovernmental Agreement shall be deemed amended and there shall be attached hereto a revised Exhibit A which shall contain a legal description of the boundaries of the Park. Upon the inclusion of any property in the Park, it shall immediately be subject to the distribution of revenue as set forth in the Master Agreement.

(C) Richland County shall not consent to the enlargement or diminution of the boundaries of the Park through the addition or subtraction of the property located within the City without receiving the City's prior written consent to any such enlargement or diminution.

4. **Eligibility for Inclusion in Fee Distribution.** Only the property reflected in Exhibit A from time to time shall be in the Park as of a given time, and, accordingly, only that property is subject to the fee distribution set forth in the Master Agreement.

5. **Collection and Distribution of Fee-In-Lieu-Of-Tax Payment.**

(A) Subject to execution and delivery of the Master Agreement, Richland County will collect all Fees generated from Property located in Richland County. Once collected, the County will distribute the Fees as provided in the Master Agreement.

(B) Richland County shall not amend the distribution of Fees to the taxing entities within Richland County as set forth in the Master Agreement without receiving the City's prior written consent.

(C) The City acknowledges and consents to the terms of the Credit Agreement. Richland County hereby covenants that it will not amend the terms of the Credit Agreement or any other fee-in-lieu of tax or infrastructure credit agreement to which the Property may be subject, without the prior written consent of the City if such amendment would have the effect of diminishing the amount of Fees received by the City.

6. **Master Agreement.** The Master Agreement is hereby incorporated herein as fully as if set forth verbatim in its entirety. The Master Agreement shall be the basis for all terms and provisions not otherwise specifically addressed by this Intergovernmental Agreement.

7. **Records.** The Parties covenant and agree that, upon the request of either, the other will provide to the requesting Party copies of the fee-in-lieu-of-tax records and distributions pertaining to Property, as such records become available in the normal course of City and Richland County procedures.

8. **Severability.** In the event and to the extent, and only to the extent, that any provision or any part of a provision of this Intergovernmental Agreement shall be held invalid or unenforceable by any court of competent jurisdiction, such holding shall not invalidate or render unenforceable the remainder of that provision or any other provision or part of a provision of this Intergovernmental Agreement.

9. **Termination.** The City and Richland County agree that this Intergovernmental Agreement may not be terminated, except by mutual written agreement, unless the Master

Agreement should terminate prior to that time, in which case this Intergovernmental Agreement shall terminate concurrently with the Master Agreement.

10. **Counterparts; Execution.** The City and Richland County may executed this Intergovernmental Agreement in multiple counterparts, all of which, together, constitute but one and the same document.

[Signature Pages to Follow]

IN WITNESS WHEREOF, Richland County has caused this Intergovernmental Agreement to be signed by its Chairman of County Council, its corporate seal to be reproduced hereon and the same to be attested by the Clerk to County Council.

RICHLAND COUNTY, SOUTH CAROLINA

[SEAL]

By: _____
Chairman of County Council

ATTEST:

By: _____
Clerk to County Council
Richland County, South Carolina

(SIGNATURE PAGE)

IN WITNESS WHEREOF, the City has caused this Intergovernmental Agreement to be signed by its Mayor, its corporate seal to be reproduced hereon and the same to be attested by the City Administrator.

CITY OF FOREST ACRES, SOUTH CAROLINA

[SEAL]

By: _____
Mayor

ATTEST:

By: _____
City Administrator

(SIGNATURE PAGE)

EXHIBIT A

Legal Description of the Property

THE LAND REFERRED TO HEREIN BELOW IS SITUATED IN THE COUNTY OF RICHLAND, STATE OF SOUTH CAROLINA AND IS DESCRIBED AS FOLLOWS:

ALL THAT CERTAIN tract of land, with all improvements thereon, situate in the Town of Forest Acres, Richland County, South Carolina, containing 32.9393 Acres as shown on a ALTA/ACSM Land Title Survey Prepared for JTL Capital, LLC by Steadman & Associates, Inc., dated October 2, 2002, revised December 13, 2002, recorded in the Office of the Register of Deeds for Richland County in Book 739 at Page 10, said plat being incorporated herein by reference, said property being more particularly described as follows:

BEGINNING at a point designated as "POB", said point being a PK nail along the western margin of the right-of-way of Beltline Boulevard (S.C. Highway No. 16) where the subject property corners with property of Colt Site 12 Inc. a distance of 165.15 feet from the intersection of Beltline Boulevard with the southern margin of the right-of-way of Forest Drive (S.C. Highway No. 12) and running along Beltline Boulevard as follows: in a curve to the right having a radius of 141.03 feet, an arc distance of 38.64 feet, the chord of which runs S 06-00-05 W, 38.52 feet to a rebar; S76-30-04 E, 29.01 feet to an "X" in concrete S 24-20-15 E, 66.01 feet to a PK nail; S 20-58-56 W, 29.14 feet to a rebar; in a curve to the right have a radius of 33.77 feet, an arc distance of 22.47 feet, the chord of which runs S 49-48-51 E, 22.06 feet to a PK nail; S 27-51-15 E, 103.05 feet to a rebar; S 28-34-06 E, 516.43 feet to a rebar; in a curve to the right having a radius of 52.17 feet, an arc distance of 35.19 feet, the chord of which runs S 48-47-02 E, 34.53 feet to a rebar; S28-43-30 E, 131.12 feet to a rebar; S 21-53-30 E, 101.50 feet to a rebar; S 31-13-04 E, 149.1 1 feet to a rebar; S 31-45-00 E, 19.48 feet to a rebar; S 40-50-56 E, 84.66 feet to a PK nail; S 40-56-04 E, 109.70 feet to a rebar; thence turning and running along property of Woodland Village Apartments S 42-18-17 W, 285.91 feet to a rebar; thence turning and running along property of Diane R. Spearman as follows: N 59-24-55 W, 186.52 fee to a rebar; N 64-17-05 W, 51.76 feet to an open top; S 03-25-35 E, 104.94 feet to an open top; thence turning and running along Brookwood Court S 85-00-43 W, 65.00 feet to a calculated point; thence turning and running along property of McQueen Smith as follows: N04-44-57 W, 120.00 feet to an open top; N 53-20-55 W, 66.63 feet to an open top; S 63-51-41 W, 73.18 feet to a pinch top; thence turning and running along property of Scott L. Whelchel & Dana H. Whelchel N 26-02-32 W, 65.25 feet to an open top; thence turning and running along property of David B. Tate as follows: N 26-28-42 W, 65.03 feet to a rebar; N-26-29-46 W, 64.72 feet to a calculated point in concrete; S 63-33-42 W, 150.00 feet to a rebar; thence turning and running along Colin Kelly Drive as follows: N 25-26-03 W, 280.00 feet to a rebar; in a curve to the left having a radius of 223.79 feet, an arc distance of 77.04 feet, the chord of which runs N 52-37-33 W, 76.66 feet to a rebar; in a curve to the left having a radius of 223.79 feet, an arc distance of 77.05 feet, the chord of which runs S 87-56-06 W, 76.67 feet to a rebar; S 63-34-32 W, 250.47 feet to an open top; thence turning and running along McArthur Avenue N 26-18-28 W, 70.15 feet to a rebar; thence turning and running along the terminus of McArthur Avenue and along property of Paula R. Bunt S63-46-47 W, 199.92 feet to an open top; thence turning and running along property of Sunnyside Properties, Inc. as follows: N 26-38-48 W, 102.35 feet to an open top; N 26-31-13 W, 77.43 feet to an open top; thence turning and continuing along property of Sunnyside Properties, Inc. and along property of Claiborne E. Reeder & Nancy Reeder N 25-58-44 W, 60.13 feet to an open top; thence turning and continuing along property of Claiborne E. Reeder & Nancy P. Reeder and along properties of C.E. Reeder & Nancy P. Reeder, Robert G. Cook & Robin D. Anderson, George L. Bryant, Catherine H. Bradley, Martha Diaz, and Joseph M. Diaz & Martha Diaz N 26-15-04 W, 324.64 feet to an open top; thence turning and running along property of Sharon Kay Ford as follows: N 63-38-18 E, 52.16 feet to an open top; N 76-42-51 W, 78.96 feet to an open top; thence turning and running along properties of Martha Diaz and Lorraine M. Tablas N 25-58-03 W, 103.51 feet to a rebar, thence turning and continuing along property of Lorraine M. Tablas S 63-34-24 W, 53.87 feet to a rebar; thence turning and running along property of Buckner Associates A Partnership as follows: N 26-38-33 W, 87.35 feet to a rebar; S 68-31-11 W, 30.08 feet

to a pinch top; thence turning and running along property of Carolina Associates, A S.C. Partnership N 26-31-33 W, 79.43 feet to an open top; thence turning and running along Forest Drive N 68-21-02 E, 95.19 feet to a rebar; thence turning and running along property of Olin W. Hollis, Jr. as follows: S 09-42-05 E, 31.88 feet to a PK nail; in a curve to the left having a radius of 100.00 feet, an arc distance of 84.59 feet, the chord of which runs S 35-10-53 E, 82.09 feet to a PK nail; S 58-09-49 E, 36.04 feet to a rebar; N 44-44-46 E, 164.97 feet to a magnetic nail; N 36-34-36 W, 59.14 feet to an "X" in concrete; thence turning and running along Forest Drive as follows: N 68-16-41 E, 594.92 feet to a rebar; in a curve to the right having a radius of 92.93 feet, an arc distance of 44.96 feet, the chord of which runs N81-57-26 E, 44.52 feet to a rebar; N 09-2743 E, 23.9 feet to an "X" cut in concrete; N 69-11-44 E, 140.34 feet to a rebar; S 46-09-12 E, 29.02 feet to a rebar; in a curve to the right having a radius of 89.22 feet, an arc distance of 55.43 feet, the chord of which runs N 60-56-39 E, 54.54 feet to a rebar; N78-48-08 E, 17.00 feet to a calculated point in grate; thence turning and running along property of Colt Site 12 Inc. as follows: S 16-47-13 E, 165.96 feet to a rebar; N 77-22-02 E, 169.17 feet to the POINT OF BEGINNING.

LESS AND EXCEPT: "TGI Friday's Parcel"

ALL THAT CERTAIN piece, parcel or tract of land, with all improvements thereon, situate, lying and being in the County of Richland, State of South Carolina, containing 0.143 acres, according to a plat of survey entitled "Boundary Survey of Richland Mall TGI Friday's", prepared by B. P. Barber & Associates, Inc., dated March 19, 2005 and recorded on April 19, 2005 in the Office of the Register of Deeds for Richland County in Book 1044 at Page 323. Reference to said plat is hereby made for a metes and bounds description thereof.

LESS AND EXCEPT: "Verizon Wireless Parcel"

ALSO: ALL THAT CERTAIN piece, parcel or tract of land, with all improvements thereon, situate, lying and being in the County of Richland, State of South Carolina, containing 9.391 acres, according to a plat of survey entitled "Boundary Survey for Richland Mall Verizon Wireless", prepared by B. P. Barber & Associates, Inc., dated April 4, 2005, last revised June 7, 2005, and recorded on June 14, 2005 in the Office of the Register of Deeds for Richland County in Book 1063 at Page 652. Reference to said plat is hereby made for a metes and bounds description thereof.

LESS AND EXCEPT: "Bank of America Parcel"

ALL THAT CERTAIN piece, parcel, or tract of land, with all improvements thereon, situate, lying and being in the County of Richland, State of South Carolina, containing 0.77 acres, according to a plat of survey entitled "Plat Prepared for Windsor Richland Mall, L.P., a Texas Limited Partnership", prepared by Baxter Land Surveying Co., Inc., dated February 11, 2003, and recorded on February 28, 2005 in the Office of the Register of Deeds for Richland County in Book 1027 at Page 2697. Reference to said plat is hereby made for a metes and bounds description thereof.

TMS Nos.: R13908-04-35; R14001-11-11; and R14005-08-002 (for informational purposes only)

AND ALSO

(SIGNATURE PAGE)

THE LAND REFERRED TO HEREIN BELOW IS SITUATED IN THE COUNTY OF RICHLAND, STATE OF SOUTH CAROLINA AND IS DESCRIBED AS FOLLOWS:

PARCEL 1 (VERIZON WIRELESS PARCEL)

All that certain piece, parcel or of land with the improvements thereon, situate, lying and being in the County of Richland, State of South Carolina; the same being shown as 9.391 acres on a Boundary Survey of Richland Mall Verizon Wireless for Windsor Richland Mall, Limited Partnership by B.P. Barber & Associates, Inc. dated April 4, 2005, revised April 16, 2005, last revised June 7, 2005 and recorded in the Office of the Register of Deeds for Richland County on June 14, 2005 in Book 1063 at page 652.

PARCEL 2 (EASEMENT PARCEL)

Together with rights under the Reciprocal Easement, Covenant, Operation and Restriction Agreement and Declaration dated September 7, 2005 by and between BRC Richland, LLC, a Georgia liability company and Windsor Richland Mall, L.P., a Texas limited partnership, to be recorded, and being more particularly as:

That certain tract of land, with improvements thereon, situate, in the Town of Forest Acres, Richland County, South Carolina, containing 32.9393 acres as shown on ALTA/ACSM Land Title Survey prepared for JTL Capital, LLC by Steadman & Associates, Inc. dated October 3, 2002, revised December 13, 2002, in the Office of the Register for Richland County in Book 739 at page 10, said plat being incorporated herein by reference, said property being more particularly described as follows:

BEGINNING at a point designated as "POB", point being PK nail along the western margin of the right-of-way of Beltline Boulevard (SC. Highway No. 16) where the subject property corners with property of Colt Site 12 Inc. a distance of 165.15 feet from the intersection of Beltline Boulevard with the southern margin of the right-of-way of Forest Drive (SC Highway No. 12) and running along Beltline Boulevard as follows: in a curve to the right having a radius of 141.03 feet, an arc distance of 38.64 feet, the chord of which runs S06°00'05"W - 38.52 feet to a rebar, S76°30'04"E - 29.01 feet to an "X" in concrete; S24°20'15"E - 66.01 feet to a PK nail; S20°58'56"W - 29.14 to a rebar; in a curve to the right have radius of 33.77 feet, an arc distance of 22.47 feet, the chord of which runs S49°48'51"E - 22.06 feet to a PK nail; S27°51'15"E - 103.05 feet to a rebar; S28°34'06"E - 516.43 feet to a rebar; in a curve to the right having a radius of 52.17 feet, an arc distance of 35.19 feet, the chord of which runs S48°47'02"E - 34.53 feet to a rebar; S28°43'30"E - 131.12 feet to a rebar; S21° 53'30"E - 101.50 feet to a rebar; S31°13'04"E - 149.11 feet to a rebar; S31°45'00"E - 19.48 feet to L rebar; S40°50'56"E - 84.66 feet to a PK nail; S40°56'04"E - 109.70 feet to a rebar; thence turning and running along property of Woodland Village Apartments S42°18'17"W - 285.91 feet to a rebar; thence turning and running along property of Diane R. Spearman as follows: N59°24'55"W - 186.52 feet to a rebar; N64° 17'05"W - 51.76 feet to an open top; S03°25'35"E - 104.94 feet to an open top; thence turning and running along Brookwood Court S85°00'43"W - 65.00 feet to a calculated point; thence turning and running along property of McQueen Smith as follows: N04°44'57"W - 120.00 feet to an open top; N53°20'55"W - 66.63 feet to an open top; S63°51'41"W - 73.18 feet to pinch top; thence turning and running along property of Scott L Whelchel & Dana H, Whelchel N26°02'32"W - 65.25 feet to an open top; thence turning and running along property of David B. Tate as follows: N26°28'42"W - 65.03 feet to a rebar; N26029'46"W- 64.72 feet to a calculated point in concrete; S63°33'42"W - 150.00 feet to a rebar; thence turning and running along Colin Kelly Drive as follows: N25°26'03"W - 280.00 feet to a rebar, in a curve to the left having a radius of 223.79 feet, an arc distance of 77.04 feet, the chord of which runs N52°37'33"W - 76.66 feet to a rebar; in a curve to the left having a radius of 223.79 feet, an arc distance of 77.05 feet, the chord of which runs S87°56'06"W - 76.67 feet to a rebar; S63°34'32"W - 250.47 feet to an open top; thence turning and running along McArthur Avenue N26°18'28"W - 70.15 feet to a rebar; thence turning and running along the terminus of McArthur Avenue and along property of Paula R.

(SIGNATURE PAGE)

Richland County Council Request for Action

Subject:

An Ordinance Amending the Richland County Code of Ordinances, Chapter 2, Administration; Article II, County Council; Section 2-14, Compensation of Council Members; so as to reflect the new annual salary for County Council

Notes:

First Reading: October 18, 2022

Second Reading: October 25, 2022

Third Reading: November 1, 2022 {Tentative}

Public Hearing: November 1, 2022

STATE OF SOUTH CAROLINA
COUNTY COUNCIL FOR RICHLAND COUNTY
ORDINANCE NO. ____-22HR

AN ORDINANCE AMENDING THE RICHLAND COUNTY CODE OF ORDINANCES, CHAPTER 2, ADMINISTRATION; ARTICLE II, COUNTY COUNCIL; SECTION 2-14, COMPENSATION OF COUNCIL MEMBERS; SO AS TO REFLECT THE NEW ANNUAL SALARY FOR COUNTY COUNCIL.

Pursuant to the authority granted by the Constitution and the General Assembly of the State of South Carolina, BE IT ENACTED BY THE COUNTY COUNCIL FOR RICHLAND COUNTY:

SECTION I. The Richland County Code of Ordinances, Chapter 2, Administration; Article II, County Council; Section 2-14, Compensation of council members; is hereby amended to read as follows:

Sec. 2-14. Compensation of council members.

The compensation of members of the county council shall be equal to 80% of the minimum annual salary of an employee of Richland County Government. The chair of the county council shall, during his/her term as chair, receive in addition to his/her annual compensation, the sum of 10% of the annual compensation, to compensate for the additional duties required by such position. No change in the compensation of the chair and members of county council shall be effective until the date of commencement of the terms of the chair and members of council elected at the general election following the changes.

SECTION II. Severability. If any section, subsection, or clause of this ordinance shall be deemed to be unconstitutional or otherwise invalid, the validity of the remaining sections, subsections, and clauses shall not be affected thereby.

SECTION III. Conflicting Ordinances Repealed. All ordinances or parts of ordinances in conflict with the provisions of this ordinance are hereby repealed.

SECTION IV. Effective Date. This ordinance shall be effective from and after _____.

RICHLAND COUNTY COUNCIL

BY: _____
Overture Walker, Chair

ATTEST THIS THE ____ DAY

OF _____, 2022

Anette Kirylo
Clerk of Council

First Reading: October 18, 2022
Second Reading: October 25, 2022 {Tentative}
Public Hearing: November 1, 2022
Third Reading: November 1, 2022

Richland County Council Request for Action

Subject:

Department of Public Works - Solid Waste & Recycling - Articulated Dump Truck

Notes:

October 25, 2022 – The Administration & Finance Committee forwarded this item to Council without a recommendation. Staff is to provide additional information regarding quotes received and any maintenance concerns.

**RICHLAND COUNTY
ADMINISTRATION**

2020 Hampton Street, Suite 4069
Columbia, SC 29204
803-576-2050



Agenda Briefing

Prepared by:	John Ansell	Title:	General Manager
Department:	Public Works	Division:	Solid Waste & Recycling
Date Prepared:	September 2, 2022	Meeting Date:	October 25, 2022
Legal Review	Patrick Wright via email	Date:	September 27, 2022
Budget Review	Abhijit Deshpande via email	Date:	September 30, 2022
Finance Review	Stacey Hamm via email	Date:	September 28, 2022
Approved for consideration:	Assistant County Administrator	John M. Thompson, Ph.D., MBA, CPM, SCEM	
Meeting/Committee	Administration & Finance		
Subject	Landfill Equipment Purchase		

RECOMMENDED/REQUESTED ACTION:

The Solid Waste & Recycling Division requests the purchase of a Caterpillar 730-04A Articulated, off-road Dump Truck.

Request for Council Reconsideration: Yes

FIDUCIARY:

Are funds allocated in the department’s current fiscal year budget?	<input checked="" type="checkbox"/>	Yes	<input type="checkbox"/>	No
If not, is a budget amendment necessary?	<input type="checkbox"/>	Yes	<input type="checkbox"/>	No

ADDITIONAL FISCAL/BUDGETARY MATTERS TO CONSIDER:

The County Fleet Manager received a price quote utilizing the Sourcewell Collective Agreement for a 2022 Caterpillar 730-04A Articulated Dump Truck in the amount of \$492,760.63. This price includes \$61,600.00 as trade value for the 2003 Volvo A30D articulated truck and all applicable sales tax. This equipment purchase is included in the Fiscal Year 2023 (FY-23) Solid Waste & Recycling budget.

Applicable department/grant key and object codes: 2101365004-531400

OFFICE OF PROCUREMENT & CONTRACTING FEEDBACK:

The Sourcewell Cooperative Agreement allows the County to leverage the cost savings of higher volume purchases through contracts established under public procurement rules and regulations. CAT was the highest ranked offeror for the Heavy Construction Equipment RFP. The truck price (excluding the trade in credit) is \$517,859.84; the open market price for the same truck not utilizing the cooperative agreement is \$527,200.

COUNTY ATTORNEY’S OFFICE FEEDBACK/POSSIBLE AREA(S) OF LEGAL EXPOSURE:

There are no legal concerns regarding this matter.

REGULATORY COMPLIANCE:

This replacement equipment purchase supports Solid Waste’s equipment needs as outlined in its Class 2 Landfill Permit to Operate.

MOTION OF ORIGIN:

There is no associated Council motion of origin.

Council Member	
Meeting	
Date	

STRATEGIC & GENERATIVE DISCUSSION:

The Solid Waste & Recycling Division requests County Council’s approval to purchase a 2022 Caterpillar 730-04A Articulated, off-road, Dump Truck. This purchase is required to replace the existing Volvo 2003 off-road Dump Truck. This 2003 model is nearly 20-years old, and it is becoming very difficult to obtain a reliable supply source of repair parts. Multiple break downs and lengthy wait times for parts have made this machine ineffective and uneconomical to operate.

ADDITIONAL COMMENTS FOR CONSIDERATION:

Solid Waste & Recycling utilizes this vehicle to haul large volumes of material to maintain landfill cover requirements, maintain its permitted compost area, and other duties as required through the course of any routine day of landfill operation. The replacement vehicle will add efficiency to landfill operations by requiring fewer staff hours to provide an expedient service while utilizing fewer County resources.

Additionally, although exceedingly rare, off road dump trucks serve a critical function in the event of a fire in the landfill.

ATTACHMENTS:

1. Blanchard Quote
2. 730-04A Specifications sheet



RICHLAND COUNTY, SOUTH CAROLINA
Requisition For Supplies/Services

Attachment 1

Department Account #
Requisition Sequence #

Vendor:
Company Name: Blanchard Caterpillar

Address:
 3151 Charleston Highway

City:	Columbia
State:	NC
Zip Code:	29172

Point of Contact (Name):
 Brian Smith

Telephone/Fax/e-mail: Phone: 803-518-0113
 Email: bsmith@blanchardmachinery.com

Ship To:
Department: Public Works- Solid Waste C & D Landfill

Address:
 1070 Caughman Road

City:	Columbia
State:	SC
Zip Code:	29203

Receiving Person (Name):
 John Ansell

Telephone/Fax/e-mail: Phone: 803-576-2384
 Email: ansell.john@richlandcountysc.gov

No.	Description, Specifications and/or Scope of Work	U/I	Qty	Unit Price	Total Price
1	Caterpillar 730-04A Articulated Dump Truck Sourcewell Contract #032119-CAT Richland County Participating Agency # 20410	each	1	\$517,859.84	\$517,859.84
2	Trade In 2003 Volvo A30D Articulated Dump Truck	each	1	-\$61,600.00	-\$61,600.00
3	Sales Tax	each	1	\$36,500.79	\$36,500.79
4	Total Cost	each	1	\$492,760.63	\$492,760.63
Contact: Bill Peters, County Fleet Manager 400 Powell Rd., Columbia, SC 29203 Phone: 803-576-2457 Email: peters.bill@richlandcountysc.gov					
Use:	Replaces LN001, 2003 Volvo A30D Articulated Dump Truck				

I certify that there are sufficient funds in my departmental budget to make this purchase. I further certify that there are sufficient unencumbered funds to pay for items requisitioned in my departmental budget for the current fiscal year. I hereby understand that I may be held personally liable for funds expended in excess of the amount appropriated by County Council for the current year.

W. H. Peters 
 Richland County Fleet Manager

August 26, 2022
 Date

Account Number

RAC-F-2000



Quotation

DATE 8/16/2022

3151 Charleston Hwy
 West Columbia SC 29172
 Phone (803) 518-0113 bsmith@blanchardmachinery.com

Quotation For:
 RICHLAND COUNTY
 Mr. Bill Peters

Prepared by: Brian Smith

REFERENCE NUMBER	DESCRIPTION	AMOUNT
485-1709	730-04A ARTICULATED TRUCK	
369-8730	TIRES, 750/65R25 MX ** XAD-65	
480-1980	AM/FM RADIO (BLUETOOTH READY)	
480-7003	WIPER, REAR	
481-8888	PRODUCT LINK, CELLULAR PLE641	
485-0331	SEAT, DELUXE	
567-7488	LUBRICATION, AUTOMATIC	
571-8585	BODY, STANDARD	
573-7897	TAILGATE, SCISSOR	
	SALES PRICE	\$517,859.84
	12 MONTH FULL MACHINE FACTORY WARRANTY	\$ -
	84 MONTH / 5,000 HOUR POWERTRAIN & HYDRAULIC WARRANTY	\$ -
TRADE IN	2003 VOLVO A30D S/N A30DV10561	\$ (61,600.00)
	SOURCEWELL CONTRACT NUMBER 032119-CAT	
	OMNIA PARTNERS CONTRACT NUMBER 161534	
	NASPO VALUEPOINT CONTRACT NUMBER OK-SW-192	

Plus any applicable sales tax

SUBTOTAL	\$456,259.84
TAX RATE	8.00%
SALES TAX	36,500.79
OTHER	-
TOTAL	\$ 492,760.63

Thank you for the opportunity to earn your business



730

Articulated Truck

Technical Specifications

Configurations and features may vary by region. Please consult your Cat® dealer for availability in your area.

Table of Contents

Specifications	2
Engine	2
Weights	2
Air Conditioning System	2
Body Capacities	2
Transmission	2
Sound Levels	2
Operating Weights	3
Body Plate	3
Body Plate Thickness	3
Service Refill Capacities	3
Body Hoist	3
Standards	3
Dimensions	4
Turning Circle	5
Steering	5
Optimal Loader/Truck Pass Matching	5
Gradeability/Speed/Rimpull	6
Retarding Performance	7
Standard and Optional Equipment	8

730 Articulated Truck Specifications

Engine

Engine Model	Cat C13	
Gross Power (SAE J1995:2014)	280 kW	375 hp
Net Power (SAE J1349:2011)	274 kW	367 hp
Engine Power (ISO 14396:2002)	276 kW	370 hp
Bore	130 mm	5.1 in
Stroke	157 mm	6.2 in
Displacement	12.5 L	762.8 in ³

- Advertised power is tested at 1,800 rpm.
- The net power advertised is the power available at the flywheel when the engine is equipped with alternator, air cleaner, muffler, and fan at minimum speed.
- Net power when the fan is at maximum speed is 254 kW (341 hp) per the SAE reference conditions.
- Meets U.S. EPA Tier 4 Final, EU Stage V, Korea Tier 4 Final, and Japan 2014 emission standards.
- DEF used in Cat SCR systems must meet the requirements outlined in ISO 22241-1. ISO 22241-1 requirements are met by many brands of DEF, including those that carry the AdBlue or API certifications.

No Engine Derating Below	3810 m	12,500 ft
Peak Engine Torque Gross (SAE J1995:2014)	2141 N·m	1,579 lbf·ft
Peak Engine Torque Net (SAE J1349:2011)	2107 N·m	1,554 lbf·ft
Peak Engine Torque Speed	1,200 rpm	

Weights

Rated Payload	28 tonnes	31 tons
---------------	-----------	---------

Air Conditioning System

- The air conditioning system on this machine contains the fluorinated greenhouse gas refrigerant R134a (Global Warming Potential = 1430). The system contains 1.1 kg of refrigerant which has a CO₂ equivalent of 1.716 metric tonnes.

Body Capacities

Heaped SAE 2:1	17.5 m ³	23.0 yd ³
Struck	13.3 m ³	17.4 yd ³
Tailgate Heaped SAE 2:1	18.8 m ³	24.6 yd ³
Tailgate Struck	13.9 m ³	18.2 yd ³

Transmission

Forward 1	8 km/h	5 mph
Forward 2	15 km/h	9 mph
Forward 3	22 km/h	14 mph
Forward 4	34 km/h	21 mph
Forward 5	47 km/h	29 mph
Forward 6	55 km/h	34 mph
Reverse 1	9 km/h	6 mph

Sound Levels

Interior Cab	72 dB(A)
--------------	----------

- The declared dynamic operator sound pressure level is 72 dB(A) when ISO 6396:2008 is used to measure the value for an enclosed cab. The measurement was conducted at 70% of the maximum cooling fan's speed. The sound level may vary at different cooling fan speeds. The measurement was conducted with the cab doors and the cab windows closed. The cab was properly installed and maintained.
- Hearing protection may be needed when operating with an open operator station and cab or when not properly maintained or with doors/windows open for extended periods or in noisy environments.

730 Articulated Truck Specifications

Operating Weights

Front Axle – Empty	15 000 kg	33,069 lb
Center Axle – Empty	4560 kg	10,053 lb
Rear Axle – Empty	4340 kg	9,568 lb
Total – Empty	23 900 kg	52,690 lb
Front Axle – Rated Load	3280 kg	7,231 lb
Center Axle – Rated Load	12 360 kg	27,249 lb
Rear Axle – Rated Load	12 360 kg	27,249 lb
Total – Rated Load	28 000 kg	61,729 lb
Front Axle – Loaded	18 280 kg	40,300 lb
Center Axle – Loaded	16 920 kg	37,302 lb
Rear Axle – Loaded	16 700 kg	36,817 lb
Total – Loaded	51 900 kg	114,420 lb

Body Plate

High strength Brinell HB450 wear resistant steel

Body Plate Thickness

Front Plate	7 mm	0.28 in
Base Plate	13 mm	0.51 in
Side Plates	11 mm	0.43 in

Service Refill Capacities

Fuel Tank	412 L	108.8 gal
DEF Tank	20 L	5.3 gal
Cooling System	83 L	21.9 gal
Hydraulic System	110 L	29.1 gal
Engine Crankcase	38 L	10.0 gal
Transmission	47 L	12.4 gal
Final Drives/Differential	125 L	33.0 gal
Output Transfer Gear Box	24 L	6.3 gal

Body Hoist

Raise Time	12 Seconds
Lower Time	8 Seconds

Standards

Brakes	ISO 3450:2011
Cab/FOPS	ISO 3449:2005 Level II
Cab/ROPS	ISO 3471:2008
Steering	ISO 5010:2019

730 Articulated Truck Specifications

Dimensions

All dimensions are approximate.

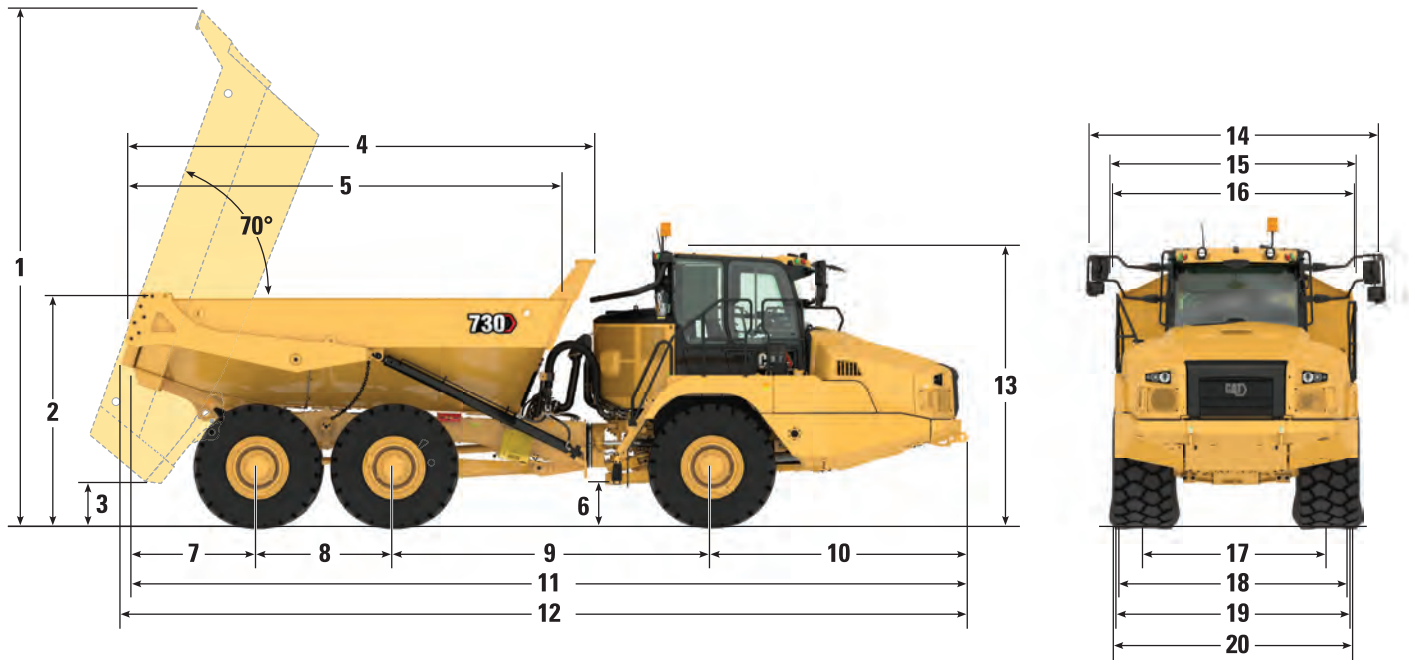

	mm	ft/in
1 Body Height Fully Tipped	6468	21'3"
2 Load Over Height	2916	9'5"
3 Ground Clearance – Body Fully Tipped	563	1'10"
4 Body Length	5783	19'0"
5 Body Length Inside	5411	17'9"
6 Ground Clearance	545	1'9"
7 Rear Axle Center to Body Rear	1556	5'1"
8 Mid Axle to Rear Axle Center	1700	5'7"
9 Mid Axle to Front Axle (Centers)	3979	13'1"
10 Front Axle Center to Machine Front	3210	10'6"
11 Overall Length	10 445	34'3"
12 Overall Length with Tailgate	10 593	34'8"
13 Height Transport Position	3508	11'6"
14 Overall Width	3676	12'1"
15 Width Over Tailgate/Width Including Tailgate	2984	9'10"
16 Body Width	2902	9'6"
17 Track Width	2275	7'6"
18 Width Over Tire	2877	9'5"
19 Width Over Fenders	2950	9'8"
20 Max Laden Over Tire Bulge	2950	9'8"

730 Articulated Truck Specifications

Turning Circle

Dimensions are for machines equipped with 23.5R25 tires.

Turning Dimensions

Steer Angle – From Center Left/Right	45°	
SAE Turning Radius	7470 mm	294 in
Clearance Radius	8075 mm	318 in
Inside Radius	3879 mm	153 in
Aisle Width	5332 mm	210 in

Steering

Lock to Lock 4.75 seconds at 60 rpm

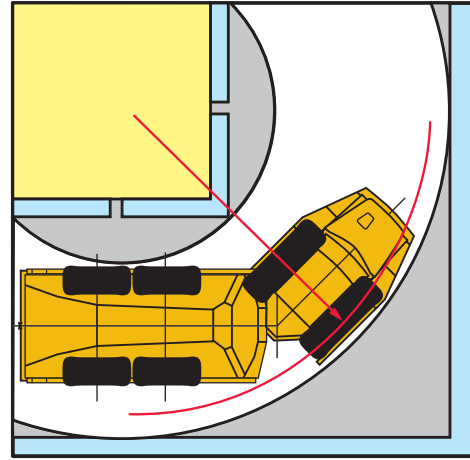

Optimal Loader/Truck Pass Matching

Hydraulic Excavators	349/352		336	
Passes	4-5		5-6	
Wheel Loaders	972M/972M XE	966M/966M XE	962M	950M
Passes	3-4	4	4-5	5

An optimum system match gives you a major productivity advantage. The 730 is an excellent match for the Cat 349/352 and 336 Hydraulic Excavators and Cat 972M, 966M, 962M, and 950M Wheel Loaders. Having matched loading and hauling tools results in increased production and lower system costs per unit of volume moved.

730 Articulated Truck Specifications

Gradeability/Speed/Rimpull

To determine performance, read from Gross Weight down to % Total Resistance. Total Resistance equals actual % grade plus 1% for each 10 kg/metric ton (20 lb/ton) of Rolling Resistance. From this point, read horizontally to the curve with the highest attainable speed range. Then, go down to Maximum Speed. Usable Rimpull depends on traction available.

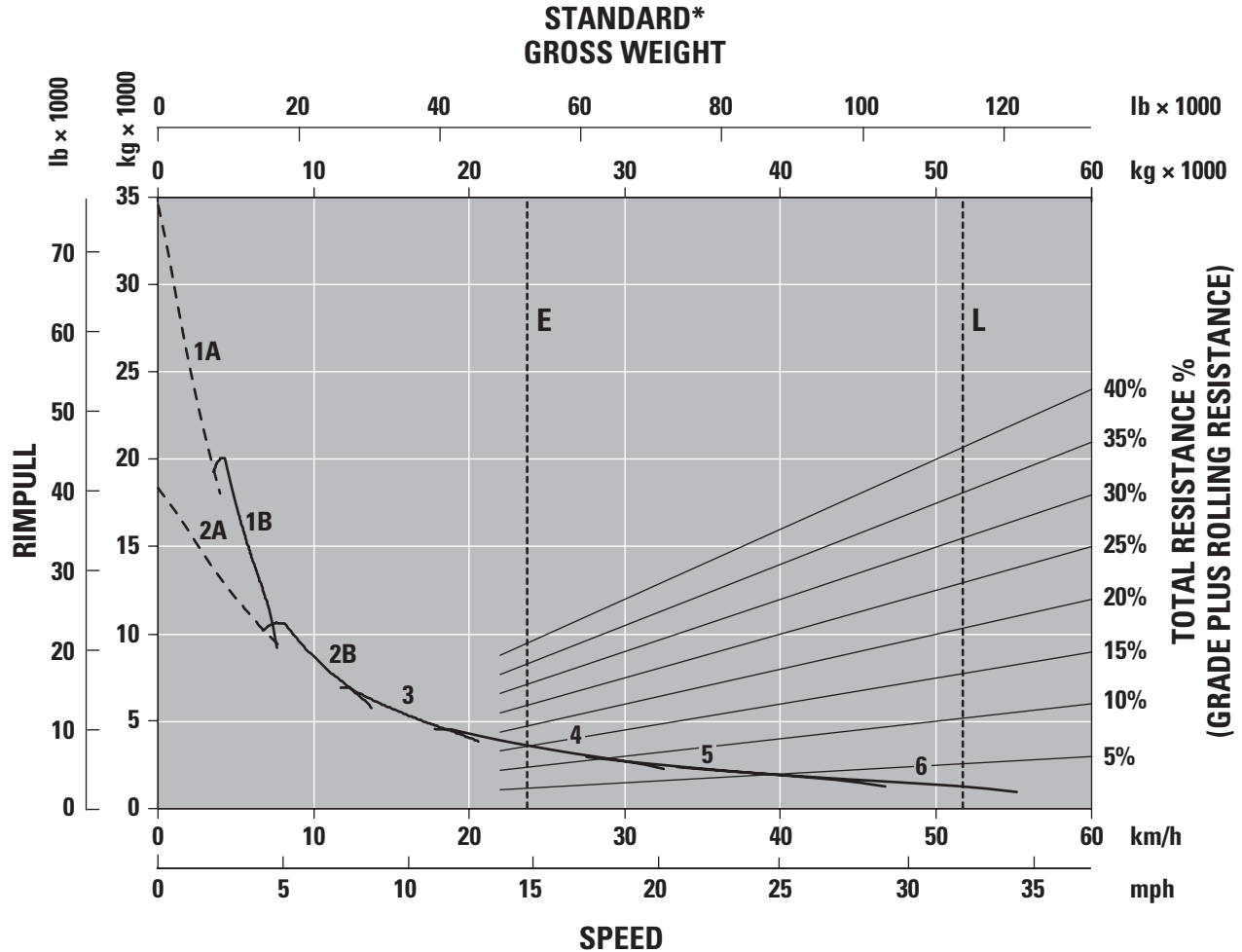

- 1A – 1st Gear (Converter Drive)
- 1B – 1st Gear (Direct Drive)
- 2A – 2nd Gear (Converter Drive)
- 2B – 2nd Gear (Direct Drive)
- 3 – 3rd Gear
- 4 – 4th Gear
- 5 – 5th Gear
- 6 – 6th Gear

- E – Empty 23 725 kg (52,305 lb)
- L – Loaded 51 725 kg (114,034 lb)
- * at sea level

Retarding Performance

To determine performance, read from Gross Weight down to % Effective Grade. Effective Grade equals actual % favorable grade plus 1% for each 10 kg/metric ton (20 lb/ton) of Rolling Resistance. From this point, read horizontally to the curve with the highest attainable speed range. Then, go down to Maximum Speed. Retarding effect on these curves represents full application of the retarder.

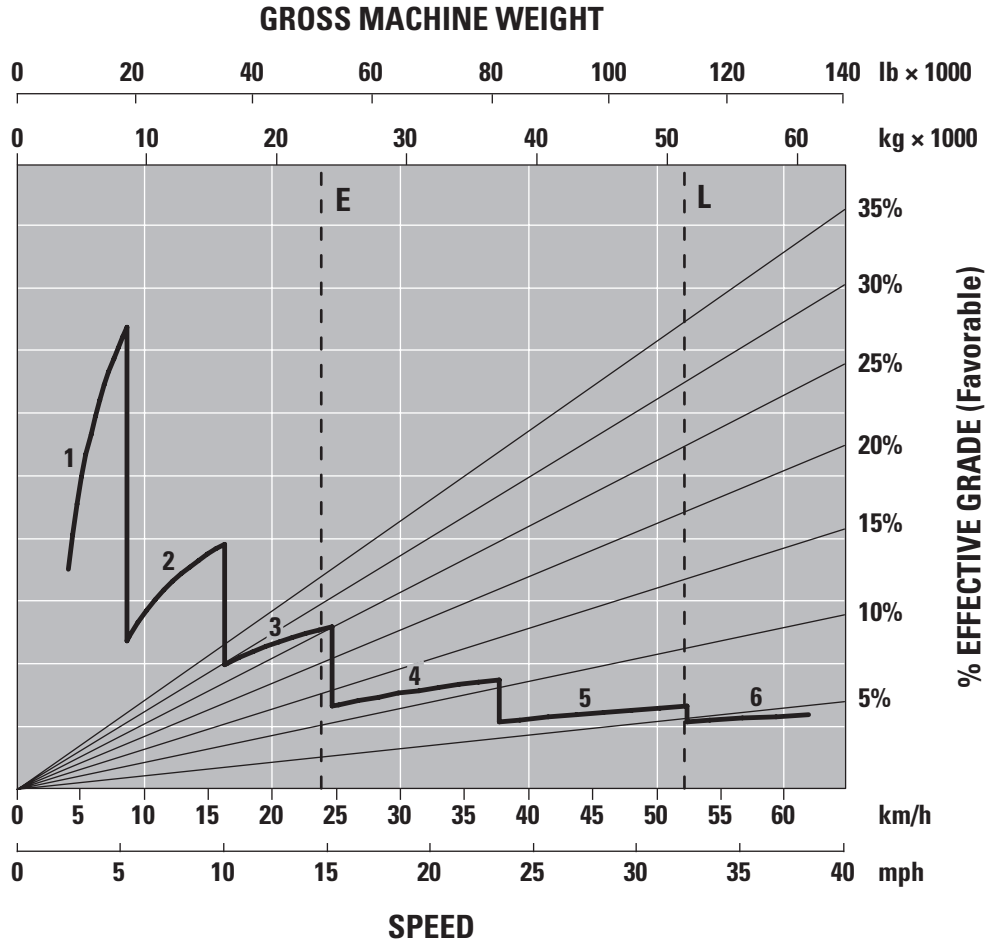

- 1 – 1st Gear
- 2 – 2nd Gear
- 3 – 3rd Gear
- 4 – 4th Gear
- 5 – 5th Gear
- 6 – 6th Gear

- E – Empty 23 725 kg (52,305 lb)
- L – Loaded 51 725 kg (114,034 lb)

730 Articulated Truck Standard & Optional Equipment

Standard and Optional Equipment

Standard and optional equipment may vary. Consult your Cat dealer for details.

	Standard	Optional		Standard	Optional
OPERATOR ENVIRONMENT			TECHNOLOGY		
Air conditioning with R134a refrigerant	✓		Cat Detect with Stability Assist	✓	
Adjustable air vents	✓		Cat Production Measurement payload monitoring system		✓
Combined gear selection and hoist control lever	✓		Machine Security System (MSS)		✓
Glass windows: front, laminated and tinted; sides and rear, toughened and tinted	✓		Product Link™ Elite: PLE641 (cellular)	✓	
Heater and defroster with four-speed fan	✓		Product Link Elite: PLE631 (satellite)		✓
Infrared glass, high ambient cab		✓	ELECTRICAL AND LIGHTING		
Liquid Crystal Display (LCD): alert indicator, selected gear and direction, speed or auto shift, review Operation and Maintenance Manual (OMM), primary steering failure warning, seat belt warning, secondary steering failure warning, Diesel Particulate Filter (DPF) regeneration filter, secondary steering energy source engaged, hour meter, retarder active	✓		Batteries (two) maintenance free	✓	
Mirrors, extensive arrangement for improved visibility	✓		Cold weather start attachment		✓
Mirrors, heated motorized		✓	Engine block heater		✓
Machine operation monitoring system: action lamp, engine oil pressure, primary steering system, left and right turn signal, high beam, coolant temperature, tachometer, parking brake, fuel level, transmission oil temperature, brake system, transmission hold, hoist control, hydraulic system, charging system, retarder, transmission fault, traction control system, check engine lamp	✓		Ether start		✓
Radio, Bluetooth® stereo system		✓	Electrical system: 24-volt, 10A 24- to 12-volt converter	✓	
Seats: operator – fully adjustable, air suspension, retractable lap belt; trainer – padded with retractable lap belt	✓		Flashing LED beacon		✓
Seat, heated/cooled		✓	Horn	✓	
Operator seat belt, four-point		✓	Lighting systems: cab interior, two head lamps, two width marker, two reversing, work light/cab access light, two stop/tail lights, front and rear direction indicators	✓	
Secondary steering, electro hydraulic	✓		Main disconnect switch	✓	
Storage: cup holder, flask receptacle, under seat storage, door pocket, behind operator seat storage, coat hook	✓		Remote starting receptacle (cables not included)	✓	
Sun visor	✓		Roof-mounted High Intensity Discharge (HID) work lights		✓
Tilt and telescopic steering wheel	✓		POWER TRAIN		
Touchscreen display incorporating the rearview camera video feed	✓		Auto shift six-speed forward and single-speed reverse transmission	✓	
Window blinds		✓	Cat C13 engine	✓	
Windows (tinted) opening both sides	✓		CX31 transmission	✓	
Windshield wiper and washer, two speed, intermittent (front)	✓		Cat Clean Emission Module (CEM) and exhaust aftertreatment package	✓	
Window wiper and washer, two speed (rear)	✓		Differentials: standard with automatic clutched inter- and cross-axle differential locks	✓	
			Dual circuit oil immersed, enclosed brakes – all wheels	✓	
			Retarder: engine compression brake	✓	
			Three axle, six-wheel drive	✓	
			SAFETY		
			Reverse alarm	✓	
			Rearview camera	✓	
			ROPS/FOPS cab	✓	
			GUARDS		
			Axle	✓	
			Crankcase	✓	
			Front dump body spill guard, integral part of fabricated body	✓	
			Radiator	✓	
			Rear window	✓	

730 Articulated Truck Standard & Optional Equipment

Standard and Optional Equipment

Standard and optional equipment may vary. Consult your Cat dealer for details.

	Standard	Optional
OTHER STANDARD AND OPTIONAL EQUIPMENT		
Auto lube installation for automatic greasing of bearings		✓
Bare chassis (no body) standard wheel base		✓
Bare chassis (no body) long wheel base		✓
Body liners		✓
Cold weather coolant -51° C (-60° F)		✓
Exhaust heated body		✓
Fast fuel fill		✓
Fuel additive, anti-waxing		✓

	Standard	Optional
OTHER STANDARD AND OPTIONAL EQUIPMENT (CONTINUED)		
Mud flaps: wheel arch and body mounted with transportation tiebacks		✓
Scissor tailgate		✓
S•O•S SM sampling valves		✓
Sound suppression (standard in EFTA)*		✓
Sound suppression (optional outside EFTA)*		✓
Tires, six 23.5R25, radial		✓
Tires, six 750/65R25, radial		✓
Vandalism protection: lockable caps		✓
Wheel chocks		✓

* EFTA countries are EU countries plus Iceland, Norway, Lichtenstein, and Switzerland.

For more complete information on Cat products, dealer services, and industry solutions, visit us on the web at www.cat.com.

Materials and specifications are subject to change without notice. Featured machines in photos may include additional equipment. See your Cat dealer for available options.

© 2021 Caterpillar. All Rights Reserved. CAT, CATERPILLAR, LET'S DO THE WORK, their respective logos, Product Link, S•O•S, "Caterpillar Corporate Yellow", the "Power Edge" and Cat "Modern Hex" trade dress as well as corporate and product identity used herein, are trademarks of Caterpillar and may not be used without permission.

AEXQ2714-01 (7-2021)
Build Number: 04A
(Aus-NZ, Europe,
Japan, N Am)

SOUTH CAROLINA

)

)

A RESOLUTION

RICHLAND COUNTY

)

COMMITTING TO NEGOTIATE A FEE-IN-LIEU OF AD VALOREM TAXES AGREEMENT BETWEEN RICHLAND COUNTY AND PROJECT WELLNESS; IDENTIFYING THE PROJECT; AND OTHER MATTERS RELATED THERETO

WHEREAS, Richland County, South Carolina (“County”), acting by and through its County Council (“County Council”) is authorized pursuant to the provisions of Title 12, Chapter 44, Code of Laws of South Carolina, 1976, as amended (“Act”) to encourage manufacturing and commercial enterprises to locate in the State of South Carolina (“South Carolina” or “State”) or to encourage manufacturing and commercial enterprises now located in the State to expand their investments and thus make use of and employ the manpower, products, and other resources of the State by entering into an agreement with a sponsor, as defined in the Act, that provides for the payment of a fee-in-lieu of *ad valorem* tax (“FILOT Payments”) with respect to economic development property, as defined in the Act;

WHEREAS, PROJECT WELLNESS, an entity whose name cannot be publicly disclosed at this time (“Sponsor”), desires to invest capital in the County in order to expand its manufacturing facility in the County (“Project”);

WHEREAS, the Project is anticipated to result in an investment of approximately \$81,000,000 in taxable real and personal property and the creation of approximately 94 new, full-time equivalent jobs; and

WHEREAS, as an inducement to the Sponsor to locate the Project in the County, the Sponsor has requested that the County negotiate an agreement (“Agreement”), which provides for FILOT Payments with respect to the portion of the Project which constitutes economic development property, as defined in the Act.

NOW, THEREFORE, BE IT RESOLVED by the County Council as follows:

Section 1. This Resolution is an inducement resolution for this Project for purposes of the Act.

Section 2. County Council commits to negotiate the Agreement, which provides for FILOT Payments with respect to the portion of the Project which constitutes economic development property. The further details of the FILOT Payments and the agreement will be prescribed by subsequent ordinance of the County to be adopted in accordance with South Carolina law and the rules and procedures of the County.

Section 3. County Council identifies and reflects the Project by this Resolution, therefore permitting expenditures made in connection with the Project before the date of this Resolution to qualify as economic development property, subject to the terms and conditions of the Agreement and the Act.

Section 4. This Resolution is effective after its approval by the County Council.

RESOLVED: November 1, 2022

RICHLAND COUNTY, SOUTH CAROLINA

Chair, Richland County Council

(SEAL)
ATTEST:

Clerk to County Council

4877-5466-9879 v.4 005084/09040, 7:53 PM, 10/16/2022

Richland County Council Request for Action

Subject:

Authorizing the execution and delivery of a fee-in-lieu of ad valorem taxes and incentive agreement by and between Richland County, South Carolina and Project Wellness to provide for payment of a fee-in-lieu of taxes; authorizing certain infrastructure credits; and other related matters

Notes:

First Reading:
Second Reading:
Third Reading:
Public Hearing:

STATE OF SOUTH CAROLINA
COUNTY COUNCIL FOR RICHLAND COUNTY
ORDINANCE NO. _____

AUTHORIZING THE EXECUTION AND DELIVERY OF A FEE-IN-LIEU OF AD VALOREM TAXES AND INCENTIVE AGREEMENT BY AND BETWEEN RICHLAND COUNTY, SOUTH CAROLINA AND PROJECT WELLNESS TO PROVIDE FOR PAYMENT OF A FEE-IN-LIEU OF TAXES; AUTHORIZING CERTAIN INFRASTRUCTURE CREDITS; AND OTHER RELATED MATTERS.

WHEREAS, Richland County, South Carolina (“County”), acting by and through its County Council (“County Council”) is authorized pursuant to the provisions of Title 12, Chapter 44, Code of Laws of South Carolina, 1976, as amended (“FILOT Act”), to encourage manufacturing and commercial enterprises to locate in the State of South Carolina (“South Carolina” or “State”) or to encourage manufacturing and commercial enterprises now located in the State to expand their investments and thus make use of and employ the manpower, products, and other resources of the State by entering into an agreement with a sponsor, as defined in the FILOT Act, that provides for the payment of a fee-in-lieu of *ad valorem* tax (“FILOT Payments”), with respect to economic development property, as defined in the FILOT Act;

WHEREAS, pursuant to Article VIII, Section 13 of the South Carolina Constitution and Title 4, Section 1, Code of Laws of South Carolina, 1976, as amended (collectively, “MCIP Act”), the County is authorized to jointly develop multicounty parks with counties having contiguous borders with the County and, in the County’s discretion, include property within the boundaries of such multicounty parks. Under the authority provided in the MCIP Act, the County has created a multicounty park with Fairfield County more particularly known as the I-77 Corridor Regional Industrial Park (“Park”);

WHEREAS, pursuant to the FILOT and MCIP Acts, the County is authorized to provide credits (“Infrastructure Credits”) against FILOT Payments derived from economic development property to pay costs of designing, acquiring, constructing, improving or expanding (i) infrastructure serving a project or the County and (ii) improved and unimproved real estate and personal property used in the operation of a commercial enterprise or manufacturing facility (“Infrastructure”);

WHEREAS, PROJECT WELLNESS, (“Sponsor”), desires to expand its manufacturing facilities in the County (“Project”) consisting of taxable investment in real and personal property of not less than \$81,000,000 and the creation of 94 new, full-time jobs; and

WHEREAS, at the request of the Sponsor and as an inducement to locate the Project in the County, the County desires to enter into a Fee-in-Lieu of *Ad Valorem* Taxes and Incentive Agreement with the Sponsor, as sponsor, and Sponsor Propco, as sponsor affiliate, the final form of which is attached as Exhibit A (“Fee Agreement”), pursuant to which the County will provide certain incentives to the Sponsor with respect to the Project, including (i) providing for FILOT Payments, to be calculated as set forth in the Fee Agreement, with respect to the portion of the Project which constitutes economic development property; (ii) locating the Project in the Park; and (iii) providing Infrastructure Credits and other incentives, as described in the Fee Agreement, to assist in paying the costs of certain Infrastructure.

NOW THEREFORE, BE IT ORDAINED, by the County Council as follows:

Section 1. Statutory Findings. Based on information supplied to the County by the Sponsor, County Council evaluated the Project based on relevant criteria including, the purposes the Project is to accomplish, the anticipated dollar amount and nature of the investment, employment to be created and retained, and the anticipated costs and benefits to the County, and hereby finds:

(a) The Project is anticipated to benefit the general public welfare of the County by providing services, employment, recreation, or other public benefits not otherwise adequately provided locally;

(b) The Project gives rise to no pecuniary liability of the County or incorporated municipality or a charge against its general credit or taxing power;

(c) The purposes to be accomplished by the Project are proper governmental and public purposes and the benefits of the Project are greater than the costs.

Section 2. *Approval of Incentives; Authorization to Execute and Deliver Fee Agreement.* The incentives as described in this Ordinance (“Ordinance”), and as more particularly set forth in the Fee Agreement, with respect to the Project are hereby approved. The form, terms and provisions of the Fee Agreement that is before this meeting are approved and all of the Fee Agreement’s terms and conditions are incorporated in this Ordinance by reference. The Chair of County Council (“Chair”) is authorized and directed to execute the Fee Agreement in the name of and on behalf of the County, subject to the approval of any revisions or changes as are not materially adverse to the County by the County Administrator and counsel to the County, and the Clerk to County Council is hereby authorized and directed to attest the Fee Agreement and to deliver the Fee Agreement to the Sponsor.

Section 3. *Inclusion within the Park.* The expansion of the Park boundaries to include the Project is authorized and approved. The Chair, the County Administrator and the Clerk to County Council are each authorized to execute such documents and take such further actions as may be necessary to complete the expansion of the Park boundaries. Pursuant to the terms of the agreement governing the Park (“Park Agreement”), the expansion of the Park’s boundaries and the amendment to the Park Agreement is complete on adoption of this Ordinance by County Council and delivery of written notice to Fairfield County of the inclusion of the Project in the Park.

Section 4. *Grant Acceptance and Administration.* To the extent the County receives any third-party grant funds related to the Project, the County agrees to accept and administer those funds for the Project's benefit according to any documents governing the receipt and expenditure of the grant funds.

Section 5. *Further Assurances.* The County Council confirms the authority of the Chair, the County Administrator, the Director of Economic Development, the Clerk to County Council, and various other County officials and staff, acting at the direction of the Chair, the County Administrator, or the Director of Economic Development, as appropriate, to take whatever further action and for the Chair, the County Administrator, and the Director of Economic Development to negotiate, execute and deliver whatever further documents, and for the Clerk to County Council to attest the same, as may be appropriate to effect this Ordinance and the incentives offered to the Sponsor under this Ordinance and the Fee Agreement.

Section 6. *Savings Clause.* The provisions of this Ordinance are separable. If any part of this Ordinance is, for any reason, unenforceable then the validity of the remainder of this Ordinance is unaffected.

Section 7. *General Repealer.* Any prior ordinance, resolution, or order, the terms of which are in conflict with this Ordinance, is, only to the extent of that conflict, repealed.

Section 8. *Effectiveness.* This Ordinance is effective after its third reading and public hearing.

RICHLAND COUNTY, SOUTH CAROLINA

Chair, Richland County Council

(SEAL)
ATTEST:

Clerk of Council, Richland County Council

First Reading: November 1, 2022
Second Reading:
Public Hearing:
Third Reading:

EXHIBIT A
FORM OF FEE AGREEMENT

4875-1670-8663 v.6 005084/09040, 8:26 PM, 10/16/2022

FEE-IN-LIEU OF *AD VALOREM* TAXES AND INCENTIVE AGREEMENT

BETWEEN

PROJECT WELLNESS

AND

[PROPERTY HOLDING ENTITY]

AND

RICHLAND COUNTY, SOUTH CAROLINA

EFFECTIVE AS OF []



TABLE OF CONTENTS

	Page
Recitals.....	1
 ARTICLE I DEFINITIONS 	
Section 1.1 Terms.....	1
 ARTICLE II REPRESENTATIONS AND WARRANTIES 	
Section 2.1 Representations, Warranties, and Agreements of the County.....	4
Section 2.2 Representations, Warranties, and Agreements of the Sponsor.....	5
 ARTICLE III THE PROJECT 	
Section 3.1 The Project.....	5
Section 3.2 Leased Property.....	6
Section 3.3 Filings and Reports.....	6
 ARTICLE IV FILOT PAYMENTS 	
Section 4.1 FILOT Payments.....	6
Section 4.2 FILOT Payments on Replacement Property.....	7
Section 4.3 Removal of Components of the Project.....	7
Section 4.4 Damage or Destruction of Economic Development Property.....	7
Section 4.5 Condemnation.....	8
Section 4.6 Calculating FILOT Payments on Diminution in Value.....	8
Section 4.7 Payment of <i>Ad Valorem</i> Taxes.....	8
Section 4.8 Place of FILOT Payments.....	8
 ARTICLE V ADDITIONAL INCENTIVES 	
Section 5.1 Infrastructure Credits.....	9
 ARTICLE VI CLAW BACK 	
Section 6.1 Claw Back.....	9

ARTICLE VII
DEFAULT

Section 7.1 Events of Default 9
Section 7.2 Remedies on Default 10
Section 7.3 Reimbursement of Legal Fees and Other Expenses 10
Section 7.4 Remedies Not Exclusive 10

ARTICLE VIII
PARTICULAR COVENANTS AND AGREEMENTS

Section 8.1 Right to Inspect 10
Section 8.2 Confidentiality 10
Section 8.3 Indemnification Covenants 11
Section 8.4 No Liability of County’s Personnel 11
Section 8.5 Limitation of Liability 12
Section 8.6 Assignment 12
Section 8.7 No Double Payment; Future Changes in Legislation 12
Section 8.8 Administration Expenses 12

ARTICLE IX
SPONSOR AFFILIATES

Section 9.1 Sponsor Affiliates 12
Section 9.2 Primary Responsibility 13

ARTICLE X
MISCELLANEOUS

Section 10.1 Notices 13
Section 10.2 Provision of Agreement for Sole Benefit of County and Sponsor 13
Section 10.3 Counterparts 14
Section 10.4 Governing Law 14
Section 10.5 Headings 14
Section 10.6 Amendments 14
Section 10.7 Agreement to Sign Other Documents 14
Section 10.8 Interpretation; Invalidity; Change in Laws 14
Section 10.9 Force Majeure 14
Section 10.10 Termination; Termination by Sponsor 14
Section 10.11 Entire Agreement 15
Section 10.12 Waiver 15
Section 10.13 Business Day 15
Section 10.14 Agreement’s Construction 15

- Exhibit A – Description of Property
- Exhibit B – Form of Joinder Agreement
- Exhibit C – Accountability Resolution
- Exhibit D – Description of Infrastructure Credit
- Exhibit E – Description of Claw Back

**SUMMARY OF CONTENTS OF
FEE AGREEMENT**

The parties have agreed to waive the requirement to recapitulate the contents of this Fee Agreement pursuant to Section 12-44-55 of the Code (as defined herein). However, the parties have agreed to include a summary of the key provisions of this Fee Agreement for the convenience of the parties. This summary is included for convenience only and is not to be construed as a part of the terms and conditions of this Fee Agreement.

PROVISION	BRIEF DESCRIPTION	SECTION REFERENCE
Sponsor Name	Project Wellness	
Project Location		
Tax Map No.		
FILOT		
• Phase Exemption Period	30 Years	
• Contract Minimum Investment Requirement	\$81,078,275	
• Contract Minimum Jobs Requirement	94	
• Investment Period	10 years	
• Assessment Ratio	6%	
• Millage Rate	475.1	
• Fixed or Five-Year Adjustable Millage	Fixed	
• Claw Back Information	Statutory	
Multicounty Park	Richland – Fairfield	
Infrastructure Credit		
• Brief Description	Special Source Revenue Credit	
• Credit Term	50% years 1-5; 40% years 6-10	
• Claw Back Information	See Exhibit E	
Other Information		

FEE-IN-LIEU OF AD VALOREM TAXES AGREEMENT

THIS FEE-IN-LIEU OF AD VALOREM TAXES AGREEMENT (“*Fee Agreement*”) is entered into, effective, as of [DATE], between Richland County, South Carolina (“*County*”), a body politic and corporate and a political subdivision of the State of South Carolina (“*State*”), acting through the Richland County Council (“*County Council*”) as the governing body of the County, PROJECT WELLNESS, a [] organized and existing under the laws of the State of [] (“*Sponsor*”), and [], a [] organized and existing under the laws of the State of [] (“*Sponsor Affiliate Propco*”).

WITNESSETH:

(a) Title 12, Chapter 44, (“*Act*”) of the Code of Laws of South Carolina, 1976, as amended (“*Code*”), authorizes the County to induce manufacturing and commercial enterprises to locate in the State or to encourage manufacturing and commercial enterprises currently located in the State to expand their investments and thus make use of and employ the manpower, products, and other resources of the State by entering into an agreement with a sponsor, as defined in the Act, that provides for the payment of a fee-in-lieu of *ad valorem* tax (“*FILOT*”) with respect to Economic Development Property, as defined below;

(b) Sections 4-1-175 and 12-44-70 of the Code authorize the County to provide credits (“*Infrastructure Credit*”) against payments in lieu of taxes for the purpose of defraying of the cost of designing, acquiring, constructing, improving, or expanding (i) the infrastructure serving the County or a project and (ii) for improved and unimproved real estate, and personal property, including machinery and equipment, used in the operation of a manufacturing facility or commercial enterprise (collectively, “*Infrastructure*”);

(c) The Sponsor has committed to expand a manufacturing facility (“*Facility*”) in the County, consisting of taxable investment in real and personal property of not less than \$81,078,275 and the creation of 94 NEW, full-time jobs;

(d) By an ordinance enacted on [DATE], County Council authorized the County to enter into this Fee Agreement with the Sponsor to provide for a FILOT and the other incentives as more particularly described in this Fee Agreement to induce the Sponsor to expand its Facility in the County.

NOW, THEREFORE, AND IN CONSIDERATION of the respective representations and agreements hereinafter contained, the parties agree as follows:

ARTICLE I DEFINITIONS

Section 1.1. Terms. The defined terms used in this Fee Agreement have the meaning given below, unless the context clearly requires otherwise.

“*Act*” means Title 12, Chapter 44 of the Code, and all future acts successor or supplemental thereto or amendatory of this Fee Agreement.

“*Act Minimum Investment Requirement*” means an investment of at least \$2,500,000 in the Project within five years of the Commencement Date.

“*Administration Expenses*” means the reasonable expenses incurred by the County in the negotiation, approval and implementation of the terms and provisions of this Fee Agreement, including reasonable attorney’s and consultant’s fees. Administration Expenses does not include any costs, expenses, including attorney’s fees, incurred by the County (i) in defending challenges to the FILOT Payments, Infrastructure Credits or other incentives provided by this Fee Agreement brought by third parties or the

Sponsor or its affiliates and related entities, or (ii) in connection with matters arising at the request of the Sponsor outside of the immediate scope of this Fee Agreement, including amendments to the terms of this Fee Agreement.

“**Code**” means the Code of Laws of South Carolina, 1976, as amended.

“**Commencement Date**” means the last day of the property tax year during which the initial Economic Development Property is placed in service. The Commencement Date shall not be later than the last day of the property tax year which is three years from the year in which the County and the Sponsor enter into this Fee Agreement. For purposes of this Fee Agreement, the Commencement Date is expected to be December 31, 2022.

“**Contract Minimum Investment Requirement**” means a taxable investment in real and personal property at the Project of not less than \$81,078,275.

“**Contract Minimum Jobs Requirement**” means not less than 94 full-time, jobs created by the Sponsor in the County in connection with the Project over the Sponsor’s existing employment base as of 12/31/2021 which is 416 jobs.

“**County**” means Richland County, South Carolina, a body politic and corporate and a political subdivision of the State, its successors and assigns, acting by and through the County Council as the governing body of the County.

“**County Council**” means the Richland County Council, the governing body of the County.

“**Credit Term**” means the years during the Fee Term in which the Infrastructure Credit is applicable, as described in Exhibit C.

“**Department**” means the South Carolina Department of Revenue.

“**Diminution in Value**” means a reduction in the fair market value of Economic Development Property, as determined in Section 4.1(a)(i) of this Fee Agreement, which may be caused by (i) the removal or disposal of components of the Project pursuant to Section 4.3 of this Fee Agreement; (ii) a casualty as described in Section 4.4 of this Fee Agreement; or (iii) a condemnation as described in Section 4.5 of this Fee Agreement.

“**Economic Development Property**” means those items of real and tangible personal property of the Project placed in service not later than the end of the Investment Period that (i) satisfy the conditions of classification as economic development property under the Act, and (ii) are identified by the Sponsor in its annual filing of a PT-300S or comparable form with the Department (as such filing may be amended from time to time).

“**Equipment**” means all of the machinery, equipment, furniture, office equipment, and fixtures, together with any and all additions, accessions, replacements, and substitutions.

“**Event of Default**” means any event of default specified in Section 7.1 of this Fee Agreement.

“**Fee Agreement**” means this Fee-In-Lieu Of *Ad Valorem* Taxes and Incentive Agreement, as may be supplemented or amended.

“**Fee Term**” means the period from the effective date of this Fee Agreement until the Final Termination Date.

“**FILOT Payments**” means the amount paid or to be paid in lieu of *ad valorem* property taxes as provided in Section 4.1 of this Fee Agreement.

“**Final Phase**” means the Economic Development Property placed in service during the last year of the Investment Period.

“**Final Termination Date**” means the date on which the last FILOT Payment with respect to the Final Phase is made, or such earlier date as the Fee Agreement is terminated in accordance with the terms of this Fee Agreement. Assuming the Phase Termination Date for the Final Phase is [DATE], the Final Termination Date is expected to be [DATE], which is the due date of the last FILOT Payment with respect to the Final Phase.

“**Improvements**” means all improvements to the Real Property, including buildings, building additions, roads, sewer lines, and infrastructure, together with all additions, fixtures, accessions, replacements, and substitutions.

“**Infrastructure**” means (i) the infrastructure serving the County or the Project, (ii) improved and unimproved real estate, and personal property, including machinery and equipment, used in the operation of a manufacturing or commercial enterprise, or (iii) such other items as may be described in or permitted under Section 4-29-68 of the Code.

“**Infrastructure Credit**” means the credit provided to the Sponsor pursuant to Section 12-44-70 of the Act or Section 4-1-175 of the MCIP Act and Section 5.1 of this Fee Agreement, with respect to the Infrastructure. Infrastructure Credits are to be used for the payment of Infrastructure constituting real property, improvements and infrastructure before any use for the payment of Infrastructure constituting personal property, notwithstanding any presumptions to the contrary in the MCIP Act or otherwise.

“**Investment Period**” means the period beginning with the first day of any purchase or acquisition of Economic Development Property and ending ten (10) years after the Commencement Date, as extended pursuant to Section 12-44-30(13) of the Act. For purposes of this Fee Agreement, the Investment Period is expected to end on December 31, 2032.

“**MCIP Act**” means Article VIII, Section 13(D) of the Constitution of the State of South Carolina, and Sections 4-1-170, 4-1-172, 4-1-175, and 4-29-68 of the Code.

“**Multicounty Park**” means the multicounty industrial or business park governed by the Amended and Restated Master Agreement Governing the I-77 Corridor Regional Industrial Park, dated as of September 1, 2018 (as amended from time to time), between the County and Fairfield County, South Carolina, as may be amended.

“**Net FILOT Payment**” means the FILOT Payment net of the Infrastructure Credit.

“**Phase**” means the Economic Development Property placed in service during a particular year of the Investment Period.

“**Phase Exemption Period**” means, with respect to each Phase, the period beginning with the property tax year the Phase is placed in service during the Investment Period and ending on the Phase Termination Date.

“**Phase Termination Date**” means, with respect to each Phase, the last day of the property tax year which is the 29th year following the first property tax year in which the Phase is placed in service.

“**Project**” means all the Equipment, Improvements, and Real Property in the County that the Sponsor determines to be necessary, suitable, or useful by the Sponsor in connection with its investment in the County.

“**Real Property**” means real property that the Sponsor uses or will use in the County for the purposes that Section 2.2(b) describes, and initially consists of the land identified on Exhibit A of this Fee Agreement.

“**Removed Components**” means Economic Development Property which the Sponsor, in its sole discretion, (a) determines to be inadequate, obsolete, worn-out, uneconomic, damaged, unsuitable, undesirable, or unnecessary pursuant to Section 4.3 of this Fee Agreement or otherwise; or (b) elects to be treated as removed pursuant to Section 4.4(c) or Section 4.5(b)(iii) of this Fee Agreement.

“**Replacement Property**” means any property which is placed in service as a replacement for any Removed Component regardless of whether the Replacement Property serves the same functions as the Removed Component it is replacing and regardless of whether more than one piece of Replacement Property replaces a single Removed Component.

“**Sponsor**” means PROJECT WELLNESS and any surviving, resulting, or transferee entity in any merger, consolidation, or transfer of assets; or any other person or entity which may succeed to the rights and duties of the Sponsor under this Fee Agreement.

“**Sponsor Affiliate**” means an entity that participates in the investment or job creation at the Project and, following receipt of the County’s approval pursuant to Section 9.1 of this Fee Agreement, joins this Fee Agreement by delivering a Joinder Agreement, the form of which is attached as Exhibit B to this Fee Agreement.

“**State**” means the State of South Carolina.

Any reference to any agreement or document in this Article I or otherwise in this Fee Agreement shall include any and all amendments, supplements, addenda, and modifications to such agreement or document.

The term “investment” or “invest” as used in this Fee Agreement includes not only investments made by the Sponsor, but also to the fullest extent permitted by law, those investments made by or for the benefit of the Sponsor in connection with the Project through federal, state, or local grants, to the extent such investments are or, but for the terms of this Fee Agreement, would be subject to *ad valorem* taxes to be paid by the Sponsor.

ARTICLE II REPRESENTATIONS AND WARRANTIES

Section 2.1. Representations and Warranties of the County. The County represents and warrants as follows:

(a) The County is a body politic and corporate and a political subdivision of the State and acts through the County Council as its governing body. The Act authorizes and empowers the County to enter into the transactions that this Fee Agreement contemplates and to carry out its obligations under this Fee Agreement. The County has duly authorized the execution and delivery of this Fee Agreement and all other documents, certificates or other agreements contemplated in this Fee Agreement and has obtained all consents from third parties and taken all actions necessary or that the law requires to fulfill its obligations under this Fee Agreement.

(b) Based on representations by the Sponsor, County Council evaluated the Project based on all relevant criteria including the purposes the Project is to accomplish, the anticipated dollar amount and nature of the investment resulting from the Project, and the anticipated costs and benefits to the County and following the evaluation, the County determined that (i) the Project is anticipated to benefit the general public welfare of the County by providing services, employment, recreation, or other public benefits not otherwise adequately provided locally; (ii) the Project gives rise to no pecuniary liability of the County or any incorporated municipality and to no charge against the County's general credit or taxing power; (iii) the purposes to be accomplished by the Project are proper governmental and public purposes; and (iv) the benefits of the Project are greater than the costs.

(c) The County identified the Project, as a "project" on [DATE] by adopting an Inducement Resolution, as defined in the Act on [DATE].

(d) The County is not in default of any of its obligations (contractual or otherwise) as a result of entering into and performing its obligations under this Fee Agreement.

(e) The County has located or will take all reasonable action to locate the Project in the Multicounty Park.

Section 2.2. Representations and Warranties of the Sponsor. The Sponsor represents and warrants as follows:

(a) The Sponsor is in good standing under the laws of the state of its organization, is duly authorized to transact business in the State (or will obtain such authority prior to commencing business in the State), has power to enter into this Fee Agreement, and has duly authorized the execution and delivery of this Fee Agreement.

(b) The Sponsor intends to operate the Project as a manufacturing facility and for such other purposes that the Act permits as the Sponsor may deem appropriate.

(c) The Sponsor's execution and delivery of this Fee Agreement and its compliance with the provisions of this Fee Agreement do not result in a default under any agreement or instrument to which the Sponsor is now a party or by which it is bound.

(d) The Sponsor will use commercially reasonable efforts to achieve the Contract Minimum Investment Requirement and the Contract Minimum Jobs Requirement.

(e) The execution and delivery of this Fee Agreement by the County and the availability of the FILOT and other incentives provided by this Fee Agreement has been instrumental in inducing the Sponsor to locate the Project in the County.

(f) The Sponsor has retained legal counsel to confirm, or has had a reasonable opportunity to consult legal counsel to confirm, its eligibility for the FILOT and other incentives granted by this Fee Agreement and has not relied on the County, its officials, employees or legal representatives with respect to any question of eligibility or applicability of the FILOT and other incentives granted by this Fee Agreement.

ARTICLE III THE PROJECT

Section 3.1. The Project. The Sponsor intends and expects to (i) construct or acquire the Project and (ii) meet the Contract Minimum Investment Requirement and the Contract Minimum Jobs Requirement

within the Investment Period. The Sponsor anticipates that the first Phase of the Project will be placed in service during the calendar year ending December 31, 2022. Notwithstanding anything contained in this Fee Agreement to the contrary, the Sponsor is not obligated to complete the acquisition of the Project. However, if the Contract Minimum Investment Requirement is not met, the benefits provided to the Sponsor, or Sponsor Affiliate, if any, pursuant to this Fee Agreement may be reduced, modified or terminated as provided in this Fee Agreement.

Section 3.2 Leased Property. To the extent that State law allows or is revised or construed to permit leased assets including a building, or personal property to be installed in a building, to constitute Economic Development Property, then any property leased by the Sponsor is, at the election of the Sponsor, deemed to be Economic Development Property for purposes of this Fee Agreement, subject, at all times, to the requirements of State law and this Fee Agreement with respect to property comprising Economic Development Property.

Section 3.3. Filings and Reports.

(a) On or before January 31 of each year during the term of this Fee Agreement, commencing in the calendar year following the Commencement Date, 2024, the Sponsor shall deliver to the Economic Development Director of the County with respect to the Sponsor and all Sponsor Affiliates, if any, the information required by the terms of the County’s Resolution dated December 12, 2017, which is attached hereto as Exhibit C, as may be amended by subsequent resolution.

(b) The Sponsor shall file a copy of this Fee Agreement and a completed PT-443 with the Economic Development Director and the Department and the Auditor, Treasurer and Assessor of the County and partner county to the Multicounty Park.

(c) On request by the County Administrator or the Economic Development Director, the Sponsor shall remit to the Economic Development Director records accounting for the acquisition, financing, construction, and operation of the Project which records (i) permit ready identification of all Economic Development Property; (ii) confirm the dates that the Economic Development Property or Phase was placed in service; and (iii) include copies of all filings made in accordance with this Section.

**ARTICLE IV
FILOT PAYMENTS**

Section 4.1. FILOT Payments.

(a) The FILOT Payment due with respect to each Phase through the Phase Termination Date is calculated as follows:

- (i) The fair market value of the Phase calculated as set forth in the Act (for the Real Property and Improvements portion of the Phase, the County and the Sponsor have elected to [use the fair market value established in the first year of the Phase Exemption Period), multiplied by
- (ii) An assessment ratio of six percent (6%), multiplied by
- (iii) A fixed millage rate equal to 0.4751, which the parties believe is the cumulative millage rate levied by or on behalf of all the taxing entities within which the Project is located as of June 30, 2022.

The calculation of the FILOT Payment must allow all applicable property tax exemptions except those excluded pursuant to Section 12-44-50(A)(2) of the Act. The Sponsor acknowledges that (i) the calculation of the annual FILOT Payment is a function of the Department and is wholly dependent on the Sponsor timely submitting the correct annual property tax returns to the Department, (ii) the County has no responsibility for the submission of returns or the calculation of the annual FILOT Payment, and (iii) failure by the Sponsor to submit the correct annual property tax return could lead to a loss of all or a portion of the FILOT and other incentives provided by this Fee Agreement.

(b) If a final order of a court of competent jurisdiction from which no further appeal is allowable declares the FILOT Payments invalid or unenforceable, in whole or in part, for any reason, the parties shall negotiate the reformation of the calculation of the FILOT Payments to most closely afford the Sponsor with the intended benefits of this Fee Agreement. If such order has the effect of subjecting the Economic Development Property to *ad valorem* taxation, this Fee Agreement shall terminate, and the Sponsor shall owe the County regular *ad valorem* taxes from the date of termination, in accordance with Section 4.7 of this Fee Agreement.

Section 4.2. FILOT Payments on Replacement Property. If the Sponsor elects to place Replacement Property in service, then, pursuant and subject to the provisions of Section 12-44-60 of the Act, the Sponsor shall make the following payments to the County with respect to the Replacement Property for the remainder of the Phase Exemption Period applicable to the Removed Component of the Replacement Property:

(a) FILOT Payments, calculated in accordance with Section 4.1 of this Fee Agreement, on the Replacement Property to the extent of the original income tax basis of the Removed Component the Replacement Property is deemed to replace.

(b) Regular *ad valorem* tax payments to the extent the income tax basis of the Replacement Property exceeds the original income tax basis of the Removed Component the Replacement Property is deemed to replace.

Section 4.3. Removal of Components of the Project. Subject to the other terms and provisions of this Fee Agreement, the Sponsor is entitled to remove and dispose of components of the Project in its sole discretion. Components of the Project are deemed removed when scrapped, sold or otherwise removed from the Project. If the components removed from the Project are Economic Development Property, then the Economic Development Property is a Removed Component, no longer subject to this Fee Agreement and is subject to *ad valorem* property taxes to the extent the Removed Component remains in the State and is otherwise subject to *ad valorem* property taxes.

Section 4.4. Damage or Destruction of Economic Development Property.

(a) *Election to Terminate.* If Economic Development Property is damaged by fire, explosion, or any other casualty, then the Sponsor may terminate this Fee Agreement. For the property tax year corresponding to the year in which the damage or casualty occurs, the Sponsor is obligated to make FILOT Payments with respect to the damaged Economic Development Property only to the extent property subject to *ad valorem* taxes would have been subject to *ad valorem* taxes under the same circumstances for the period in question.

(b) *Election to Restore and Replace.* If Economic Development Property is damaged by fire, explosion, or any other casualty, and the Sponsor does not elect to terminate this Fee Agreement, then the Sponsor may restore and replace the Economic Development Property. All restorations and replacements made pursuant to this subsection (b) are deemed, to the fullest extent permitted by law and this Fee Agreement, to be Replacement Property.

(c) *Election to Remove.* If Economic Development Property is damaged by fire, explosion, or any other casualty, and the Sponsor elects not to terminate this Fee Agreement pursuant to subsection (a) and elects not to restore or replace pursuant to subsection (b), then the damaged portions of the Economic Development Property are deemed Removed Components.

Section 4.5. Condemnation.

(a) *Complete Taking.* If at any time during the Fee Term title to or temporary use of the Economic Development Property is vested in a public or quasi-public authority by virtue of the exercise of a taking by condemnation, inverse condemnation, or the right of eminent domain; by voluntary transfer under threat of such taking; or by a taking of title to a portion of the Economic Development Property which renders continued use or occupancy of the Economic Development Property commercially unfeasible in the judgment of the Sponsor, the Sponsor shall have the option to terminate this Fee Agreement by sending written notice to the County within a reasonable period of time following such vesting.

(b) *Partial Taking.* In the event of a partial taking of the Economic Development Property or a transfer in lieu, the Sponsor may elect: (i) to terminate this Fee Agreement; (ii) to restore and replace the Economic Development Property, with such restorations and replacements deemed, to the fullest extent permitted by law and this Fee Agreement, to be Replacement Property; or (iii) to treat the portions of the Economic Development Property so taken as Removed Components.

(c) In the year in which the taking occurs, the Sponsor is obligated to make FILOT Payments with respect to the Economic Development Property so taken only to the extent property subject to *ad valorem* taxes would have been subject to taxes under the same circumstances for the period in question.

Section 4.6. Calculating FILOT Payments on Diminution in Value. If there is a Diminution in Value, the FILOT Payments due with respect to the Economic Development Property or Phase so diminished shall be calculated by substituting the diminished value of the Economic Development Property or Phase for the original fair market value in Section 4.1(a)(i) of this Fee Agreement.

Section 4.7. Payment of Ad Valorem Taxes. If Economic Development Property becomes subject to *ad valorem* taxes as imposed by law pursuant to the terms of this Fee Agreement or the Act, then the calculation of the *ad valorem* taxes due with respect to the Economic Development Property in a particular property tax year shall: (i) include the property tax reductions that would have applied to the Economic Development Property if it were not Economic Development Property; and (ii) include a credit for FILOT Payments the Sponsor has made with respect to the Economic Development Property.

Section 4.8. Place of FILOT Payments. All FILOT Payments shall be made directly to the County in accordance with applicable law.

**ARTICLE V
ADDITIONAL INCENTIVES**

Section 5.1. Infrastructure Credits. To assist in paying for costs of Infrastructure, the Sponsor is entitled to claim an Infrastructure Credit to reduce certain FILOT Payments due and owing from the Sponsor to the County under this Fee Agreement. The term, amount and calculation of the Infrastructure Credit is described in Exhibit D. In no event may the Sponsor's aggregate Infrastructure Credit claimed pursuant to this Section exceed the aggregate expenditures by the Sponsor on Infrastructure.

For each property tax year in which the Infrastructure Credit is applicable ("**Credit Term**"), the County shall prepare and issue the annual bills with respect to the Project showing the Net FILOT Payment, calculated in accordance with Exhibit D. Following receipt of the bill, the Sponsor shall timely remit the Net FILOT Payment to the County in accordance with applicable law.

**ARTICLE VI
CLAW BACK**

Section 6.1. Claw Back. If the Sponsor fails to perform its obligations under this Fee Agreement as described in Exhibit E, then the Sponsor is subject to the claw backs as described in Exhibit E. Any amount that may be due from the Sponsor to the County as calculated in accordance with or described in Exhibit E is due within 30 days of receipt of a written statement from the County. If not timely paid, the amount due from the Sponsor to the County is subject to the minimum amount of interest that the law may permit with respect to delinquent *ad valorem* tax payments. The repayment obligation arising under this Section and Exhibit E survives termination of this Fee Agreement.

**ARTICLE VII
DEFAULT**

Section 7.1. Events of Default. The following are "Events of Default" under this Fee Agreement:

(a) Failure to make FILOT Payments, which failure has not been cured within 30 days following receipt of written notice from the County specifying the delinquency in FILOT Payments and requesting that it be remedied;

(b) Failure to timely pay any amount, except FILOT Payments, due under this Fee Agreement;

(c) A Cessation of Operations. For purposes of this Fee Agreement, a "**Cessation of Operations**" means a publicly announced closure of the Facility, a layoff of a majority of the employees working at the Facility, or a substantial reduction in production that continues for a period of twelve (12) months;

(d) A representation or warranty made by the Sponsor which is deemed materially incorrect when deemed made;

(e) Failure by the Sponsor to perform any of the terms, conditions, obligations, or covenants under this Fee Agreement (other than those under (a), above), which failure has not been cured within 30 days after written notice from the County to the Sponsor specifying such failure and requesting that it be remedied, unless the Sponsor has instituted corrective action within the 30-day period and is diligently pursuing corrective action until the default is corrected, in which case the 30-day period is extended to include the period during which the Sponsor is diligently pursuing corrective action;

(f) A representation or warranty made by the County which is deemed materially incorrect when deemed made; or

(g) Failure by the County to perform any of the terms, conditions, obligations, or covenants hereunder, which failure has not been cured within 30 days after written notice from the Sponsor to the County specifying such failure and requesting that it be remedied, unless the County has instituted corrective action within the 30-day period and is diligently pursuing corrective action until the default is corrected, in which case the 30-day period is extended to include the period during which the County is diligently pursuing corrective action.

Section 7.2. Remedies on Default.

(a) If an Event of Default by the Sponsor has occurred and is continuing, then the County may take any one or more of the following remedial actions:

(i) terminate this Fee Agreement; or

(ii) take whatever action at law or in equity may appear necessary or desirable to collect amounts due or otherwise remedy the Event of Default or recover its damages.

(b) If an Event of Default by the County has occurred and is continuing, the Sponsor may take any one or more of the following actions:

(i) bring an action for specific enforcement;

(ii) terminate this Fee Agreement; or

(iii) in case of a materially incorrect representation or warranty, take such action as is appropriate, including legal action, to recover its damages, to the extent allowed by law.

Section 7.3. Reimbursement of Legal Fees and Other Expenses. On the occurrence of an Event of Default, if a party is required to employ attorneys or incur other reasonable expenses for the collection of payments due under this Fee Agreement or for the enforcement of performance or observance of any obligation or agreement, the prevailing party is entitled to seek reimbursement of the reasonable fees of such attorneys and such other reasonable expenses so incurred.

Section 7.4. Remedies Not Exclusive. Except for the remedy described on Exhibit E, no remedy described in this Fee Agreement is intended to be exclusive of any other remedy or remedies, and each and every such remedy is cumulative and in addition to every other remedy given under this Fee Agreement or existing at law or in equity or by statute.

**ARTICLE VIII
PARTICULAR RIGHTS AND COVENANTS**

Section 8.1. Right to Inspect. The County and its authorized agents, at any reasonable time on prior written notice (which may be given by email), may enter and examine and inspect the Project for the purposes of permitting the County to carry out its duties and obligations in its sovereign capacity (such as, without limitation, for such routine health and safety purposes as would be applied to any other manufacturing or commercial facility in the County).

Section 8.2. Confidentiality. The County acknowledges that the Sponsor may utilize confidential and proprietary processes and materials, services, equipment, trade secrets, and techniques (“*Confidential*

Information”) and that disclosure of the Confidential Information could result in substantial economic harm to the Sponsor. The Sponsor may clearly label any Confidential Information delivered to the County pursuant to this Fee Agreement as “*Confidential Information*.” Except as required by law, the County, or any employee, agent, or contractor of the County, shall not disclose or otherwise divulge any labeled Confidential Information to any other person, firm, governmental body or agency. The Sponsor acknowledges that the County is subject to the South Carolina Freedom of Information Act, and, as a result, must disclose certain documents and information on request, absent an exemption. If the County is required to disclose any Confidential Information to a third party, the County will use its best efforts to provide the Sponsor with as much advance notice as is reasonably possible of such disclosure requirement prior to making such disclosure, and to cooperate reasonably with any attempts by the Sponsor to obtain judicial or other relief from such disclosure requirement.

Section 8.3. Indemnification Covenants.

(a) Except as provided in paragraph (d) below, the Sponsor shall indemnify and save the County, its employees, elected officials, officers and agents (each, an “*Indemnified Party*”) harmless against and from all liability or claims arising from the County’s execution of this Fee Agreement, performance of the County’s obligations under this Fee Agreement or the administration of its duties pursuant to this Fee Agreement, or otherwise by virtue of the County having entered into this Fee Agreement.

(b) The County is entitled to use counsel of its choice and the Sponsor shall reimburse the County for all of its costs, including attorneys’ fees, incurred in connection with the response to or defense against such liability or claims as described in paragraph (a), above. The County shall provide a statement of the costs incurred in the response or defense, and the Sponsor shall pay the County within 30 days of receipt of the statement. The Sponsor may request reasonable documentation evidencing the costs shown on the statement. However, the County is not required to provide any such documentation which may be privileged or confidential to evidence the costs.

(c) The County may request the Sponsor to resist or defend against any claim on behalf of an Indemnified Party. On such request, the Sponsor shall resist or defend against such claim on behalf of the Indemnified Party, at the Sponsor’s expense. The Sponsor is entitled to use counsel of its choice, manage and control the defense of or response to such claim for the Indemnified Party; provided the Sponsor is not entitled to settle any such claim without the consent of that Indemnified Party.

(d) Notwithstanding anything in this Section or this Fee Agreement to the contrary, the Sponsor is not required to indemnify any Indemnified Party against or reimburse any Indemnified Party for costs arising from any claim or liability (i) occasioned by the acts of that Indemnified Party, which are unrelated to the execution of this Fee Agreement, performance of the County’s obligations under this Fee Agreement, or the administration of its duties under this Fee Agreement, or otherwise by virtue of the County having entered into this Fee Agreement; or (ii) resulting from that Indemnified Party’s own negligence, bad faith, fraud, deceit, or willful misconduct.

(e) An Indemnified Party may not avail itself of the indemnification or reimbursement of costs provided in this Section unless it provides the Sponsor with prompt notice, reasonable under the circumstances, of the existence or threat of any claim or liability, including, without limitation, copies of any citations, orders, fines, charges, remediation requests, or other claims or threats of claims, in order to afford the Sponsor notice, reasonable under the circumstances, within which to defend or otherwise respond to a claim.

(f) The obligations under this Section 8.3 shall survive termination of this Fee Agreement.

Section 8.4. No Liability of County Personnel. All covenants, stipulations, promises, agreements and obligations of the County contained in this Fee Agreement are binding on members of the County Council or any elected official, officer, agent, servant or employee of the County only in his or her official capacity and not in his or her individual capacity, and no recourse for the payment of any moneys under this Fee Agreement may be had against any member of County Council or any elected or appointed official, officer, agent, servant or employee of the County and no recourse for the payment of any moneys or performance of any of the covenants and agreements under this Fee Agreement or for any claims based on this Fee Agreement may be had against any member of County Council or any elected or appointed official, officer, agent, servant or employee of the County except solely in their official capacity.

Section 8.5. Limitation of Liability. The County is not liable to the Sponsor for any costs, expenses, losses, damages, claims or actions in connection with this Fee Agreement, except from amounts received by the County from the Sponsor under this Fee Agreement. Notwithstanding anything in this Fee Agreement to the contrary, any financial obligation the County may incur under this Fee Agreement is deemed not to constitute a pecuniary liability or a debt or general obligation of the County.

Section 8.6. Assignment. The Sponsor may assign this Fee Agreement in whole or in part with the prior written consent of the County or a subsequent written ratification by the County, which may be done by resolution, and which consent or ratification the County will not unreasonably withhold. The Sponsor agrees to notify the County and the Department of the identity of the proposed transferee within 60 days of the transfer. In case of a transfer, the transferee assumes the transferor's basis in the Economic Development Property for purposes of calculating the FILOT Payments.

Section 8.7. No Double Payment; Future Changes in Legislation. Notwithstanding anything contained in this Fee Agreement to the contrary, and except as expressly required by law, the Sponsor is not required to make a FILOT Payment in addition to a regular *ad valorem* property tax payment in the same year with respect to the same piece of Economic Development Property. The Sponsor is not required to make a FILOT Payment on Economic Development Property in cases where, absent this Fee Agreement, *ad valorem* property taxes would otherwise not be due on such property.

Section 8.8. Administration Expenses. The Sponsor will reimburse, or cause reimbursement to, the County for Administration Expenses in the amount of \$[]. The Sponsor will reimburse the County for its Administration Expenses on receipt of a written request from the County or at the County's direction, which request shall include a statement of the amount and nature of the Administration Expense. The Sponsor shall pay the Administration Expense as set forth in the written request no later than 60 days following receipt of the written request from the County. The County does not impose a charge in the nature of impact fees or recurring fees in connection with the incentives authorized by this Fee Agreement. The payment by the Sponsor of the County's Administration Expenses shall not be construed as prohibiting the County from engaging, at its discretion, the counsel of the County's choice.

ARTICLE IX SPONSOR AFFILIATES

Section 9.1. Sponsor Affiliates. The Sponsor may designate Sponsor Affiliates from time to time, including at the time of execution of this Fee Agreement, pursuant to and subject to the provisions of Section 12-44-130 of the Act. To designate a Sponsor Affiliate, the Sponsor must deliver written notice to the Economic Development Director identifying the Sponsor Affiliate and requesting the County's approval of the Sponsor Affiliate. Except with respect to a Sponsor Affiliate designated at the time of execution of this Fee Agreement, which may be approved in the County Council ordinance authorizing the execution and delivery of this Fee Agreement, approval of the Sponsor Affiliate may be given by the County Administrator delivering written notice to the Sponsor and Sponsor Affiliate following receipt by the County Administrator of a recommendation from the Economic Development Committee of County

Council to allow the Sponsor Affiliate to join in the investment at the Project. The Sponsor Affiliate's joining in the investment at the Project will be effective on delivery of a Joinder Agreement, the form of which is attached as Exhibit B, executed by the Sponsor Affiliate to the County. Sponsor Affiliate Propco is hereby approved as a Sponsor Affiliate.

Section 9.2. Primary Responsibility. Notwithstanding the addition of a Sponsor Affiliate, the Sponsor acknowledges that it has the primary responsibility for the duties and obligations of the Sponsor and any Sponsor Affiliate under this Fee Agreement, including the payment of FILOT Payments or any other amount due to or for the benefit of the County under this Fee Agreement. For purposes of this Fee Agreement, "primary responsibility" means that if the Sponsor Affiliate fails to make any FILOT Payment or remit any other amount due under this Fee Agreement, the Sponsor shall make such FILOT Payments or remit such other amounts on behalf of the Sponsor Affiliate.

**ARTICLE X
MISCELLANEOUS**

Section 10.1. Notices. Any notice, election, demand, request, or other communication to be provided under this Fee Agreement is effective when delivered to the party named below or when deposited with the United States Postal Service, certified mail, return receipt requested, postage prepaid, addressed as follows (or addressed to such other address as any party shall have previously furnished in writing to the other party), except where the terms of this Fee Agreement require receipt rather than sending of any notice, in which case such provision shall control:

IF TO THE SPONSOR:

PROJECT WELLNESS

WITH A COPY TO (does not constitute notice):

Nelson Mullins Riley & Scarborough, LLP
Attn: Edward G. Kluiters
1320 Main Street, 17th Floor
Columbia, South Carolina 29201

IF TO THE COUNTY:

Richland County, South Carolina
Attn: Richland County Economic Development Director
2020 Hampton Street
Columbia, South Carolina 29204

WITH A COPY TO (does not constitute notice):

Parker Poe Adams & Bernstein LLP
Attn: Ray E. Jones
1221 Main Street, Suite 1100 (29201)
Post Office Box 1509
Columbia, South Carolina 29202-1509

Section 10.2. Provisions of Agreement for Sole Benefit of County and Sponsor. Except as otherwise specifically provided in this Fee Agreement, nothing in this Fee Agreement expressed or implied confers on any person or entity other than the County and the Sponsor any right, remedy, or claim under or by reason of this Fee Agreement, this Fee Agreement being intended to be for the sole and exclusive benefit of the County and the Sponsor.

Section 10.3. Counterparts. This Fee Agreement may be executed in any number of counterparts, and all of the counterparts together constitute one and the same instrument.

Section 10.4. Governing Law. South Carolina law, exclusive of its conflicts of law provisions that would refer the governance of this Fee Agreement to the laws of another jurisdiction, governs this Fee Agreement and all documents executed in connection with this Fee Agreement.

Section 10.5. Headings. The headings of the articles and sections of this Fee Agreement are inserted for convenience only and do not constitute a part of this Fee Agreement.

Section 10.6. Amendments. This Fee Agreement may be amended only by written agreement of the parties to this Fee Agreement.

Section 10.7. Agreement to Sign Other Documents. From time to time, and at the expense of the Sponsor, to the extent any expense is incurred, the County agrees to execute and deliver to the Sponsor such additional instruments as the Sponsor may reasonably request and as are authorized by law and reasonably within the purposes and scope of the Act and this Fee Agreement to effectuate the purposes of this Fee Agreement.

Section 10.8. Interpretation; Invalidity; Change in Laws.

(a) If the inclusion of property as Economic Development Property or any other issue is unclear under this Fee Agreement, then the parties intend that the interpretation of this Fee Agreement be done in a manner that provides for the broadest inclusion of property under the terms of this Fee Agreement and the maximum incentive permissible under the Act, to the extent not inconsistent with any of the explicit terms of this Fee Agreement.

(b) If any provision of this Fee Agreement is declared illegal, invalid, or unenforceable for any reason, the remaining provisions of this Fee Agreement are unimpaired, and the parties shall reform such illegal, invalid, or unenforceable provision to effectuate most closely the legal, valid, and enforceable intent of this Fee Agreement so as to afford the Sponsor with the maximum benefits to be derived under this Fee Agreement, it being the intention of the County to offer the Sponsor the strongest inducement possible, within the provisions of the Act, to locate the Project in the County.

(c) The County agrees that in case the FILOT incentive described in this Fee Agreement is found to be invalid and the Sponsor does not realize the economic benefit it is intended to receive from the County under this Fee Agreement as an inducement to locate in the County, the County agrees to negotiate with the Sponsor to provide a special source revenue or Infrastructure Credit to the Sponsor (in addition to the Infrastructure Credit explicitly provided for above) to the maximum extent permitted by law, to allow the Sponsor to recoup all or a portion of the loss of the economic benefit resulting from such invalidity.

Section 10.9. Force Majeure. The Sponsor is not responsible for any delays or non-performance caused in whole or in part, directly or indirectly, by strikes, accidents, freight embargoes, fires, floods, inability to obtain materials, conditions arising from governmental orders or regulations, war or national emergency, acts of God, and any other cause, similar or dissimilar, beyond the Sponsor's reasonable control.

Section 10.10. Termination; Termination by Sponsor.

(a) Unless first terminated under any other provision of this Fee Agreement, this Fee Agreement terminates on the Final Termination Date.

(b) The Sponsor is authorized to terminate this Fee Agreement at any time with respect to all or part of the Project on providing the County with 30 days' notice.

(c) Any monetary obligations due and owing at the time of termination and any provisions which are intended to survive termination, including specifically the obligations arising under Section 8.3 of this Fee Agreement, survive such termination.

(d) In the year following termination, all Economic Development Property is subject to *ad valorem* taxation or such other taxation or payment in lieu of taxation that would apply absent this Fee Agreement. The Sponsor's obligation to make FILOT Payments under this Fee Agreement terminates to the extent of and in the year following the year the Sponsor terminates this Fee Agreement pursuant to this Section.

Section 10.11. Entire Agreement. This Fee Agreement expresses the entire understanding and all agreements of the parties, and neither party is bound by any agreement or any representation to the other party which is not expressly set forth in this Fee Agreement or in certificates delivered in connection with the execution and delivery of this Fee Agreement.

Section 10.12. Waiver. Either party may waive compliance by the other party with any term or condition of this Fee Agreement only in a writing signed by the waiving party.

Section 10.13. Business Day. If any action, payment, or notice is, by the terms of this Fee Agreement, required to be taken, made, or given on any Saturday, Sunday, or legal holiday in the jurisdiction in which the party obligated to act is situated, such action, payment, or notice may be taken, made, or given on the following business day with the same effect as if taken, made or given as required under this Fee Agreement, and no interest will accrue in the interim.

Section 10.14. Agreement's Construction. Each party and its counsel have reviewed this Fee Agreement and any rule of construction to the effect that ambiguities are to be resolved against a drafting party does not apply in the interpretation of this Fee Agreement or any amendments or exhibits to this Fee Agreement.

[Signature pages follow]

IN WITNESS WHEREOF, the County, acting by and through the County Council, has caused this Fee Agreement to be executed in its name and on its behalf by the Chair of County Council and to be attested by the Clerk of the County Council; and the Sponsor has caused this Fee Agreement to be executed by its duly authorized officer, all as of the day and year first above written.

RICHLAND COUNTY, SOUTH CAROLINA

(SEAL)

By: _____
County Council Chair
Richland County, South Carolina

ATTEST:

By: _____
Clerk to County Council
Richland County, South Carolina

[Signature Page 1 to Fee in Lieu of Ad Valorem Taxes and Incentive Agreement]

PROJECT WELLNESS

By: _____
Its: _____

SPONSOR AFFILIATE PROPCO

By: _____
Its: _____

[Signature Page 2 to Fee in Lieu of Ad Valorem Taxes and Incentive Agreement]

EXHIBIT A
PROPERTY DESCRIPTION

EXHIBIT B (see Section 9.1)
FORM OF JOINDER AGREEMENT

Reference is hereby made to the Fee-in-Lieu of *Ad Valorem* Taxes Agreement, effective [DATE] (“Fee Agreement”), between Richland County, South Carolina (“County”) and [COMPANY] (“Sponsor”).

1. Joinder to Fee Agreement.

[_____], a [STATE] [corporation]/[limited liability company]/[limited partnership] authorized to conduct business in the State of South Carolina, hereby (a) joins as a party to, and agrees to be bound by and subject to all of the terms and conditions of, the Fee Agreement as if it were a Sponsor [except the following: _____]; (b) shall receive the benefits as provided under the Fee Agreement with respect to the Economic Development Property placed in service by the Sponsor Affiliate as if it were a Sponsor [except the following _____]; (c) acknowledges and agrees that (i) according to the Fee Agreement, the undersigned has been designated as a Sponsor Affiliate by the Sponsor for purposes of the Project; and (ii) the undersigned qualifies or will qualify as a Sponsor Affiliate under the Fee Agreement and Section 12-44-30(20) and Section 12-44-130 of the Act.

2. Capitalized Terms.

Each capitalized term used, but not defined, in this Joinder Agreement has the meaning of that term set forth in the Fee Agreement.

3. Representations of the Sponsor Affiliate.

The Sponsor Affiliate represents and warrants to the County as follows:

(a) The Sponsor Affiliate is in good standing under the laws of the state of its organization, is duly authorized to transact business in the State (or will obtain such authority prior to commencing business in the State), has power to enter into this Joinder Agreement, and has duly authorized the execution and delivery of this Joinder Agreement.

(b) The Sponsor Affiliate’s execution and delivery of this Joinder Agreement, and its compliance with the provisions of this Joinder Agreement, do not result in a default, not waived or cured, under any agreement or instrument to which the Sponsor Affiliate is now a party or by which it is bound.

(c) The execution and delivery of this Joinder Agreement and the availability of the FILOT and other incentives provided by this Joinder Agreement has been instrumental in inducing the Sponsor Affiliate to join with the Sponsor in the Project in the County.

4. Governing Law.

This Joinder Agreement is governed by and construed according to the laws, without regard to principles of choice of law, of the State of South Carolina.

5. Notice.

Notices under Section 10.1 of the Fee Agreement shall be sent to:

[_____]

IN WITNESS WHEREOF, the undersigned has executed this Joinder Agreement to be effective as of the date set forth below.

Date

Name of Entity
By: _____
Its: _____

IN WITNESS WHEREOF, the County acknowledges it has consented to the addition of the above-named entity as a Sponsor Affiliate under the Fee Agreement effective as of the date set forth above.

RICHLAND COUNTY, SOUTH CAROLINA

By: _____
Its: _____

EXHIBIT C (see Section 3.3)
RICHLAND COUNTY RESOLUTION REQUIRING CERTAIN ACCOUNTABILITY PRACTICES CONCERNING
ECONOMIC DEVELOPMENT PROJECTS IN THE COUNTY

**A RESOLUTION TO AMEND THE DECEMBER 21, 2010,
RESOLUTION REQUIRING CERTAIN ACCOUNTABILITY
PRACTICES CONCERNING ECONOMIC DEVELOPMENT
PROJECTS IN RICHLAND COUNTY**

WHEREAS, Richland County Council adopted a resolution dated as of December 21, 2010 (“Prior Resolution”), which requires companies receiving economic development incentives from Richland County, South Carolina (“County”) to submit annual reports to the Richland County Economic Development Office; and

WHEREAS, the County desires to make the form of the annual reports submitted by such companies uniform in order to make the substantive information contained in the annual reports more easily tracked and documented by the Richland County Economic Development Office.

NOW, THEREFORE, BE IT RESOLVED by Richland County Council as follows:

Section 1. The County affirms that each company awarded an incentive by the County in exchange for the location or expansion of a facility or facilities within the County shall submit an annual report to the Richland County Economic Development Office by January 31 of each year throughout the term of the incentives.

Section 2. The Richland County Economic Development Office is authorized to create (and from time to time, if necessary, amend or recreate) and make available the form of the annual report; however, such form, shall require, at a minimum, the following information:

- a. Name of company;
- b. Cumulative capital investment (less any removed investment) to date as a result of the project;
- c. Net jobs created to date as a result of the project;

Section 3. A copy of the then-current form of the annual report may be obtained from the following address. The annual report shall likewise be submitted to the following address by the required date.

Richland County Economic Development Office
Attention: Kim Mann
1201 Main Street, Suite 910
Columbia, SC 29201

Section 4. This Resolution amends the Prior Resolution and sets forth the County’s requirements with respect to the annual reports to be submitted by each company awarded an incentive by the County as described in Section 1.

Section 5. The substance of this Resolution shall be incorporated into the agreement between the County and each company with respect to the incentives granted by the County to the company.

Section 6. In the event that any company shall fail to submit an annual report, or any portion thereof, such company may be required to return all incentives, or a dollar amount equal thereof, to the County. Such incentives, or the dollar amount equal thereto, shall be paid to the County within 60 days after the date upon which the information was originally due.

RESOLVED: December 12 2017

RICHLAND COUNTY, SOUTH CAROLINA



Chair, Richland County Council

(SEAL)
ATTEST:



Clerk to County Council

EXHIBIT D (see Section 5.1)
DESCRIPTION OF INFRASTRUCTURE CREDIT

The Company is entitled to claim an Infrastructure Credit against its FILOT Payments for a period of 10 years, commencing with the first FILOT Payment due with respect to the Project. The Infrastructure Credit is equal to 50% of the FILOT Payment in years 1-5 of the Credit Term and 40% of the FILOT Payment in years 6-10 of the Credit Term.

EXHIBIT E (see Section 6.1)
DESCRIPTION OF CLAW BACK

If the Sponsor fails to achieve the Contract Minimum Investment Requirement or at least 80% of the Contract Minimum Jobs Requirement, a claw back shall be used as follows:

$$\text{Repayment Amount} = \text{Total Received} \times \text{Claw Back Percentage}$$

$$\text{Claw Back Percentage} = 100\% - \text{Overall Achievement Percentage}$$

$$\text{Overall Achievement Percentage} = (\text{Investment Achievement Percentage} + \text{Jobs Achievement Percentage}) / 2$$

$$\text{Investment Achievement Percentage} = \text{Actual Investment Achieved} / \text{Contract Minimum Investment Requirement} \text{ [may not exceed 100\%]}$$

$$\text{Jobs Achievement Percentage} = \text{Actual New, Full-Time Jobs Created} / \text{Contract Minimum Jobs Requirement} \text{ [may not exceed 100\%]}$$

In calculating the each achievement percentage, only the investment made or new jobs achieved up to the Contract Minimum Investment Requirement and the Contract Minimum Jobs Requirement will be counted.

For example, and by way of example only, if the County granted \$100,000 in Infrastructure Credits, and \$72,970,447 had been invested at the Project and 90 jobs had been created by the end of the Investment Period, the Repayment Amount would be calculated as follows:

$$\text{Jobs Achievement Percentage} = 66/94 = 70\%$$

$$\text{Investment Achievement Percentage} = \$72,970,447 / \$81,078,275 = 90\%$$

$$\text{Overall Achievement Percentage} = (70\% + 90\%) / 2 = 80\%$$

$$\text{Claw Back Percentage} = 100\% - 80\% = 20\%$$

$$\text{Repayment Amount} = \$100,000 \times 20\% = \$20,000$$

The Sponsor shall pay any amounts described in or calculated pursuant to this Exhibit E within 30 days of receipt of a written statement from the County. If not timely paid by the Sponsor, the amount due is subject to the minimum amount of interest that the law may permit with respect to delinquent *ad valorem* tax payments. The repayment obligation described in this Exhibit E survives termination of this Fee Agreement.

Richland County Council Request for Action

Subject:

Review of Comprehensive Council Rules

Notes:

October 18, 2022 – The Rules and Appointments Committee recommended approval of the Comprehensive Council Rules.



RICHLAND COUNTY COUNCIL RULES

TABLE OF CONTENTS

RULE I – MEETINGS

- 1.0 Authority**
- 1.1 Purpose and Scope**
- 1.2 Procedure**
- 1.3 Open Meeting**
- 1.4 Executive Sessions**
- 1.5 Quorum**
- 1.6 Agenda**
 - a) Compilation**
 - b) Placing on Agenda-Methods**
 - c) Order**
 - d) Additions**

RULE II – CHAIR

- 2.1 Call to Order**
- 2.2 Preservation of Order**
- 2.3 Transgressions of Order**
- 2.4 Censure**
- 2.5 Points of Order – Appeal**
- 2.6 Participation**
- 2.7 Election**
- 2.8 Vice-Chair**
- 2.9 Signatures**

RULE III – MEMBERS AND MEMBERSHIP

- 3.1 Seating**
- 3.2 Attendance**
- 3.3 Call to Order**
- 3.4 Speaking**
- 3.5 Original Papers**

RULE IV – COMMITTEES

- 4.1 Standing Committees**
 - a) Administration and Finance Committee**
 - b) Development and Services Committee**
 - c) Rules and Appointments Committee**
 - d) Economic Development Committee**
- 4.2 Ad Hoc Committees**
- 4.3 Organization**
- 4.4 Jurisdiction**
- 4.5 Agendas**
- 4.6 Meetings**
- 4.7 Legislative Action**
- 4.8 Reports**
- 4.9 Recommitting**
- 4.10 Budget Work Sessions**
- 4.11 Motions Forwarded to a Committee**

RULE V – LEGISLATIVE ACTION

- 5.1 Emergency Ordinances**
- 5.2 Other Ordinances – Required Readings**
- 5.3 Levying Tax-Incurring Debt-Amending Budget**
- 5.4 Public Hearings**
- 5.5 Second Reading**
- 5.6 Third Reading**
- 5.7 Debate**
- 5.8 Motions During Debate**
- 5.9 Substitute Motions**
- 5.10 Amendments**
- 5.11 Withdrawing Motions**
- 5.12 Privileged Motions**
- 5.13 Suspending Motions**
- 5.14 Motion to Recess**
- 5.15 Delays**
- 5.16 Defeated Actions**
- 5.17 Voting**
- 5.18 Voting for Board and Committee Appointments**
- 5.19 Dividing Question**
- 5.20 Reconsideration**
- 5.21 Public Inspection**
- 5.22 Resolutions**
- 5.23 Proclamations**

RULE VI – RULE CHANGES

- 6.1 Suspension/Amendments**

RICHLAND COUNTY COUNCIL RULES

RULE I: MEETINGS

1.0 Authority

These Rules are adopted pursuant to S.C. Code Ann. Section 4-9-110, which provides that, “[t]he council shall determine its own rules and order of business.”

1.1 Purpose and Scope

These rules shall apply to all meetings of county council, including committee meetings, and to all boards and commissions for which the county council appoints a majority of the members and they have no rules in place. Where applicable, the term “county council” means not only the county council, but also any other board or commission in the county governed by these Rules. These Rules were adopted as guidelines to assist county council, and county boards and commissions in conducting orderly and productive meetings. Any deviation from or waiver of these Rules shall not affect or void any action taken by county council, or a county board or commission. Furthermore, such deviation or waiver does not convey any right or cause of action to third parties not otherwise imposed by law.

1.2 Procedure

In all cases not covered by these rules or by law, the Chair or other presiding officer shall be guided by such rules as are set forth in the most recent edition of *Robert’s Rules of Order*.

1.3 Open Meetings

All meetings of county council shall be open to the public except as provided for in Section 30-4-10 et. seq. of the South Carolina Code of Laws, 1976, as amended. All regular and special called meetings of Council will be broadcast live (and recorded), where practical.

Public notice of regularly scheduled meetings, special called meetings, and committee meetings will be given in accordance with S.C. Code Ann. Section 30-4-80 “Notice of meetings of public bodies.

1.4 Executive Sessions.

In accordance with the South Carolina Freedom of Information Act, “[a] public body may hold a meeting closed to the public” for any of the purposes set forth in S.C. Code Ann. Section 30-4-70. The agenda shall state the reason for the Executive Session. Pursuant to 30-4-70(b), before going into executive session Council shall vote in public on the question and when the vote is favorable, the Chair or presiding officer shall announce the specific purpose of the executive session. No action may be taken in executive session except to (a) adjourn or (b) return to public session.

1.5 Dates/Times

- a) Regular Meetings – Regular Meetings of County Council shall be held on the first and third Tuesday of each month at 6:00 p.m., and on other dates and at any other times determined by Council as part of Council’s Annual Meeting Schedule approved prior to each calendar year (i.e., a “Regular Meeting” may be held other than on the first and third Tuesday of each month at 6:00 p.m., so long as such meeting is approved by Council as part of its Annual Meeting Schedule). Further, the Chair for good cause, with the consent of a majority of the Council members present, may schedule a regular meeting at other times. “Good cause” includes, but is not limited to,

consideration of County holidays, in which case Council may decide to adjust its meeting schedule accordingly.

- b) Special Meetings – Special Meetings may be called by the Chair or a majority of the members. No less than five Council members must be physically present to schedule a Special Called Meeting. The members of Council must be informed of the subject(s) to be discussed at a special meeting. While special called meetings, absent contrary authority, may be held for any purpose Council desires, two frequent reasons necessitating a special meeting include: 1) a special called meeting that is essentially the result of the rescheduling of a meeting that had been regularly scheduled but for whatever reason needs to be moved to a different date or time (i.e., a regular meeting held at a special time not originally scheduled); and 2) a special called meeting to take up a specific matter or matters (i.e., a “limited purpose” meeting). A special called meeting that is in essence a regular meeting that has been moved to a time not originally scheduled should follow the agenda order set forth in Rule 1.7(c) of these rules. A special called meeting that is for a “limited purpose” or “limited purposes” need not follow the agenda order set forth in Rule 1.7(c) of these rules, but instead may follow an agenda that is as specific or general as may be necessary for Council to be informed of the purpose(s) of the limited meeting and to carry out the purpose(s) of the limited meeting.

Electronic Participation – *“Council members are expected to regularly attend meetings in person, but electronic participation may be permitted in circumstances with notification being made to the Chair at least 24 hours prior to the meeting start time.*

Electronic participation, including participation via online platforms such as Zoom, WebEx or similar medium, is permitted in circumstances where a Council member may not be present in Council chambers or other Council meeting location due to illness, public health crises or emergencies, quarantine, government-imposed curfew or restriction on movement, traffic or other delays, or other cause that reasonably would be expected to impede or prevent a member of Council from attending a Council meeting in person. Any Council members participating electronically may not participate in any executive session. Council members participating electronically may choose to abstain from a vote on the issue discussed in executive session.

For the purpose of this section “electronic” participation shall mean videoconferencing or teleconferencing which allows all persons participating in the meeting to hear each other at the same time (and, if videoconferencing, to see each other as well).”

- c) Zoning Public Hearing Meetings – Zoning public hearing meetings shall be held on the fourth Tuesday of each month at 7:00 p.m., unless otherwise scheduled by the Chair for good cause, with the consent of a majority of the Council members present. “Good cause” includes, but is not limited to, consideration of County holidays, in which case Council may decide to adjust its meeting schedule accordingly.

1.6 Quorum

A quorum for the transaction of official business of Council shall consist of six (6) members.

A quorum of a committee, subcommittee or advisory committee of Council shall consist of a simple majority of the fixed membership of the committee, subcommittee or advisory committee.

1.7 Agenda

- a) Compilation – The agenda for regular a meeting of Council shall be compiled by the Clerk of Council on the Tuesday proceeding the first and third Tuesday of the month. *Title of proposed agenda items should be delivered to the Clerk's Office no later than 9:00 AM Tuesday one week prior to the scheduled council meeting and/or before the schedule Horizon meeting. Support documentation should be delivered to the Clerk's Office no later than Noon Wednesday one week prior to the council meeting.*
- b) Placing on Agenda (Methods) – Items for Council consideration may be placed on the agenda by any of these methods:
 - 1) Committee action, or
 - 2) Any item defeated, tabled, or not acted on by committee within 90 days of that item having been placed on the committee's agenda may be placed on the Council agenda when the Clerk's Office has received a written request (including electronic mail or messaging) from three members of Council, or
 - 3) Proclamation introduced by one member of Council presented to the Clerk prior to the agenda deadline, or
 - 4) Items authorized by ordinance (e.g. appointment and commissioning of Code Enforcement Officers), or
 - 5) The item consists of a notice given to the governing body concerning the location of a proposed home for 9 or fewer mentally or physically handicapped persons, or
 - 6) In the case of a resolution honoring or recognizing a citizen or organization, the same by unanimous consent may be placed on the agenda and voted on during Council's motion period, or
 - 7) Administrator's Nomination – this method of placing an item on Council's agenda recognizes that as the County's chief executive officer, the Administrator may from time-to-time have a matter that needs to come before Council that requires action, the delay of which might prejudice the County's interest in a discernable way. In such instances, the Administrator may nominate an item for placement on Council's agenda, and Council may decide to include such item at its pleasure during the adoption of its agenda, or the re-adoption of this agenda should re-adoption be necessary. Any item nominated under this rule:
 - a) Must include a representation by the Administrator, orally or in writing, that the item is time sensitive, exigent or of such immediate importance that taking it up later would or could prejudice the County;

- b) In addition to (a) the Administrator shall provide an explanation as to why the item could not be routed to Council through the committee process or any of the other methods of placement on Council's agenda set forth in 1.7(b) 1-6 or, as to 1.7(b)(a), why committee consideration is not necessary;
 - c) Must be consented to by two-thirds of those members of Council present at the meeting.
- c) Order – the agenda for regular meetings of Council (and those special called meetings that are the result of rescheduling a meeting that had been regularly scheduled, as provided for in Rule 1.5(b) of these rules) shall consist of the following categories of business, to be taken up by the Chair in the order listed.
- 1) Roll Call
 - 2) Invocation
 - 3) Pledge of Allegiance
 - 4) Approval of minutes of previous meetings: a simple majority vote of Council is required to approve minutes. If there are corrections or amendments to the minutes, they may be approved as corrected or amended. Motions to reconsider, rescind, or expunge from the record any previous action must be made prior to adoption of the relevant minutes and any such motion will be placed on the Agenda's Motion Period for debate. Only when an item is expunged can it be reconsidered during the Motion Period. The adopted minutes shall note the motion to reconsider, rescind, or expunge.
 - 5) Adoption of agenda: a two-third majority vote, of those present, is required to adopt the agenda.
 - 6) First County Attorney's Report of Executive Session items: The County Attorney shall report only on those Executive Session items in which the County is represented by outside counsel or in which the County has retained the services of a consultant who is charging the County for services by the hour. In such cases, if it would save the County money to dispose of matters involving outside counsel or consultants at or near the beginning of its meeting, Council may take up such matters during this first Report of Executive Session items. No action shall be taken in executive session. The agenda shall state the reason for Executive Session.
 - 7) Citizens' Input:
 - a) **Agenda Items:** Each person who has signed the Agenda Items Input List to speak before Council may do so for up to 2 minutes; provided, however, the entire Agenda Items citizen input time shall not exceed 30 minutes, except by leave of Council. The Clerk shall be responsible for keeping the time for each speaker, and the timer shall not be started until after the speaker has stated his or her name and address. Anyone who wishes to speak but did not sign up to speak, or signed up on the wrong Input List, may be allowed to speak at

Council's discretion. Input must pertain to items on the agenda for which no public hearing is required or scheduled. Individual members of Council shall not be referred to by name, but instead input should be directed to full Council. Any material that a speaker would like to present to Council, including audio and visual presentations, should be provided to the Clerk of Council prior to the meeting. Exceptions may be made with the consent of a simple majority of those Council members present. In the event a citizen who has signed up to speak intends to speak, or does speak, on behalf of any group, association, community, or anyone besides or in addition to himself or herself, the speaker must provide the Clerk of Council written authorization from such group, association, community, or citizen, prior to the meeting. The Clerk will have available Council members' contact information as listed on the County's website. The Chair may advise speakers to coordinate with or contact County staff as may be appropriate to the issue(s) raised by the speaker. Rule 2.2, Preservation of Order, applies during Citizens' Input. In addition, if it becomes clear that the item addressed or the speaker's input bear no reasonable relationship to any matter over which Richland County has responsibility, the Chair may discontinue that input prior to the running of the time limit for speakers set forth herein.

- b) **Non-Agenda Items Input:** Anyone who wishes to speak on an item not on the agenda or bring a concern to Council's attention may speak for no more than two minutes; provided, however, the entire Non-Agenda Items citizen input time shall not last longer than 30 minutes, except by leave of Council. The Clerk shall be responsible for keeping the time for each speaker, and the timer shall not be started until after the speaker has stated his or her name and address. Anyone who wishes to speak but did not sign up to speak, or signed up to speak on the wrong Input List, may be allowed to speak at Council's discretion. Individual members Council shall not be referred to by name, but instead input should be directed to the full Council. Any material that a speaker would like to present to Council, including audio and visual presentations, should be provided to the Clerk of Council prior to the meeting. Exceptions may be made with the consent of a simple majority of those Council members present. In the event a speaker who has signed up to speak, or does speak, on behalf of any group, association, community, or anyone besides, or in addition to, himself or herself, must provide to the Clerk of Council written authorization from such group, association, community, or citizen, prior to the meeting. The Clerk will have available Council members' contact information as listed on the County's website. The Chair may advise speakers to coordinate with or contact County staff as may be appropriate to the issue(s) raised by the speaker. Rule 2.2, Preservation of Order, applies during Citizens' Input.
- 8) Report of the County Administrator: The County Administrator shall make recommendations or announcements concerning county affairs. Items for action shall be taken under this section only upon compliance with Rule 1.7(b)(7).
- 9) Report of the Clerk of Council: The Clerk of Council shall make announcements, if any, concerning county affairs.

- 10) Report of the Chair: The Chair of Council shall make announcements, if any, concerning county affairs.
- 11) Presentations: The party requesting to make the presentation shall set forth a written request that includes (1) the name of the person, group, association, or entity making the presentation, (2) the name and contact information for the presenter(s) or spokesperson(s) thereof, and (3) the purpose and nature of the presentation. The request should be succinct but have enough information to meaningfully inform Council and the public of the substance of the presentation, and be submitted to the Clerk of Council in advance of the agenda deadline for the meeting where the presentation is intended to be made. The presentation request shall be included in the agenda packet. Presentations shall be limited to five (5) minutes and shall be heard on the third Tuesday of the month, except by leave of Council. All presentations shall be approved by the Chair before placement on any Council agenda. No presentation shall be heard which is not on the Council agenda prior to the start of the meeting. No more than three presentations will be allowed at each meeting. The purpose of this rule is so that Council may plan its meetings accordingly, given the variety of presentations and lengths thereof, and to assess the merits of a given presentation. Presentations shall not be used to request funding or resources support from the County.
- 12) Public Hearings: Each person who has signed up may speak to Council for up to two (2) minutes concerning an item for which there is a public hearing; provided, however, the entire public hearing time for any one item shall not exceed 30 minutes, except by leave of Council.

Any material that a speaker intends to present to Council, including audio and visual presentations, must be submitted to the Clerk of Council prior to the meeting. Exceptions may be made with the consent of a simple majority of those Council members present. The Chair will request that in the event someone who has signed up to speak intends to speak, or does speak, on behalf of any group, association, community, or anyone besides, or in addition, to himself or herself, that the speaker advise Council during his or her public hearing input of that fact, and name or identify anyone else for whom the citizen is speaking or represents. The Clerk shall be responsible for keeping the time for each speaker, and the timer shall not be started until after the speaker has stated his or her name and address.

Anyone who wishes to speak but did not sign up to speak, or signed up to speak on the wrong public hearing list, may be allowed to speak at Council's discretion. Individual members of Council shall not be referred to by name, but instead input should be directed to the full Council. Rule 2.2, Preservation of Order, applies during Public Hearings. In addition, if it becomes clear that the speaker's input bears no reasonable relationship to the item subject to the Public Hearing, the Chair may discontinue that input prior to the running of the time limit for speakers set forth herein.

- 13) Consent items: Items shall consist of those matters that do not require further discussion by Council that have been forwarded to Council by the unanimous vote of the Committee; provided, however, that an item forwarded to Council by Committee without recommendation shall not be listed as a Consent Agenda item. Any member

of Council can remove an item from the Consent Agenda prior to adoption of the agenda. The Chair has the discretion to place items on the Consent Agenda, if in the judgment of the Chair; those items are unlikely to be debated.

14) Third reading: final approval of Ordinances.

15) Second reading.

16) Requests by Council members: items may include those that were defeated (or deferred beyond 90 days) by committee and reintroduced by written request of three members of Council.

17) Other Items.

18) Second County Attorney's Report of Executive Session items: The County Attorney shall report on the remaining Executive Session items. No action shall be taken in executive session. The agenda shall state the reason for Executive Session.

19) Motion period/Announcements: Any Council member may make an announcement or introduce an item (excluding resolutions) for referral to a Committee; however, any Council member wishing to make a motion during the "motion period" must have transmitted a written request to the Clerk's Office by the deadline for posting the agenda for a regularly scheduled meeting of Council in accordance with the South Carolina Freedom of Information Act (i.e. twenty-four hours prior to such meeting) so that the nature of the motion appears on the agenda. Motions for resolutions and ordinances may be forwarded to a Committee for further deliberation or, by unanimous consent, the resolution shall be deemed adopted or the ordinance may be given first reading. Further, any Council member may use this time to inform Council, Administration, and County staff of upcoming matters or items likely to come before Council, to orient Administration and staff thereto, and to request information or the commencement of research in the ordinary course of Council-Administrator dealings.

When referring an item to committee, a Council Member must specify the intent of his or her motion.

If a Council Member does not specify the intent of his or her motion, the Chair shall ask the maker of the motion for clarification. Immediately following each motion, the Chair shall determine the committee to which the item will be referred, according to the guidelines established in Rule 4.1.

20) Pending items: Issues that have been raised by a Council member wherein a response is expected from staff shall be listed on the agenda along with a time frame in which a response from staff will be provided. These items shall be for information only and no discussion shall take place.

21) Adjourn.

d) Additions – Pursuant to S.C. Code Ann. Section 30-4-80, "Once an agenda for a regular, called, special, or rescheduled meeting is posted pursuant to this subsection, no items

may be added to the agenda without an additional twenty-four hours' notice to the public, which must be made in the same manner as the original posting. After the meeting begins, an item upon which action can be taken only may be added to the agenda by a two-thirds vote of the members present and voting; however, if the item is one upon which final action can be taken at the meeting or if the item is one in which there has not been and will not be an opportunity for public comment with prior public notice given in accordance with this section, it only may be added to the agenda by a two-thirds vote of the members present and voting and upon a finding by the body that an emergency or an exigent circumstance exists if the item is not added to the agenda. Nothing herein relieves a public body of any notice requirement with regard to any statutorily required public hearing."

RULES II: THE CHAIR

2.1 Call to Order

The Chair shall call Council meetings to order at their posted time or as soon thereafter as practical on the first and third Tuesday of each month and, if a quorum is present, proceed to the meeting agenda. The Vice Chair shall preside in the absence of the Chair. In the absence of the Chair and Vice Chair, the most senior member in attendance shall preside.

2.2 Preservation of Order

The Chair shall preserve order and decorum and, in case of disturbance or disorderly conduct in the Chamber or the lobby, may cause the same to be cleared. The members of Council agree to, and all of those attending Council's meetings are expected to, adhere to the following "Code of Conduct":

"I pledge that I may disagree, but will be respectful of all. I will direct all comments to the issues. I will refrain from personal attacks."

2.3 Transgression of Order

If any member, in speaking or otherwise, transgresses the Rules of Richland County Council, the Chair shall call such member to order. If repeated cries of order are ineffective, the Chair may call a member by name, and if the Chair deems it necessary, shall state the offense committed. The member may be heard in response.

2.4 — Censure

~~Recognizing the value and contributions of each member of Council, and that each member is elected by the people of a defined district and accountable to the people thereof, subject to removal only by the governor as provided for by State law, while at the same time realizing that the functioning of Council depends on the professional and civility of each member, in rare circumstances where a member's conduct so thoroughly transgresses Council's Code of Conduct described in Rule 2.2, Council may censure a member.~~

~~Prior to censuring one of its members, Council must pass a motion to commence censure proceedings. A motion to commence censure proceedings, having been made and properly seconded, requires a two-thirds vote of the full Council (i.e. at least 8 members, whether a full Council has been seated or not, must vote to censure a member).~~

~~—————If a motion to commence censure proceedings passes, Council shall hold a hearing on censure of the member named in the motion. The hearing shall be held at the next regular or special called meeting of Council, provided that a period of at least ten (10) days has elapsed from the date the motion to commence censure proceedings was adopted to the censure proceedings itself. In no event shall the hearing be held at the same meeting, or on the same day, as the adoption of the motion to commence censure proceedings.~~

~~—————At the hearing the Chair shall state the basis for censure, or may call upon any member who voted to commence censure proceedings to state the basis for censure if the basis is unknown to the Chair. Any member may then speak during the censure proceeding for up to five (5) minutes. No member may speak more than once during the censure proceeding absent leave of the Chair. The member subject to the censure proceeding shall have up to fifteen (15) minutes to speak in reply, but additional rebuttal time may be granted by the Chair.~~

~~At the conclusion of Council input as provided for herein, any member who believes censure is in order may make a motion to censure the member. If that motion does not receive a second, or, if seconded, it does not pass by a two-thirds vote of the full Council (i.e. at least 8 members, whether a full Council has been seated or not), the matter is concluded and it shall be noted in the record that no impropriety has been found on the part of the member and that censure is not proper. If a motion to censure is made and properly seconded, and receives at least eight (8) votes, the member shall be censured and the records of County Council shall so reflect. Once a member is censured on a matter, no other action is in order with respect to the same matter.~~

2.5 Points of Order – Appeal

- a) Point of Order [Motion to Raise a Question of Order] - The Point of Order takes precedence over any question from which it arose. It yields to any privileged motion and a motion to lay the underlying question on the table. The Point of Order is not debatable (except that the Chair may ask the member raising the point to explain it), it is not amendable, and cannot be reconsidered. It does not require a second. The Point of Order is in order when another person has the floor and can interrupt a person speaking if the point requires attention at the time it is raised. The Chair shall decide all points of order, subject to an appeal by any member.
- b) Appeal – The duties of the Chair include making rulings on questions of parliamentary procedure. An Appeal is the vehicle available to members of council who believe that the Chair’s ruling was erroneous. The Appeal is in order when another has the floor, but must be taken immediately after the ruling and is out of order if other business has intervened. It is debatable unless the underlying question is not debatable or if the Appeal relates to decorum or priority of business; it is not amendable.

The decision of the Chair stands unless reversed by a majority of the members; the Chair may vote to create a tie and thus sustain the ruling. An Appeal takes precedence over any pending questions at the time the Chair makes the ruling.

If debatable, each member may speak only once and for no longer than ten (10) minutes each, except by permission of the Council. An Appeal can be reconsidered.

2.6 Participation

The Chair shall vote in all cases (except when the Chair may be personally or pecuniarily interested) in accordance with Rule 5.18. The Chair may enter into the debate of the Council, but should not use the office of the Chair to wield influence over the other members.

2.7 Election

The Chair shall be elected at the first regular or special called meeting of the Council in January, or as soon thereafter as may be practical, by the membership of the Council. The Chair shall serve continuously until the following January unless removed by a two-thirds majority vote of the full Council.

2.8 Vice Chair

The Vice Chair shall be elected at the first regular or special called Council meeting in January or as soon thereafter as may be practical, by the membership of the Council. The Vice Chair shall serve continuously until the following January unless removed by a two-thirds majority vote of the full Council.

2.9 Signatures

The Chair shall sign all ordinances, resolutions and other documents approved or authorized by the Council. In the absence of the Chair, the Vice Chair is authorized to sign official documents of the County.

The Clerk of Council and the Deputy Clerk of Council are authorized to sign or attest to official documents of the County.

RULE III: MEMBERS AND MEMBERSHIP

3.1 Seating

At the first regular or special called meeting in January, after the election and seating of the Chair and Vice Chair of Council, as provided for in Rules 2.7 and 2.8, respectively, Council members shall select their seats based first on seniority in years of continuous service and then in alphabetical order.

3.2 Attendance

Subject to the rule for electronic participation set forth herein, each member is expected to be within the Council Chambers during Council's meetings, or within the meeting room of any alternate location of a Council meeting. The Chair must note for the record any member's absence and the circumstances therefor as appropriate, and such absence and the circumstances therefor, if known, shall be noted in the minutes.

3.3 Call to Order

When the Council is called to order, each member shall take his/her place on the dais and shall act with decorum.

3.4 Speaking

The Chair shall hear the members desiring to speak in the order in which they express interest in speaking, recognizing each member in turn. Members shall respectfully address the Chair and shall avoid disrespect to the Council, and shall confine all remarks to the question under consideration. No member shall speak more than twice on the same question without leave of Council, except merely to provide clarification. Each member shall be allowed to speak no more than five (5) minutes for debate on any one issue before Council. If a member has the floor and is

addressing the body, that member shall not lose the floor by asking a question of any member of the body. If a member shall be called to order while speaking, such member shall forfeit the floor until the question of order is decided.

3.5 Original Papers

Any member leaving a meeting of Council or its committees who possesses original papers relating to the business of the Council (signed ordinances, contracts, etc.), shall leave original papers with the Clerk before departing.

RULE IV: COMMITTEES

4.1 Standing Committees

The Chair of County Council shall appoint members of the following standing committees by the first regular meeting in February each year or as soon thereafter as practical:

- a) **Administration and Finance Committee**, consisting of five (5) members, functions as a committee of ways and means to which matters dealing with general-administration, the budget, capital improvements, taxation, and bond issues should be referred. Customarily meets on the 4th Tuesday of the month.
- b) **Development and Services Committee**, consisting of five (5) members, functions in the area(s) of general operational matters, and those matters relating to the function and activities of the County Department of Public Works and Engineering. Customarily meets on the 4th Tuesday of the month.
- c) **Rules and Appointments Committee**, consisting of three (3) members, functions as a review and advisory body on the rules of County Council and serves as an interviewing and recommending body for applicants to County boards, commissions, and committees created by and whose members consists in whole or in part in County Council appointments. The Committee meets on an as needed basis.

The vacancy on a County board, commission, or committee shall be announced at least two meetings prior Council making the appointment. Such vacancy will be advertised in a local newspaper, the County website, PIO's Weekly Review and other appropriate media. Any individual who wishes to apply for service on a County board, commission, or committee must submit an application to the Clerk of Council. The Clerk of Council shall supply the application form. The Clerk shall, on the date designated by the Rules and Appointments Committee, submit all applications to the County Council for consideration. The County Council shall then elect an individual to fill the vacancy or vacancies, which exist at that time in accordance with the voting procedures set forth in Rule 5.19. After an appointment(s) has been made, applications shall be retained by the Clerk of Council for one (1) year and may be considered upon the request of the applicant whenever a vacancy occurs within that one (1) year period of time.

- d) **Economic Development Committee**, consisting of three (3) members, serves to consider economic development matters brought before them and make recommendations to the full Council. The Committee meets on an as needed basis.

Absent exigent circumstances, no meeting of a standing committee of council shall be scheduled at the same time as another meeting of a standing committee of council.

4.2 Ad Hoc Committees

Ad Hoc Committees will be appointed by the Chair on an as needed basis and shall follow the same rules and procedures as the Standing Committees.

4.3 Organization

Each committee of Council shall select a Chair and function as an advisory committee to full Council. Once appointed for a year, no member of a committee may be removed by the Chair of Council without the approval of Council. During the remainder of the year, any vacancy, occurring on these committees shall be filled by the Chair, as soon as it may reasonably be accomplished. Any member of Council may attend any meeting of the committee, provided, however, only members of the particular committee may vote on matters before that committee.

The Chair of County Council shall be an ex-officio member of the Rules and Appointments Committee and Economic Development Committee.

4.4 Jurisdiction

Unless otherwise ordered, committees shall have jurisdiction only over matters pertaining to the subjects indicated by the names of the respective committees. Personnel matters shall be discussed by the full Council and not by standing or special committees, except in the case of ad hoc search or other committees specifically appointed to assist in matters related to any County official the Council hires directly.

4.5 Agendas

Appropriate written backup material for all items of business that are to be included in the Administration and Finance or Development and Services Committee agendas must be delivered electronically to the County Administrator's Office no later than 5:00 p.m. on the date two (2) weeks prior to the committee's scheduled meeting date.

In exceptional circumstances, time-sensitive items received after the deadline may be added to a committee's agenda at the discretion of the committee's Chairperson, provided the addition is made before agendas are printed and distributed. In the event that the Chair of the committee cannot be reached before agendas are printed, then such items may be added with the consent of a majority of the committee's members. If a majority of the committee's members cannot be reached, the Chair of County Council shall have the discretion to add such items. Once the committee agendas have been printed and distributed publicly, changes to the agenda may only be made by the unanimous consent of the committee during the committee meeting.

Agendas with backup information shall be provided to all members of Council on or before the Thursday prior to the committee meeting.

4.6 Meetings

Committees shall meet regularly in a location designated by the Committee Chair; provided, however, that Ad Hoc Committees shall meet on an as needed basis only at the call of such Committee's Chair. No committee shall meet while the Council is meeting without special leave. No committee shall sit unless a quorum is present. No Council member shall be allowed under any circumstances to vote by proxy. Members of Council, whenever possible, shall make inquiries and requests for information at the Committee meetings. At the request of a member of the committee, members of the public may address a Committee with the permission of the Committee Chair and with the consent of the Committee; however, any material that a citizen intends to present, including audio and visual presentations, must be provided to the Clerk of Council prior to the Committee meeting, except by leave of the Committee.

4.7 Legislative Action

Items referred to a committee for consideration shall be listed under one of the following categories: "Items for Action" or "Items for Information, Discussion, or Preliminary Action". Additional agenda categories (including, but not limited to, "Presentations," "Notifications", and "Items Pending Analysis") may be added to the agenda as needed for items not requiring immediate committee action.

- a) Items for Action – For all items requiring action, the committee shall take one of the following actions by majority vote:
 - 1) Recommend that Council approve the item, which may or may not include amendments or modifications to the original request;
 - 2) Recommend that Council deny the item;
 - 3) Forward the item to Council without a recommendation;
 - 4) Defer consideration of the item to a future committee meeting;
 - 5) Refer the item to another committee or commission; or
 - 6) Table the item.

- b) Items for Information, Discussion or Preliminary Action – The committee shall take one of the following actions by majority vote:
 - 1) Direct the Administrator to bring the item back for action at a specified committee meeting;
 - 2) Defer consideration of the item until a specified committee meeting; or
 - 3) Receive the item for information or discussion purposes only, and dispose of the item from the committee agenda. Items so removed will be reported as such by the committee to Council;
 - 4) Notwithstanding items 1 through 3 in this subsection, any item on the Administration and Finance (A&F) or the Development and Services (D&S) Committee agendas listed as an "Item Pending Analysis" must be resolved, tabled or otherwise disposed of within 100 days of that matter's referral to the A&F or D&S Committee.

4.7 Reports

All committee recommendations requiring formal action by Council shall be included in the agenda and distributed to all members of Council prior to consideration and adoption by Council, provided that if any matter is considered by the majority of any committee to be time sensitive or an emergency, copies of such reports may be furnished to each member of Council at the time of said Council meeting.

All items presented to Council by a committee must carry the committee's disposition of the item, whether that disposition is a recommendation for approval, a recommendation for denial, no recommendation or to make any other disposition with respect to the item.

Any item not reported out to the full council by committee within 90 days of that item having first appeared on the committee's agenda may be placed on the Council agenda when the Clerk's Office has received a written report (includes electronic mail or messaging) from three (3) members of Council, not less than 24 hours prior to the scheduled meeting.

4.8 Recommitting

Any item coming before Council may be referred to a committee or recommitted to a committee of Council before a final decision by the full Council thereon.

4.9 Budget Work Session

The Council shall meet as a Committee of the Whole for budget work sessions prior to first reading of the budget.

4.10 Motions Forwarded to a Committee

Any motion forwarded to a committee by the Chair, or in the Chair's absence, the Vice Chair, or in the Vice Chair's absence, the acting Chair, will appear on that committee's agenda. Any item forwarded to a committee that is not completed will be listed at the end of the committee's subsequent agenda(s) under, "Items Pending Analysis" and the reason the item remains pending.

RULE V: LEGISLATIVE ACTION

5.1 Emergency Ordinances

To meet public emergencies affecting life, health, safety or the property of the people, emergency ordinances may be adopted upon a two-thirds affirmative vote of the Council members present. Such an ordinance is effective immediately upon its enactment without regard to any public hearing, reading, publication, or notice requirements. It automatically expires after 60 days. Every emergency ordinance shall be designated as such and shall contain a declaration that an emergency exists and describe the emergency.

Emergency ordinances shall not levy taxes, grant, renew, or extend a franchise, or impose or change a service rate.

5.2 Other Ordinances – Required Readings

With the exception of emergency ordinances, all ordinances, including those making supplemental appropriations, shall receive approval at three public meetings of Council on three separate days with an interval of not less than seven (7) days between the second and third readings. An ordinance shall be deemed passed upon third reading approval and thereafter can be rescinded only by a motion to reconsider or rescind that is made prior to approval of the minutes.

Any ordinance that does not receive three reading approval by Council may not be reintroduced for twelve (12) months from the date the minutes reflecting its denial (i.e., the final time the ordinance was read and did not pass) were approved, absent consent of two-thirds of the full Council.

5.3 Levying Tax/Incurring Debt/Amending Budget

Ordinances levying a tax or incurring indebtedness shall not be passed unless voted for on each reading by at least six (6) members of Council assembled and with appropriate back up material provided for each reading.

5.4 Public Hearings

Public hearings shall be held before final action is taken to:

- a) Adopt annual operational and capital budgets;
- b) Make appropriations, including supplemental appropriations;
- c) Adopt building, housing, electrical, plumbing, gas and all other regulatory codes;
- d) Adopt zoning and subdivision regulations;

- e) Levy taxes;
- f) Sell, lease or contract to sell or lease real property owned by the county;
- g) Impose ad valorem property taxes upon a fire service area; or
- h) Provide for the distribution of assets following the abolishment of a special purpose district.

Final action for any of the first six (6) matters must be in the form of an ordinance. A minimum of fifteen (15) days' notice of the time and place of the hearing must be published in at least one newspaper of general circulation in the county, prior to conducting a public hearing for any of the above categories of ordinances.

Notice for item (g) must be provided once a week for three (3) successive weeks in a newspaper of general circulation in the county, and the hearing must occur fewer than sixteen (16) days following the first notice. Item (h) requires at least two (2) public hearings with ten (10) days prior notice published in a newspaper of general circulation prior to each meeting.

5.5 Second Reading

Upon second reading of an ordinance, the ordinance shall be placed on Council's agenda for third reading at its next meeting or at other time as scheduled by Council; provided; however, there must be an interval of not less than seven (7) days between second and third readings.

Each ordinance affecting the expenditure of money by the County shall receive the affirmative vote of Council on each reading, noting that the County Administrator's comment shall inform Council regarding its effect on the finances of the County, unless this requirement is waived by Council or the financial effect is evident on the face of the ordinance.

5.6 Third Reading

Full debate and amendments shall be allowed on third reading.

5.7 Debate

Debate among members of Council is in order only after a motion has been stated by the Chair and has been seconded. Any motion shall, if desired by the Chair or any other member, be reduced to writing and delivered to the Chair and read before it shall be debated.

5.8 Motions During Debate

When a motion has been stated and seconded and debate has begun, the following motions shall be in order:

- a) To approve (the matter under consideration);
- b) To deny;
- c) To amend;
- d) To substitute one more (related to the matter) for another;
- e) To adjourn;
- f) To recess;
- g) To continue or postpone the matter to a date certain;
- h) To continue or postpone the matter indefinitely;
- i) To return to the agenda if the item under consideration has been taken out of turn;
- j) To table the matter;
- k) To call for the question ("close debate" or move "for the previous question");
- l) To raise a question of privilege;
- m) To convene an executive session;

- n) To refer the matter to a committee (or “to commit”);
- o) To recommit a matter (send back to committee);
- p) To divide the question;
- q) To strike some or all of the matter (similar to substitute motion or amendment); and
- r) To seek information of “clarification” on an aspect of the matter under debate.

5.9 Substitute Motion

No more than two (2) motions may be received in substitute for the motion on the floor. Any substitute motion defeated by vote of Council shall be counted as one of two (2) permissible substitute motions, but any substitute motion, which fails for lack of a second, shall not be so counted.

5.10 Amendments

A proposed amendment shall be in order regardless of the number of changes proposed therein to the matter under debate, provided such amendment is otherwise in order, and shall be considered in the order in which it is received.

5.11 Withdrawing Motions

The member who introduced a motion may withdraw it before a decision on it or on any amendment to it, so long as the member seconding the motion shall not object; provided, however, that no motion may be withdrawn after the previous question has been called.

5.12 Privileged Motions

Motions to adjourn, to recess, to raise a question of privilege, to convene an executive session, or to return to the agenda if an item is taken out of turn shall always be in order except while the Council is actually engaged in deciding a question. A motion to adjourn or to take a recess, having been defeated, no new motion to adjourn or take a recess shall be in order until fifteen (15) minutes shall elapse from the decision of the former motion even though such motion to recess might be to recess to a different time.

5.13 Suspending Motions

The following instances may suspend any matter before Council, temporarily:

- 1) Point of order;
- 2) Point of personal privilege;
- 3) Point of information;
- 4) Question of recess; and
- 5) Other incidental questions, such as of reading papers, dividing a question, withdrawing a motion, or excusing a member from voting.

5.14 Motion to Recess

A motion to recess may state the time for reconvening. In the absence of such stated time, reconvening shall be at the call of the Chair.

5.15 Delays

The Chair shall entertain no motion that would have the effect of unnecessarily to delaying the business of Council.

5.16 Defeated Actions

Once an action of any kind has been proposed and defeated twice during two (2) separate regular or called meetings of Council, within a period of sixty (60) days, no motion of the same

effect may be allowed with regard to the same question for a period of one (1) year from the date of initial motion, without the consent of a majority plus one (1) of the entire Council. The names of the consenting Council members shall be presented to the Chair prior the listing of the item on the agenda.

5.17 Voting

Each member shall vote on each question put forth, except that no member shall be permitted to vote on any question in which that member has a direct personal or pecuniary interest, or in which that member perceives that he or she has a direct personal or pecuniary interest, or in which his or her participation might create an appearance of impropriety in that member's estimation.

If a member does not cast a vote on the question put, such member will not be considered to have voted with either the prevailing or the non-prevailing side.

In the case of a tie vote, the prevailing side is the side that voted against approval of the matter voted upon (e.g. if the matter before Council is a vote to continue an item until the next meeting, and the vote on that question is 5-5, the motion did not pass, the item is not continued and the side prevailing as to the motion is the side that voted not to have continued the item).

If voting an abstention, a reason for the abstention must be stated at the time of the abstention, or delivered to the Clerk following the meeting, and recorded in the minutes. No member shall, under any circumstances be permitted to vote after a decision has been announced by the Chair. Following the vote, an absent member may be permitted to declare the vote she/he would have given if present, but such vote shall not affect the previous question.

Voting shall be by electronic means (i.e. via the electronic voting system) unless conditions at the time of a given vote do not permit use of the electronic voting system (e.g. it is inoperable, not working properly, there is a power failure, Council is hold its meeting in a location that does not have or accommodate electronic voting, or other condition prohibiting electronic voting). In such a case, voting by a show of hands shall be in order.

Votes shall be recorded in the minutes.

5.18 Voting for Board and Committee Appointments

Voting to Elect Boards, Committees, and Commissions. When council is voting to elect one or more persons to open positions on a board, committee, or commission, ballot elections should be used if the number of candidates exceeds the number of positions available. With a ballot election, each council member shall vote—on one ballot—for up to as many positions as are open. Each member shall sign or otherwise mark his or her ballot and the minutes will reflect each member's vote. Members may vote by ballot for someone who was not nominated. Each ballot is considered one vote cast, and a candidate must receive a majority of votes to be elected. If no candidate receives a majority vote, balloting continues as needed until all positions are filled. If fewer than the proper number of candidates receive a majority vote, those candidates receiving a majority are elected, and balloting continues with all other candidates remaining on the ballot. If more candidates receive a majority vote than there are positions open, those receiving the largest number of votes will be elected and those receiving a majority, but tied for last of those receiving a majority, will remain on the ballot for repeat balloting, as needed. If all positions are not filled after the first vote, no candidates shall be involuntarily eliminated.

5.19 Dividing the Question

Any member may call for the division of a question. Council may then divide the question if it can be so comprehended that, one part being taken away, the rest can stand for decision. A motion to divide the question shall require a second and shall be effective upon the vote of a majority of members present and voting.

5.20 Reconsideration

After a question has been decided, any member who voted with the prevailing side may move for a reconsideration, and any member may second such a motion. However, if Council either shall refuse to reconsider or shall affirm its first decision, then no further reconsideration shall be in order, except by unanimous consent. The motion to reconsider shall have precedence over all other main motions, but it may be introduced only on the day of the decision in question or during the next succeeding session of Council prior to the approval of the minutes. Any subsequent proposal to alter the decision of Council must take the form of a main motion to rescind.

5.21 Public Inspection

After adoption, the full ordinance shall be made available for public inspection through the Office of the Clerk of Council.

5.22 Resolutions

Council may adopt Resolutions to formally express its opinions or desires. Upon adoption, the Chairperson shall execute the document on behalf of the entire Council.

5.23 Proclamations

An individual council member may issue a Proclamation as an expression of his or her personal opinion or desire. The Proclamation shall be signed by the initiating council member and shall not require action by the Council.

RULE VI: RULE CHANGES

6.1 Suspension/Amendments

These rules may be suspended by unanimous consent.

Absent unanimous consent, these rules may be suspended 1) with concurrence of two-thirds of the members of the whole (e.g. eight (8) out of eleven (11) members) and 2) after twenty-four (24) hours' notice of suspension of the rule or rules in question has been given in accordance with the South Carolina Freedom of Information Act.

These rules may be amended at the discretion of the County Council upon approval by two-thirds of the members of the whole (e.g. eight (8) out of the eleven (11) members) after twenty-four (24) hours' notice of the proposed amendment of the rule or rules in question has been given in accordance with the South Carolina Freedom of Information Act.

{My comments and suggested language are in italics.}

1.1 Purpose and Scope

These Rules shall apply to all meetings of county council, including committee meetings to assist county council in conducting orderly meetings following parliamentary procedure.

These Rules shall apply to all meetings of county council, including committee meetings, and to all boards and commissions for which the county council appoints a majority of the members. Where applicable, the term "county council" means not only the county council, but also any other board or commission in the county governed by these Rules. These Rules were adopted as guidelines to assist county council, and county boards and commissions in conducting orderly and productive meetings. Any deviation from or waiver of these Rules shall not affect or void any action taken by county council, or a county board or commission. Furthermore, such deviation or waiver does not convey any right or cause of action to third parties not otherwise imposed by law.

1.3 Open Meetings

All meetings of Council, which include committee, subcommittee, and advisory committee meetings, shall be open to the public except as provided for in Section 30-4-10 et. seq. of the South Carolina Code of Laws, 1976, as amended. All regular and special called meetings of Council will be broadcast live (and recorded) on the County's website, unless circumstances make it impractical or impossible to broadcast or record such meeting. This could include technical issues, no access at a given meeting location (e.g., if a meeting is held someplace other than Council's normal meeting place, excessive costs) or other difficulty. For the purpose of this Rule only, excessive costs shall mean costs beyond the normal cost for providing the broadcast.

Public notice of regularly scheduled meetings, special called meetings, and committee meetings will be given in accordance with S.C. Code Ann. Section 30-4-80 "Notice of meetings of public bodies."

SUGGESTED LANGUAGE: *All meetings of county council shall be open to the public except as provided for in Section 30-4-10 et. seq. of the South Carolina Code of Laws, 1976, as amended. All regular and special called meetings of Council will be broadcast live (and recorded), where practical.*

Public notice of regularly scheduled meetings, special called meetings, and committee meetings will be given in accordance with S.C. Code Ann. Section 30-4-80 "Notice of meetings of public bodies."

SUGGESTED NEW RULE TO ADD: *Model Rule 3.1. Role of the Individual Council Member. County council is a policy-making, legislative body. It provides a vision for the county and provides guidelines to county*

administration regarding how the county is to be run. County council members have authority only when acting together, speaking with one voice, and have no individual authority over county operations.

1.5 Dates/Times

- a) Regular Meetings – Regular Meetings of County Council shall be held on the first and third Tuesday of each month at 6:00 p.m., and on other dates and at any other times determined by Council as part of Council’s Annual Meeting Schedule approved prior to each calendar year (i.e., a “Regular Meeting” may be held other than on the first and third Tuesday of each month at 6:00 p.m., so long as such meeting is approved by Council as part of its Annual Meeting Schedule). Further, the Chair for good cause, with the consent of a majority of the Council members present, may schedule a regular meeting at other times. “Good cause” includes, but is not limited to, consideration of County holidays, in which case Council may decide to adjust its meeting schedule accordingly.
- b) Special Meetings – Special Meetings may be called by the Chair or a majority of the members. No less than five Council members must be physically present to schedule a Special Called Meeting. The members of Council must be informed of the subject(s) to be discussed at a special meeting. While special called meetings, absent contrary authority, may be held for any purpose Council desires, two frequent reasons necessitating a special meeting include: 1) a special called meeting that is essentially the result of the rescheduling of a meeting that had been regularly scheduled but for whatever reason needs to be moved to a different date or time (i.e., a regular meeting held at a special time not originally scheduled); and 2) a special called meeting to take up a specific matter or matters (i.e., a “limited purpose” meeting). A special called meeting that is in essence a regular meeting that has been moved to a time not originally scheduled should follow the agenda order set forth in Rule 1.7(c) of these rules. A special called meeting that is for a “limited purpose” or “limited purposes” need not follow the agenda order set forth in Rule 1.7(c) of these rules, but instead may follow an agenda that is as specific or general as may be necessary for Council to be informed of the purpose(s) of the limited meeting and to carry out the purpose(s) of the limited meeting.

Electronic Participation – During any Special Called meeting, not held in conjunction with a regularly schedule Zoning Public Hearing, any Council member may participate in the meeting via electronic participation; provided, however, that a member participating electronically may not participate in any executive session. Council members participating electronically may choose to abstain from a vote on the issue discussed in executive session.

For the purposes of this section, “electronic” participation shall mean videoconferencing or teleconferencing which allows all persons participating in the meeting to hear each other at the same time (and, if videoconferencing, to see each other as well). Electronic participation shall only be allowed in a Special Called meeting of Council.

SAMPLE LANGUAGE (SIMPLER):

Special meetings may be called by the chair or by the majority of county council, provided that the notice requirements are met. Meetings, whether scheduled, rescheduled, or called, may be canceled or rescheduled by the chair or by a majority of county council, provided that the requirement for at least one meeting per month is met. Meeting notice requirements apply to committee meetings as well as meetings of the full council.

1.7 Agenda

COMMENTS: *The strict rules for time leave almost no room for dealing with real issues that may arise in the days following the deadlines. Sometimes maneuverability is best.*

19) Motion period/Announcements:

COMMENTS: *This rule appears to contradict other time rules that require materials and items an entire week before the meeting. Does this 24 hour motion rule still apply?*

2.4 Censure

COMMENT: *Recommend removal. This rule would likely never be used as there are other methods for dealing with errant member behavior. This rule, however, moves into a quasi-judicial proceeding with no real endgame.*

2.5 Points of Order – Appeal

COMMENT: *Recommend removal as it doesn't change Robert's Rules. I would recommend a motion cheat sheet and a general parliamentary procedure training. If you'd prefer to add some of these rules back, I suggest the Model Rules version, or a version thereof.*

4.1 Standing Committees

The Chair of County Council shall appoint members of the following standing committees by the first regular meeting in February each year or as soon thereafter as practical:

- a) **Administration and Finance Committee**, consisting of five (5) members, functions as a committee of ways and means to which matters dealing with general-administration, the budget, capital improvements, taxation, and bond issues should be referred. Customarily meets on the 4th Tuesday of the month.
- b) **Development and Services Committee**, consisting of five (5) members, functions in the area(s) of general operational matters, and those matters relating to the function and activities of the County Department of Public Works and Engineering. Customarily meets on the 4th Tuesday of the month.
- c) **Rules and Appointments Committee**, consisting of three (3) members, functions as a review and advisory body on the rules of County Council and serves as an interviewing and recommending body for applicants to County boards, commissions, and committees

created by and whose members consists in whole or in part in County Council appointments. The Committee meets on an as needed basis.

~~The vacancy on a County board, commission, or committee shall be announced at least two meetings prior Council making the appointment. Such vacancy will be advertised in a local newspaper, the County website, PIO's Weekly Review and other appropriate media. Any individual who wishes to apply for service on a County board, commission, or committee must submit an application to the Clerk of Council. The Clerk of Council shall supply the application form. The Clerk shall, on the date designated by the Rules and Appointments Committee, submit all applications to the County Council for consideration. The County Council shall then elect an individual to fill the vacancy or vacancies, which exist at that time in accordance with the voting procedures set forth in Rule 5.19. After an appointment(s) has been made, applications shall be retained by the Clerk of Council for one (1) year and may be considered upon the request of the applicant whenever a vacancy occurs within that one (1) year period of time.~~

COMMENT: *This doesn't seem like a place for this type of information. This seems more suited for the ordinance setting up the committee.*

- d) **Economic Development Committee**, consisting of three (3) members, serves to consider economic development matters brought before them and make recommendations to the full Council. The Committee meets on an as needed basis.

Absent exigent circumstances, no meeting of a standing committee of council shall be scheduled at the same time as another meeting of a standing committee of council.

5.8 Motions During Debate *(see below for comments)*

When a motion has been stated and seconded and debate has begun, the following motions shall be in order:

- a) To approve (the matter under consideration);
- b) To deny;
- c) To amend;
- d) To substitute one more (related to the matter) for another;
- e) To adjourn;
- f) To recess;
- g) To continue or postpone the matter to a date certain;
- h) To continue or postpone the matter indefinitely;
- i) To return to the agenda if the item under consideration has been taken out of turn;
- j) To table the matter;
- k) To call for the question ("close debate" or move "for the previous question");
- l) To raise a question of privilege;
- m) To convene an executive session;
- n) To refer the matter to a committee (or "to commit");
- o) To recommit a matter (send back to committee);
- p) To divide the question;
- q) To strike some or all of the matter (similar to substitute motion or amendment); and
- r) To seek information of "clarification" on an aspect of the matter under debate.

5.9 Substitute Motion

No more than two (2) motions may be received in substitute for the motion on the floor. Any substitute motion defeated by vote of Council shall be counted as one of two (2) permissible substitute motions, but any substitute motion, which fails for lack of a second, shall not be so counted.

5.10 Amendments

A proposed amendment shall be in order regardless of the number of changes proposed therein to the matter under debate, provided such amendment is otherwise in order, and shall be considered in the order in which it is received.

5.11 Withdrawing Motions

The member who introduced a motion may withdraw it before a decision on it or on any amendment to it, so long as the member seconding the motion shall not object; provided, however, that no motion may be withdrawn after the previous question has been called.

5.12 Privileged Motions

Motions to adjourn, to recess, to raise a question of privilege, to convene an executive session, or to return to the agenda if an item is taken out of turn shall always be in order except while the Council is actually engaged in deciding a question. A motion to adjourn or to take a recess, having been defeated, no new motion to adjourn or take a recess shall be in order until fifteen (15) minutes shall elapse from the decision of the former motion even though such motion to recess might be to recess to a different time.

5.13 Suspending Motions

The following instances may suspend any matter before Council, temporarily:

- 1) Point of order;
- 2) Point of personal privilege;
- 3) Point of information;
- 4) Question of recess; and

Other incidental questions, such as of reading papers, dividing a question, withdrawing a motion, or excusing a member from voting.

COMMENT on 5.8-5.12: *Recommend removal as it doesn't change Robert's Rules. I would recommend a motion cheat sheet and a general parliamentary procedure training. If you'd prefer to add some of these rules back, I suggest the Model Rules version, or a version thereof.*

5.18 Voting for Board and Committee Appointments

This method of voting is to be used solely in circumstances where Council is called upon to vote on the appointment of members of boards, commissions or similar entities where there are more nominees under consideration than there are vacancies to fill. Any Council member may make a motion to request a candidate be voted on individually.

This rule combines a recognition of the fact that plurality voting may be unavoidable in the initial stages of voting when considering a greater number of nominees than there are vacancies to fill, and majority voting once the number of nominees is drawn down to equal the number of vacancies by virtue of the voting process set forth herein.

Due to the complexity of this unusual but not unforeseeable situation, an example may be instructive.

Ex. If there are two (2) vacancies on a County board, and there are five (5) nominees, each Council member would be permitted to cast a vote for two (2) of the five (5) nominees to fill the two (2) vacancies.

In this event, the voting procedure shall be as follows:

- a) Each Council member shall be allowed to cast the same number of votes as there are vacancies to be filled. By way of further example, if three (3) vacancies exist, then each Council member would be permitted to vote for up to three (3) nominees, regardless of the total number of nominees.
- b) The Clerk to Council shall tabulate the votes.
- c) The nominee with the fewest votes will be removed from the slate of nominees, and the remaining nominees will be voted upon in what would be the next round of voting, with rounds to continue until enough nominees have been eliminated from consideration so that the number of nominees remaining equals the number of vacancies to be filled.
- d) If there is a tie among those with the fewest votes, then all nominees who are tied will be removed from the slate of nominees, and the remaining nominees will be voted upon in what would be the next round of voting. Provided, however, if so many of the nominees are tied for the least votes, and dropping all of them from the remaining slate of nominees would result in not having enough nominees to fill all of the vacancies, then there shall be a runoff among all of the nominees so tied for fewest votes. The candidate with the fewest votes in the runoff will be dropped from the slate of nominees that had been tied for fewest votes. Once at least one of the originally tied nominees for fewest votes is eliminated by runoff among the fewest vote-getters, those remaining among the originally tied voters will be placed back among the nominees who did not receive the fewest votes, and voting shall continue in this fashion by round until there are the same number of nominees as there are vacancies [e.g. three (3) nominees remaining for three (3) vacancies].
- e) Once Council arrives at a "slate" of nominees corresponding to the number of vacancies to be filled, it is in order for any member of Council to "nominate the slate" of nominees, which shall then be voted upon by Council in the form of a motion to approve the slate by "yea" or "nay," recorded electronically unless the electronic voting system is then inoperable or it is impractical to so vote. In this case, voting by show of hands shall be in order. The slate of nominees shall be approved by majority vote of Council members present and voting.

COMMENT: *I find this summary very confusing. I suggest the below language.*

Voting to Elect Boards, Committees, and Commissions. When council is voting to elect one or more persons to open positions on a board, committee, or commission, ballot elections should be used if the number of candidates exceeds the number of positions available. With a ballot election, each council member shall vote—on one ballot—for up to as many positions as are open. Each member shall sign or otherwise mark his or her ballot and the minutes will reflect each member's vote. Members may vote by ballot for someone who was not nominated. Each

ballot is considered one vote cast, and a candidate must receive a majority of votes to be elected. If no candidate receives a majority vote, balloting continues as needed until all positions are filled. If fewer than the proper number of candidates receive a majority vote, those candidates receiving a majority are elected, and balloting continues with all other candidates remaining on the ballot. If more candidates receive a majority vote than there are positions open, those receiving the largest number of votes will be elected and those receiving a majority, but tied for last of those receiving a majority, will remain on the ballot for repeat balloting, as needed. If all positions are not filled after the first vote, no candidates shall be involuntarily eliminated.

Richland County Council Request for Action

Subject:

Internal Audit Position

Notes:

October 18, 2022 – The Rules & Appointments Committee recommended to draft a job description for the Internal Auditor position, advertise for the position and then hire an Internal Auditor. The Employee Evaluation and Oversight Ad Hoc Committee should lead this endeavor.

Richland County Council Request for Action

Subject:

Criteria, Application and Schedule for Community Impact Grant Funds

Notes:

October 18, 2022 – The Community Impact Grants Committee recommended Council accept staff’s recommended time schedule for the Community Impact Grant Funds.

Recommended Schedule:

November 2-15, 2022	Communication for Notice of Intent to Award Funds
November 15, 2022	Grant Application Period Opens
December 16, 2022	Grant Application Period Closes
December 19-30, 2022	Committee Review and Recommendations
January 3-6, 2023	Notification of Awards
June 30, 2023	Deadline to expend funds



Informational Agenda Briefing

Prepared by:	Lori J. Thomas	Title:	Assistant County Administrator
Department:	Administration	Division:	Click or tap here to enter text.
Date Prepared:	October 10, 2022	Meeting Date:	October 18, 2022
Approved for consideration:	Choose an item.	Choose an item.	
Meeting/Committee	Community Impact Grants Committee		
Subject:	Proposed Scheduling Options for Community Impact Grants for Fiscal 2023		

BACKGROUND:

During the fiscal 2023 budget process, a County Council approved the allocation of \$300,000 to the discretionary grant funding for distribution during fiscal year 2023.

At the July 19, 2022 County Council meeting, the Rules and Appointments Committee recommended to rename the Discretionary Grant Committee to the Community Impact Grant Committee and add additional Council members to the committee. The Committee, pursuant to Council’s budget motion to allocate an additional \$300,000 to the committee, would and develop a process that creates accountability and transparency. The recommendation received unanimous approval by Council.

PROPOSED SCHEDULE

As the Community Impact Grant Committee considers its procedures and process, below is a proposed timeline for consideration for the award of the additional \$300,000 allocated in the 2023 budget using the guidelines and process from the FY 2023 Discretionary Grants:

If the Committee desires changes to the former Discretionary Grant Guidelines to award these funds, approval of criteria must be presented for Council consideration at its November 01, 2022 meeting.

This would require that the Community Impact Grant Committee have recommendations prepared for Council approval no later than October 25, 2022 to appear on full Council agenda on November 1, 2022.

November 2-15, 2022	Communication for Notice of Intent to Award Funds
November 15, 2022	Grant Application Period Opens
December 16, 2022	Grant Application Period Closes
December 19-30, 2022	Committee Review and Recommendations
January 3-6, 2023	Notification of Awards
June 30, 2023	Deadline to expend funds

As always, staff stands ready to support Council in their efforts to assist all Richland County citizens.

ATTACHMENTS:

1. Council Minutes – July 19, 2022
2. Council Motions List – June 7, 2022



COMMUNITY IMPACT GRANT GUIDELINES

FY2023 (July 1, 2022 – June 30, 2023)

Second Round of Grant Cycle will open November 15, 2022

Application must be submitted in ZoomGrants

Grant Application Due Date: December 15, 2022, by 11:59 PM

PROGRAM DESCRIPTION

Richland County Council has approved \$300,000 of the General Operating Fund for the FY2022-23 Community Impact Grant Fund. This program is designed to provide financial support to organizations and agencies that carry out community-based programs and/or services throughout Richland County. In keeping with the mission of Richland County Government, this program attempts to encourage organizations to continue to offer innovative and much-needed services that enhance the quality of life for all citizens of this County.

NOTE: The grant award must be expended between January 2023 and June 30, 2023. The unused funds will be forfeited and will not be available for reimbursement of expenditures incurred after June 30, 2023. Organizations that have received one-year discretionary general operating funds in the first round of FY22-23 will not be eligible to receive additional funds from this grant program.

COMMUNITY IMPACT GRANT TIMELINE

Request for Applications:	November 15, - December 15, 2022
Application Due Date:	December 15, 2022, 11:59 pm
Grant Award Notifications:	Early January 2023
Grant Period:	January – June 30, 2023
Final Reports:	Due by July 31, 2023 (if awarded)

PROGRAM ELIGIBILITY AND DESIGN

Organizations that are determined as charitable under Section 501(c)(3) of the Internal Revenue Code and nonprofit organizations registered as a charity with the Secretary of State. **Richland County will not award grants to individuals, fraternal organizations and organizations that support and/or endorse political campaigns.**

Religious organizations may receive funding; however, Richland County may not sponsor nor provide financial support to a religious organization in a manner which would actively involve it in a religious activity (i.e. public funds must not be used for a religious purpose). Thus, any funds provided must be solely utilized for secular purposes and the principal or primary goal of the sponsored activity must not be to advance religion.

The program fund is set up into two categories: (Make sure you select one on your application.)

1. One Year Funding - Organizations can apply for funding up to \$15,000. **If the organization is funded, the organization may apply for funding in the next fiscal year but not before.** If you received One-Year funding in the first round of FY22-23, you may not apply for this round of funding.
2. Multiple Year Funding - An organization with a startup program* or an organization requesting funds for a one-time capital project can apply for funding up to three years with the understanding that, if funded, the organization would receive funding in equal annual appropriations. After the final year, the organization will follow the one-year funding rule. The amount that can be applied for is up to \$30,000 meaning that if awarded, the organization will receive up to \$10,000 per year for up to three years. This allows Richland County to provide financial assistance to more local organizations throughout the County over a period of time. Please note that allocations are distributed as budgeted and organizations will not receive all multi-year funds up front.

If an organization is awarded a multiple year grant, the organization must re-submit a continuation application each year of appropriation. (*A startup program is a program that has been in existence 5 years or less.)

Grantee organizations may not re-grant or sub-granting County funds to other organizations. All funds must be spent on direct program expenditures by the organization who is granted the allocation.

PROGRAM REQUIREMENTS

- Organizations must apply to be considered for funding each year.
- Organizations must apply for either a one, two or three year funding option.
- Organizations receiving Accommodation Tax funds will not be considered for funding, unless waived by majority vote of Council.
- Richland County Council shall make all awards pursuant to this grant program.

PROGRAM CRITERIA (proposed request must address one of the following)

- The activity meets service-type activities outlined in the organization's mission, long-range plans, goals and objectives.
- The activity, in whole or in part, provides opportunities for underserved populations in Richland County.
- The activity provides solutions by way of systems or approaches that can prevent, mitigate or resolve individual, family, or community problems.

THE PROGRAM WILL NOT FUND (however, not limited to):

- Fundraising Projects
- Debt Reduction
- Endowment Development
- Medical Research/Health Related Issues
- Conference Travel
- Conference Underwriting or Sponsorship
- Gift Cards

GRANT APPLICATION

The grant application must be submitted in ZoomGrants through Richland County's website. Make sure all fields are completed as incomplete applications will not be reviewed by the Committee. Contact the Grants Manager if you have any difficulties completing the application. Once complete, save a copy and print for your records.

If you cut and paste information from Word, make sure your information is not cut off. The application components are as follows:

- Mission Statement – Include the organization's mission statement as found in your bylaws. You may also include any long-range plans and goals for your agency as a whole.
- Organization Background – Demonstration of recent accomplishments and success with programs similar to the one in your application.
- Project Description – This is the "meat" of the application where you describe your project – who, when, what, why and where.
- Benefit to the Community – Detail who is being served by your project, geographic location of your audience, how the project impacts the community.
- Collaborative Partners/Efforts – Describe how your organization will work with others on this project. What are partner's roles and are they on board?
- Outcomes – Share what result do you want to achieve and how will you measure success?

PROGRAM BUDGET

A budget section is provided for you as part of the application. This section applies only to the project outlined in the application. Please note that all grant funds must be expended by the recipient organization. Re-granting or sub-granting of funds is not allowed.

Expenditures must be consistent with the application budget. Only goods and services that comply with the Community Impact Grant Guidelines are permitted. The budget should reflect in financial terms the actual costs of achieving the

objectives of the project(s) you propose in your application.

Amounts listed in the Community Impact Grant Request column should total the amount of funds requested in the application. Please make sure that all expenses in the Community Impact Grant column relate to the proposed project outlined in the Project Description.

Note that there are blank spaces in the budget section of the application to provide additional expense categories as all budgets are not the same. Feel free to use these additional blank expense spaces for other categories not listed. For example, your project may have a transportation component. You can add a budget category these types of expenses.

Under project revenues, list known and anticipated funding sources, including any that are pending. Also include any in-kind contributions under project revenues. This section shows the Committee if your organization or others are contributing to the project outlined in the application. Attach copies of pending grants documentation (grant award letters) in the documents section of the grant application.

Please do not include agency administrative costs or organizational overhead expenses in your grant budget. All expenses should directly relate to the project or program that is outlined in the application.

Budget Narrative (Grant Funds Only) - Please include a brief 1-2 sentence description for each category included in the program budget. Make sure expenses are reflected in the project description. For example:

Contractual – 2 consultants to work 10 hours at \$25/hour to conduct 5 financial training workshops

Program expenses - \$500 for financial training workshop curriculum, \$500 rental fee for training space

APPLICATION PACKAGE

In order to be considered for funding, applicants must submit a complete application package for the Community Impact Grant program in ZoomGrants. Incomplete applications will not be considered. Complete applications include:

- 1) Completed and electronically initialed application. You can complete the application at:
<https://zoomgrants.com/gprop.asp?donorid=2236>
 - Answer all questions and complete each section. “N/A” and “See Attached” are not valid responses.
 - Electronic Initials by board chair or the executive director is requested in ZoomGrants - If your organization does not have an Executive Director, please note this in the application.
- 2) Project Budget and Narrative (form included with the application)
- 3) Required Attachments:
 - Current organization operating budget reflecting sources and amounts of income and expenditures for the organization as a whole, not just the program outlined in the application.
 - IRS determination letter indicating the organization’s 501 c 3 charitable status
 - Proof of current registration as a charity with the SC Secretary of State’s Office.
 - Current list of board of directors
 - Most recent 990 tax return. If you file a 990 post-card please also attach a financial report showing financial status.
 - Pending grant award documents such as grant award letters, emails or correspondence from the grantor.
 - Richland County business license or business license assessment survey form (this form shows that a business license is not needed for your organization).

Attachments MUST be submitted in ZoomGrants along with the proposal in order to be considered complete.

APPLICATION EVALUATION

Grant applications are reviewed by the Community Impact Grant Committee. The Committee will use the following evaluation criteria to evaluate applications and proposed projects. The individual factors are important in project evaluation, as they are an indication of the degree to which the proposed project will contribute to the citizens in Richland County. Make sure these factors are incorporated into your application. These factors, with their corresponding point values, are:

Project Summary: (Up to 35 Points)

- Does the proposal state an objective and does the objective fit the mission and long-range plans, goals
Community Impact Grant Fund Distribution

and objectives of the organization?

- Does the proposal provide a strong sense of need for the project/program and does it state what the funds will be used for?
- Does the proposal address who will be served and how many?
- Does the proposal state what will be the benefit to persons served?
- Does the proposal state a targeted underserved population?
- Does the proposal provide a program to prevent, mitigate or resolve individual, family, or community problems?
- Does the proposal state how the program will be evaluated once completed?

Project Impact: (Up to 30 Points)

- Is the proposal clear about how the project will work?
- Is there a timeframe outlined in the proposal; is the project ready to start?
- Are all aspects of the project feasible?
- Does the project provide a solution for the identified problem?
- Is the project innovative and provides solutions to problem?

Organization Background: (Up to 20 Points)

- Historical or current program experience indicated.
- Historical experience with targeted population addressed.
- Evidence of other successful experience relevant to the success of this proposal.
- Evidence of capable staff to carry out program/project.
- Does organization history indicate collaborative efforts with other entities?

Budget: (Up to 15 Points)

- Is the budget detailed and understandable?
- Is there another confirmed source of revenue to assist with this project/program?
- Is the project cost reasonable?
- Does budget incorporate any in-kind cost participation?
- Does the budget expense detail section include detailed cost calculation data (e.g., specific cost/quantity for personnel, supplies, travel) and information showing how County grant funds will be spent?

DEADLINE

Richland County will accept proposals in ZoomGrants starting **Tuesday, November 15, 2022**. These applications are available at <https://zoomgrants.com/gprop.asp?donorid=2236>. Applications are due **Thursday, December 15, 2022, at 11:59 P.M.** Proposals received *after* this date and time will not be considered. Fax and email transmissions **will not** be accepted.

AWARD NOTIFICATION

The Grants Manager will notify all applicant organizations of the funding outcome in writing in January 2023. Awards will be available for reimbursement beginning February 1, 2023. Final reports for the previous fiscal year, if applicable, must be received before payments are released.

REPORTING REQUIREMENTS

At the completion of the grant-funded project, Richland County requires grantees to complete a mid-year and/or a final report for Community Impact Grant funds. Grantees are required to show proof of grant expenditures (invoices and proof of payment). Grantees are asked to report on attendance/impact numbers, program success or failure as well as the impact on Richland County. Each grantee will receive a copy of or a link to the reporting documents with their award packet and reports will also be sent via email.

Grantees must acknowledge the receipt of Community Impact Grant funding by including the Richland County Government logo, or by listing "Funding Provided by Richland County Government" on program/project advertising, marketing and promotional materials, website or in the organization's annual report. Examples of this must be included in your final report.

FREEDOM OF INFORMATION ACT NOTICE

Please be advised that all materials submitted on behalf of the Community Impact Grant program are subject to disclosure based on the Freedom of Information Act (FOIA).

- No person, based on race, color, national origin, religion, age, sex, ancestry, gender identity (including gender expression), sexual orientation, disability, age, marital status, family/parental status, income derived from a public assistance program, political beliefs, veteran status, military discharge status, citizenship status or reprisal or retaliation for prior civil rights activity should be excluded from participation in be denied the benefit of or be otherwise subjected to discrimination under the program or activity funding in whole or in part by Community Impact Grant funds.
- Employment made by or resulting from Community Impact Grant funding shall not discriminate against any employee or applicant on the basis on race, color, national origin, religion, age, sex, ancestry, gender identity (including gender expression), sexual orientation, disability, age, marital status, family/parental status, income derived from a public assistance program, political beliefs, veteran status, military discharge status, citizenship status or reprisal or retaliation for prior civil rights of handicap, age, race, color, religion, sex, or national origin.
- None of the funds, materials, property, or services provided directly or indirectly under Community Impact Grant funding shall be used for any partisan political activity, or to further the election or defeat of any candidate for public office.

QUESTIONS

Please call Ms. Matiah Pough, Grants Manager at (803)576-5459 or email Pough.Matiah@richlandcountysc.gov.

THIRD READING BUDGET MOTIONS LIST FY 2022-23

Item	Sponsor	Page	Fund	Department Impacted	Item/Action	Council's Determination of Amount Needed	Notes	FY23 Second Reading Amt.	FY23 Second Reading Action	FY23 Third Reading Amount	FY23 Third Reading Action
1: MILLAGE AGENCIES											
1	Administration	76	Millage Agency	RC Recreation Commission	Approve Agency's budget request as received (Approved at No Mill Increase level)	Yes	Request Mill Cap - Est Additional Cost per 100K homeowner value \$3.00. Mill Cap = 16,063,900	\$ 16,063,900	\$ 15,362,500	\$ 15,362,500	
2	Administration	76	Millage Agency	Columbia Area Mental Health	Approve Agency's budget request as received (Approved at No Mill Increase level)	Yes	Request Mill Cap - Est Additional Cost per 100K homeowner value \$1.00. Mill Cap = 2,584,000	\$ 2,584,000	\$ 2,408,000	\$ 2,408,000	
3	Administration	76	Millage Agency	RC Public Library	Approve Agency's budget request as received (Approved at No Mill Increase level)	Yes	Request Mill Cap - Est Additional Cost per 100K homeowner value \$4.0. Mill Cap = 30,868,000	\$ 30,868,000	\$ 29,460,000	\$ 29,460,000	
4	Administration	76	Millage Agency	Riverbanks Zoo and Gardens	Approve Agency's budget request as received (Approved at No Mill Increase level)	Yes	Request No Mil Increase	\$ 2,574,000	\$ 2,574,000	\$ 2,574,000	
5	Administration	76	Millage Agency	Midlands Tech. College (Operating)	Approve Agency's budget request as received (Approved at No Mill Increase level)	Yes	Request Mill Cap - Est Additional Cost per 100K homeowner value \$2.0. Mill Cap = 7,250,700	\$ 7,250,700	\$ 6,898,100	\$ 6,898,100	
6	Administration	76	Millage Agency	Midlands Tech Capital/Debt Service	Approve Agency's budget request as received (Approved at No Mill Increase level)	Yes	Request Mill Cap - Est Additional Cost per 100K homeowner value \$1.0. Mill Cap = 3,861,000	\$ 3,861,000	\$ 3,685,000	\$ 3,685,000	
7	Administration	76	Millage Agency	School District One	Approve Agency's budget request as received (Approved at No Mill Increase level)	Yes	Request No Mil Increase	\$ 239,797,217	\$ 239,797,217	\$ 239,797,217	
8	Administration	76	Millage Agency	School District Two	Approve Agency's budget request as received (Approved at No Mill Increase level)	Yes	Agency's request = \$175,649,721. Est Additional Cost per 100K homeowner value \$111.0. The revised Mill Cap level of \$177,549,921	\$ 169,467,321	\$ 169,467,321	\$ 175,649,721	
2: GRANTS											
9	Administration	31,32	Special Revenue	Accommodations Tax Grants	Approval of A-Tax Committee Recommendations		This is the total value of all committee recommendations. Exclude \$30,000 awarded to Lake Murray Capital City (re: Item #25)	\$ 400,000	\$ 400,000	\$ 370,000	
10	Administration	33	Special Revenue	Hospitality Tax	Approval of Reserve for Future Years/Contingency funding level			\$ 150,000	\$ 150,000	\$ 150,000	
11	Administration	33	Special Revenue	Hospitality Tax	Approval of Transfers Out funding level		H-Tax Debt Service and Support of the General Fund	\$ 4,487,750	\$ 4,487,750	\$ 4,487,750	
12	Administration	34	Special Revenue	Hospitality Tax (Ordinance Agency)	Approval of the funding level for Columbia Museum of Art for FY23	Yes	Use of fund balance will be affected based on Council's recommendation	\$ 791,705	\$ 791,705	\$ 791,705	
13	Administration	34	Special Revenue	Hospitality Tax (Ordinance Agency)	Approval of the funding level for Historic Columbia Foundation for FY23	Yes	Use of fund balance will be affected based on Council's recommendation. Amount was increased by \$100,000 in second reading.	\$ 406,810	\$ 506,810	\$ 506,810	
14	Administration	34	Special Revenue	Hospitality Tax (Ordinance Agency)	Approval of the funding level for Edventure for FY23	Yes	Use of fund balance will be affected based on Council's recommendation	\$ 423,333	\$ 423,333	\$ 423,333	
15	English, Livingston	34	Special Revenue	Hospitality Tax (Ordinance Agency)	Approval of the funding level for Township Auditorium for FY23	Yes	Use of fund balance will be affected based on Council's recommendation	\$ 385,000	\$ 385,000	\$ 385,000	
16	Administration	34	Special Revenue	Hospitality Tax (Special Promotions)	Approval of the funding level for Columbia Metropolitan Convention Center and Visitor's Bureau at FY22 level	Yes	Use of fund balance will be affected based on Council's recommendation	\$ 201,091	\$ 201,091	\$ 201,091	
17	Administration	34	Special Revenue	Hospitality Tax (Special Promotions)	Approval of the funding level for Columbia International Festival at FY22 level	Yes	Use of fund balance will be affected based on Council's recommendation	\$ 166,344	\$ 166,344	\$ 166,344	

Item	Sponsor	Page	Fund	Department Impacted	Item/Action	Council's Determination of Amount Needed	Notes	FY23 Second Reading Amt.	FY23 Second Reading Action	FY23 Third Reading Amount	FY23 Third Reading Action
18	Administration	34	Special Revenue	Hospitality Tax (Tier 3)	Approval of SERCO funding at FY22 level	Yes	Use of fund balance <u>will be affected</u> based on Council's recommendation. <u>Data input error</u> in the second reading amount. FY22 approved funding was \$67,895.	\$ 150,000	\$ 150,000	\$ 67,895	
19	Administration	34	Special Revenue	Hospitality Tax (Council Advocacy Groups)	Approval of carry over any unexpended funds from the Gateway Pocket Park/Blight Removal Project to FY23 budget	Yes	Use of fund balance <u>will be affected</u> based on Council's recommendation	\$ 250,000	\$ 250,000	\$ 250,000	
20	Administration	34	Special Revenue	Hospitality Tax (Council Advocacy Groups)	Approval of carry over any unexpended funds from the Historical Corridor to FY23 budget	Yes	Use of fund balance <u>will be affected</u> based on Council's recommendation. \$125,000 are encumbered in FY22. The remaining balance is updated.	\$ 372,715	\$ 372,715	\$ 247,715	
21	Administration	34 to 40	Special Revenue	Hospitality Tax (Council Advocacy Groups)	Approval of H-tax Committee Recommendations		This is the total value of all committee recommendations. Exclude \$50,000 awarded to Lake Murray Capital City (re: Item #25)	\$ 500,000	\$ 500,000	\$ 450,000	
22	Administration	34	Special Revenue	Hospitality Tax (Council Advocacy Groups)	Approval of Councilmember H-Tax Discretionary funding level	Yes	\$ 82,425 per Council District. Use of fund balance <u>will be affected</u> based on Council's recommendation	\$ 906,675	\$ 906,675	\$ 906,675	
23	English, McBride	38	Special Revenue	Hospitality Tax (Council Advocacy Groups)	Approve funding of \$60,000 to the Lower Richland Sweet Potato Festival for their annual festival in FY23	Yes	<ul style="list-style-type: none"> Use of fund balance <u>will be affected</u> due to this motion. The festival brings over 14,000 attendees from across the United States for over 40 years. 	\$ 60,000	\$ 60,000	\$ 60,000	
24	McBride	34	Special Revenue	Hospitality Tax (Council Advocacy Groups)	Approval of carry over any unexpended funds from each Councilmember District to FY23 budget	Yes		N/A	Passed	N/A	
25	MALINOWSKI and LIVINGSTON	34	Special Revenue	Hospitality Tax (Special Promotions)	Approval Lake Murray Capital City as a Special Promotion Agency and appropriate funding	Yes	<ul style="list-style-type: none"> Use of fund balance <u>will be affected</u> due to this motion. This entity is one of only 2 tourism promotional agencies approved by the state to bring tourism to the Midlands Region, including Richland County. They consistently promote Richland County via worldwide media with advertising and entertainment events 	TBD	\$ 150,000	\$ 150,000	
26	Administration	41 to 44	Special Revenue	Neighborhood Redevelopment	Approval of Neighborhood Improvement Grant Recommendations		This is the total value of all committee recommendations	\$ 75,775	\$ 75,775	\$ 75,775	
27	Administration	45 to 46	Special Revenue	Conservation Commission	Approval of RC Conservation Commission Grant Recommendations		This is the total value of all committee recommendations	\$ 250,000	\$ 250,000	\$ 250,000	
28	Administration	47 to 53	Special Revenue (Grant Revenue)	Various Grant Funded Depts.	Approval of department requests that are applying for external grants in FY23 and required matching of County funds		Departments requesting approval of applying various grants for totaling incoming potential revenue of \$105,231,142 including associated matching of County funds: <ul style="list-style-type: none"> \$456,562 in General Funds \$3,053,500 in Enterprise Funds 	\$ 105,231,142	\$ 105,231,142	\$ 105,231,142	
3: GENERAL FUND											
29	Administration	8	General Fund (Revenue)	County Departments	Approve Projected General Fund Revenue as presented in the FY23 Recommended Budget Book			\$ 189,747,431	\$ 189,747,431	\$ 189,747,431	
30	Administration	8	General Fund (Revenue)	County Departments	Approve General Fund Transfers In as presented in the FY23 Recommended Budget Book			\$ 3,025,000	\$ 3,025,000	\$ 3,025,000	
31	Administration	8	General Fund (Revenue)	County Departments	Approve Projected Use of General Fund Balance to support overall General Fund expenditure as presented in the FY23 Recommended Budget Book		The original projected Use of GF Balance is increased by \$611,000 to \$4,603,503	\$ 3,992,503	\$ 3,992,503	\$ 4,603,503	

Item	Sponsor	Page	Fund	Department Impacted	Item/Action	Council's Determination of Amount Needed	Notes	FY23 Second Reading Amt.	FY23 Second Reading Action	FY23 Third Reading Amount	FY23 Third Reading Action
32	Administration	5	General Fund (Expenditure)	County Departments	Approve change in the County's health insurance carrier from Cigna Health Care to the SC State Health Plan (PEBA)		This change will still provide quality healthcare to staff and enrolled retirees with a savings to the County of an estimated \$3,698,357, an estimated savings to employees of \$909,497 for FY 2023 and \$40,254,743 over five years for reinvestment in employees and other County wide needs.	\$ (3,698,357)	\$ (3,698,357)	\$ (3,698,357)	
33	Administration	5	General Fund (Expenditure)	County Departments	Approve increasing the minimum entry-level annual wage to \$32,210 (\$16.52 per hour) for full-time and part-time positions to be implemented by August 5,2022			\$ 712,197	\$ 712,197	\$ 712,197	
34	Administration	5	General Fund (Expenditure)	County Departments	Approve 4% pay raise for Richland County's full-time and part-time employees excluding certified detention officers to be implemented by September 2, 2022			\$ 4,281,128	\$ 4,281,128	\$ 4,281,128	
35	Administration	5	General Fund (Expenditure)	County Departments	Approve on average 7.24% pay raise for Richland County's certified detention officers to be implemented by September 2,2022			\$ 943,119	\$ 943,119	\$ 943,119	
36	Administration	5	General Fund (Expenditure)	County Departments	Approve independent Procurement Department			N/A	Passed	N/A	
37	Administration	5	General Fund (Expenditure)	County Departments	Approve independent Grant Department		New Grant Director position is included in recommended new positions list	N/A	Passed	N/A	
38	Administration	7	General Fund (Expenditure)	County Departments	Approve General Fund Overall Personnel, Operating and Capital Expenditures as presented in the FY23 Recommended Budget Book			\$ 183,258,963	\$ 183,258,963	\$ 183,258,963	
39	Administration	7	General Fund (Expenditure)	Transfer Out	Approve General Fund Operating Transfers Out as presented in the FY23 Recommended Budget Book		General Fund support of other Funds; Amounts will increase/decrease per Council Motions	\$ 10,395,758	\$ 10,395,758	\$ 10,395,758	
40	Administration	7,24,25	General Fund (Expenditure)	County Departments	Approve General Fund New Positions and Reclassifications requests by Departments as presented in the FY Recommended Budget Book		<ul style="list-style-type: none"> • 13 New positions totaling fiscal impact \$872,126 • 3 Reclassification of current positions \$27,951 (already accounted in the department budget) 	\$ 872,126	\$ 872,126	\$ 872,126	
41	Administration	26	Other Funds - Expenditure (Special Revenue and Enterprise)	County Departments	Approve Other Fund New Positions requests by Departments as presented in the FY Recommended Budget Book		<ul style="list-style-type: none"> • 19 New positions totaling fiscal impact \$735,719 	\$ 735,719	\$ 735,719	\$ 735,719	
42	Administration	28 to 30	General Fund (Expenditure)	Discretionary Grant	Approve total of \$200,000 in discretionary grant committee recommendations		This is the total value of all committee recommendations.	\$ 200,000	\$ 200,000	\$ 200,000	
43	Mackey	28 to 30	General Fund (Expenditure)	Discretionary Grant	Approve additional \$300,000 in discretionary grant committee recommendations	Yes	<ul style="list-style-type: none"> • Use of fund balance will be increased due to this motion. • The Discretionary Grant Committee receives \$200,000 in the FY23 Budget and the committee has made funding recommendations based on the applications received. This motion would provide an additional \$300,000 for the committee to distribute in FY23. 	\$ 300,000	\$ 300,000	\$ 300,000	

Item	Sponsor	Page	Fund	Department Impacted	Item/Action	Council's Determination of Amount Needed	Notes	FY23 Second Reading Amt.	FY23 Second Reading Action	FY23 Third Reading Amount	FY23 Third Reading Action
44	Mackey	28	General Fund (Expenditure)	Contractual & Statutory Grant	Approve funding the Central Midlands COG for FY23	Yes	<ul style="list-style-type: none"> This will NOT increase the use of fund balance These organizations have historically been listed under Grants- Lump Sum Appropriations. Listing under this category heading is misrepresentative of how the organizations are funded; County Council is required to fund these organizations. 	\$ 200,826	\$ 200,826	\$ 200,826	
45	Mackey	28	General Fund (Expenditure)	Contractual & Statutory Grant	Approve funding the City Center Partnership for FY23	Yes	This will NOT increase the use of fund balance	\$ 47,500	\$ 47,500	\$ 47,500	
46	Mackey	29	General Fund (Expenditure)	Contractual & Statutory Grant	Approve funding the LRADAC for FY23	Yes	This will NOT increase the use of fund balance	\$ 600,000	\$ 600,000	\$ 600,000	
47	Mackey	28 to 30	General Fund (Expenditure)	Lump Sum Agencies	Provide priority consideration for remaining Lump Sum Appropriations agencies (that have requested funds) via ARPA funds (Community Grants and Public Private Partnerships) and/or additional Discretionary Grant funds.	Yes	Having agencies apply for funding via ARPA or Discretionary Grants creates accountability and transparency, and ensures that all organizations are going through the same process to be considered for funds. Organizations that have requested funds for FY23 will be given priority consideration during the applications review process for ARPA and Discretionary Grants.	N/A	Passed	N/A	
48	English, O. Walker	30	General Fund (Expenditure)	Lump Sum Agencies	Approve funding of \$20,000 to the Therapy Place towards its operating expenditure in FY23	Yes	Use of fund balance will be increased due to this motion.	\$ 20,000	\$ 20,000	\$20,000	
49	English, McBride	28	General Fund (Expenditure)	Lump Sum Agencies	Approve funding of \$81,000 to the Communities in Schools towards their program expenditure in FY23	Yes	<ul style="list-style-type: none"> Use of fund balance will be increased due to this motion. Communities in Schools works with all children within the schools they serve and capture those children who seeming fall through the cracks, but need services. Many of these children do not have mental health diagnoses, but have issues which hinder their development and educational process. 	\$ 81,000	\$ 81,000	\$81,000	
50	English, Pugh	11	General Fund (Expenditure)	Council Services	Approve increasing the amount of each Councilmember District's discretionary operating expenditure from \$10,000 to its previous amount of \$15,000	Yes	<ul style="list-style-type: none"> Use of fund balance will be increased due to this motion. Total increase of \$55,000 Funds from previous Councils were at \$18,000.00. They were then reduced several times (\$18,000.00, to \$15,000.00 to \$12,000.00. 	\$ 55,000	Failed	Withdraw	
51	Levingston	11	General Fund (Expenditure)	Council Services	Approve each Councilmember District's discretionary operating expenditure to its FY22 level of \$10,000	Yes	This will NOT increase use of fund balance	\$ 110,000	\$110,000	\$110,000	
52	McBride	28	General Fund (Expenditure)	Lump Sum Agencies	Approve funding the Antioch Senior Center for FY23	Yes	<ul style="list-style-type: none"> As previously funded in FY22. Use of fund balance will be increased due to this motion. 	\$ 40,000	\$ 40,000	\$ 40,000	
53	McBride	29	General Fund (Expenditure)	Lump Sum Agencies	Approve funding the Greenview Swim Team for FY23	Yes	<ul style="list-style-type: none"> As previously funded in FY22. Use of fund balance will be increased due to this motion. 	\$ 20,000	\$ 20,000	\$ 20,000	
54	McBride	30	General Fund (Expenditure)	Lump Sum Agencies	Approve funding the St. John CDC for FY23	Yes	<ul style="list-style-type: none"> As previously funded in FY22. Use of fund balance will be increased due to this motion. 	\$ 75,000	\$ 75,000	\$ 75,000	

Item	Sponsor	Page	Fund	Department Impacted	Item/Action	Council's Determination of Amount Needed	Notes	FY23 Second Reading Amt.	FY23 Second Reading Action	FY23 Third Reading Amount	FY23 Third Reading Action
55	McBride	30	General Fund (Expenditure)	Lump Sum Agencies	Approve to increase the Wiley Kennedy Foundation to \$75,000 in FY23 (increase of \$15k)	Yes	<ul style="list-style-type: none"> To expand and improve the juvenile delinquency prevention. Use of fund balance <u>will be increased</u> due to this motion. 	\$ 75,000	\$ 75,000	\$ 75,000	
56	English, J. Walker, Pugh	N/A	ARPA	County Departments (Public Safety)	Appropriate a contingency of up to \$3,000,000 of American Rescue Plan Funds for potential Public Safety initiatives. These funds would be a transfer to the General Fund on a reimbursement basis.	Yes	This will <u>NOT</u> increase use of fund balance as it will be funded from ARPA funds.	\$ 3,000,000	\$ 3,000,000	\$ 3,000,000	
57	Mackey, Pugh	28 to 30	ARPA	Lump Sum Agencies	<p>Move to fund the following organizations (listed in Lump Sum Appropriations) via ARPA funds up to \$1,150,000</p> <ul style="list-style-type: none"> Capital Senior Center \$180,000 Columbia Urban League \$100,000 Senior Resources \$548,046 Transitions Homeless Center \$100,000 Greater Columbia Community Relations \$95,250 Palmetto AIDS Life Support \$90,000 	Yes	<ul style="list-style-type: none"> This will <u>NOT</u> increase use of fund balance as it will be funded from ARPA funds. Palmetto AIDS Life Support's increase in FY23 due to SC HIV Aids Council closing (last year - \$70,000). In an effort to move towards more accountability and transparency, the Lump Sum Appropriations category of the County Budget should be eliminated and replaced with a process that allows all organizations to request funds via the same process. The County currently has several different categories for organizations to request and receive funds: Discretionary Grants, Hospitality, Accommodations, Neighborhood Improvement and ARPA funds. Each of these categories requires an application process. 	\$ 1,113,296	\$ 1,113,296	\$ 1,113,296	
4: SPECIAL REVENUE FUNDS											
58	Administration	55 to 63	Special Revenue	Economic Development	Appropriate funding to approve Economic Development Budget			\$ 3,527,095	\$ 3,527,095	\$ 3,527,095	
59	Administration	55 to 63	Special Revenue	Emergency Telephone System	Appropriate funding to approve Emergency Telephone System Budget			\$ 6,405,101	\$ 6,405,101	\$ 6,405,101	
60	Administration	55 to 63	Special Revenue	Fire Services	Appropriate funding to approve Fire Services Budget			\$ 31,067,584	\$ 31,067,584	\$ 31,067,584	
61	Administration	55 to 63	Special Revenue	Hospitality Tax	Appropriate funding to approve Hospitality Tax Budget			\$ 8,986,312	\$ 8,986,312	\$ 8,986,312	
62	Administration	55 to 63	Special Revenue	Accommodations Tax	Appropriate funding to approve Accommodations Tax Budget			\$ 425,000	\$ 425,000	\$ 425,000	
63	Administration	55 to 63	Special Revenue	Transportation Tax	Appropriate funding to approve Transportation Tax Budget			\$ 80,000,000	\$ 80,000,000	\$ 80,000,000	
64	Administration	55 to 63	Special Revenue	Neighborhood Redevelopment	Appropriate funding to approve Neighborhood Redevelopment Budget			\$ 909,330	\$ 909,330	\$ 909,330	
65	Administration	55 to 63	Special Revenue	Public Defender	Appropriate funding to approve Public Defender Budget			\$ 5,426,423	\$ 5,426,423	\$ 5,426,423	
66	Administration	55 to 63	Special Revenue	Title IVD - Sheriff's Fund	Appropriate funding to approve Title IVD - Sheriff's Fund Budget			\$ 55,563	\$ 55,563	\$ 55,563	
67	Administration	55 to 63	Special Revenue	School Resource Officers	Appropriate funding to approve School Resource Officers Budget			\$ 6,957,345	\$ 6,957,345	\$ 6,957,345	
68	Administration	55 to 63	Special Revenue	Victim's Assistance	Appropriate funding to approve Victim's Assistance Budget			\$ 1,276,505	\$ 1,276,505	\$ 1,276,505	
69	Administration	55 to 63	Special Revenue	Tourism Development	Appropriate funding to approve Tourism Development Budget			\$ 1,253,120	\$ 1,253,120	\$ 1,253,120	

Item	Sponsor	Page	Fund	Department Impacted	Item/Action	Council's Determination of Amount Needed	Notes	FY23 Second Reading Amt.	FY23 Second Reading Action	FY23 Third Reading Amount	FY23 Third Reading Action
70	Administration	55 to 63	Special Revenue	Temporary Alcohol Permits	Appropriate funding to approve Temporary Alcohol Budget			\$ 172,168	\$ 172,168	\$ 172,168	
71	Administration	55 to 63	Special Revenue	Stormwater Management	Appropriate funding to approve Stormwater Management Budget			\$ 3,732,147	\$ 3,732,147	\$ 3,732,147	
72	Administration	55 to 63	Special Revenue	Conservation Commission	Appropriate funding to approve Conservation Commission Budget			\$ 1,139,178	\$ 1,139,178	\$ 1,139,178	
73	Administration	55 to 63	Special Revenue	Road Maintenance	Appropriate funding to approve Road Maintenance Budget			\$ 8,193,572	\$ 8,193,572	\$ 8,193,572	
74	Administration	28, 57, 60, 64	Special Revenue	Stormwater Management	Approve funding the Congaree River Keeper for FY23		This expenditure is already budgeted in the Stormwater Services.	\$ 20,000	\$ 20,000	\$ 20,000	
75	Administration	30, 57, 59, 64	Special Revenue	Temporary Alcohol Permits	Approve funding the River Alliance for FY23		This expenditure is already budgeted in the Temporary Alcohol Permits.	\$ 53,000	\$ 53,000	\$ 53,000	
5: DEBT SERVICE											
76	Administration	73 & 74	Debt Service	General Obligation Debt Service	Appropriate funding to fund debt service			\$ 20,208,361	\$ 20,208,361	\$ 20,208,361	
77	Administration	73 & 74	Debt Service	Fire Bonds Debt Service	Appropriate funding to fund debt service			\$ 545,600	\$ 545,600	\$ 545,600	
78	Administration	73 & 74	Debt Service	Hospitality Refund 2013A B/S (Special Assessment)	Appropriate funding to fund debt service			\$ 1,487,750	\$ 1,487,750	\$ 1,487,750	
79	Administration	73 & 74	Debt Service	RC IP Bonds 2019	Appropriate funding to fund debt service			\$ 1,604,144	\$ 1,604,144	\$ 1,604,144	
80	Administration	73 & 74	Debt Service	School District I Debt Service	Appropriate funding to fund debt service			\$ 61,071,918	\$ 61,071,918	\$ 61,071,918	
81	Administration	73 & 74	Debt Service	School District II Debt Service	Appropriate funding to fund debt service			\$ 64,215,424	\$ 64,215,424	\$ 64,215,424	
82	Administration	73 & 74	Debt Service	Recreation Commission	Appropriate funding to fund debt service			\$ 3,769,189	\$ 3,769,189	\$ 3,769,189	
83	Administration	73 & 74	Debt Service	Riverbanks Zoo & Garden	Appropriate funding to fund debt service			\$ 2,556,463	\$ 2,556,463	\$ 2,556,463	
84	Administration	73 & 74	Debt Service	East Richland Public Service Dist. (Sewer)	Appropriate funding to fund debt service			\$ 1,438,561	\$ 1,438,561	\$ 1,438,561	
85	Administration	73 & 74	Debt Service	Transportation Bonds	Appropriate funding to fund debt service			\$ 14,433,250	\$ 14,433,250	\$ 14,433,250	
6: ENTERPRISE											
86	Administration	67	Enterprise	Solid Waste Enterprise Fund	Approve Proposed Increase in the FY23 Rate Schedule as presented by the Department in the Council Budget Work Session on May 5, 2022		New rate schedule is projected to generate additional \$3,012,909 revenue which will balance out Department's projected FY23 total expenditure of \$41,542,159	N/A	Passed	N/A	
87	Administration	67 to 71	Enterprise	Solid Waste Enterprise Fund	Appropriate funding to approve Solid Waste Budget			\$ 41,542,159	\$ 41,542,159	\$ 41,542,159	
88	Administration	29, 69, 71	Enterprise	Solid Waste Enterprise Fund	Approve funding the Keep the Midlands Beautiful for FY23		This expenditure is already budgeted in the Solid Waste Collection	\$ 42,900	\$ 42,900	\$ 42,900	
89	Administration	67 to 71	Enterprise	Richland County Utilities	Appropriate funding to approve Richland County Utilities Budget			\$ 13,820,000	\$ 13,820,000	\$ 13,820,000	
90	Administration	67 to 71	Enterprise	Hamilton-Owens Airport Operating	Appropriate funding to approve Airport Budget		Includes Transfer In from the GF: \$270,846	\$ 581,724	\$ 581,724	\$ 581,724	



Richland County Council
REGULAR SESSION
MINUTES
July 19, 2022 – 6:00 PM
Council Chambers
2020 Hampton Street, Columbia, SC 29204

COUNCIL MEMBERS PRESENT: Overture Walker, Chair; Jessica Mackey, Vice-Chair; Bill Malinowski, Derrek Pugh, Yvonne McBride, Paul Livingston, Joe Walker and Cheryl English

1. **CALL TO ORDER** – Chairman Overture Walker called the meeting to order at approximately 6:00PM.
2. **INVOCATION** – The Invocation was led by the Honorable Cheryl English.
3. **PLEDGE OF ALLEGIANCE** – The Pledge of Allegiance was led by the Honorable Yvonne McBride.
4. **APPROVAL OF MINUTES**
 - a. **Special Called: July 12, 2022** – Mr. Pugh moved to approve the minutes as distributed, seconded by Mr. J. Walker.

Mr. Malinowski noted Item 14(b) *“I move to have staff amend Section 26-186 (Development with Open Space Design Standards) of the Land Development Code by amending the formula used in determining the total number of units allowed in the utilization of density-based and density bonus design standards by subtracting the constrained open space area acreage from the total site acreage prior to calculating. In addition, all lots must conform to the DHEC minimum required sizes so no bonus allows that lot size to be less than the DHEC requirement [MALINOWSKI – January 4, 2022]”* was actually addressed, and subsequently approved, after Item 15(a) *“An Ordinance Amending Ordinance # 05-53.5-21 Amending the Richland County Code of Ordinances, so as to adopt the Richland County Land Development Code Rewrite; and to replace Chapter 26, Land Development amending the effective dates of its provision and clarification of interim procedures”*.

Mr. Wright stated it does not matter the order it is listed in the minutes, but that the action itself is recorded in the minutes.

Mr. Malinowski noted on p. 5 of the minutes the statement *“Mr. Wright responded the text was approved on November 16, 2022. The only thing that has not become effective are the maps.”* is not totally accurate. The Planning Commission is discussing the maps and additional text changes. He believes it is misleading to let the public think the only thing not effective are the maps.

Mr. Wright stated until the maps are completed there can be no adjustments to the text.

In Favor: Malinowski, Pugh, McBride, Livingston, J. Walker, O. Walker, Mackey and English

Not Present: Terracio, Barron and Newton

Regular Session
July 19, 2022

-1-

335 of 343

The vote in favor was unanimous.

5. **ADOPTION OF AGENDA** – Mr. Pugh moved to amend the agenda to add a Hospitality Tax allocation for District 5, seconded by Ms. English.

In Favor: Malinowski, Pugh, McBride, Livingston, J. Walker, O. Walker, Mackey and English

Not Present: Terracio, Barron and Newton

The vote in favor was unanimous.

6. **REPORT OF THE ATTORNEY FOR EXECUTIVE SESSION ITEMS** – There were no items for Executive Session.

7. **CITIZENS' INPUT**

a. **For Items on the Agenda Not Requiring a Public Hearing**

1. Robert Reese, 204 Sonoma Drive, Hopkins, SC 29061 – G.A.N.G.S in Peace Initiative
2. Thomas Williams, 1528 Willow Oak Drive, Columbia, SC 29223 – G.A.N.G.S in Peace Initiative
3. Kaylin Jones, Gingerroot Way – G.A.N.G.S in Peace Initiative
4. Linda Maxwell, 511 Alcott Drive, Columbia, SC 29203 – G.A.N.G.S in Peace Initiative
5. Levar Baker, 309 Peppercorn Lane, Columbia, SC 29223 – G.A.N.G.S in Peace Initiative
6. Alonzo Canzater, 822 Swygert Road, Blythewood, SC 29016 – G.A.N.G.S in Peace Initiative
7. Jay Brown, 18 Berryhill Road, Columbia, SC 29210 – G.A.N.G.S in Peace Initiative
8. Torian Sims, 537 Lake Carolina Boulevard, SC 29229 – G.A.N.G.S in Peace Initiative
9. Lolita Frazier, 220 Springtree Road, Columbia, SC 29223 – G.A.N.G.S in Peace Initiative
10. Jamar Smith, 250 Crossmore Drive, Columbia, SC 29212 – G.A.N.G.S in Peace Initiative
11. Darryl Sutton, 3912 Pine Cone Drive, Columbia, SC 29204 – G.A.N.G.S in Peace Initiative
12. Malachi Amant, 341 Percival Road, Columbia, SC 29206 – G.A.N.G.S in Peace Initiative
13. Ann Mickle, 129 Island View Circle, Elgin, SC 29045 – G.A.N.G.S in Peace Initiative
14. LaKenyatta Maxwell, 118 Crawford Court, Columbia, SC 29203 – G.A.N.G.S in Peace Initiative
15. Bishop Eric Davis, 22 Keeneland Trail, Blythewood, SC 29016 – G.A.N.G.S in Peace Initiative

8. **CITIZENS' INPUT**

- a. **Must Pertain to Richland County Matters Not on the Agenda (Items for which a public hearing is required or a public hearing has been scheduled cannot be addressed at this time)** – No one signed up to speak.

9. **REPORT OF THE COUNTY ADMINISTRATOR**

- a. **Coronavirus Update** – No update was given.
- b. **Other Updates** – Mr. Brown introduced the new Detention Center Director, Tyrell Cato.
- c. **FY2022-2023 Five Year Consolidated Plan: FY2022 Annual Action Plan** – Mr. Brown stated the proposed submission to HUD relative to the CDBG and HOME programs. The proposed submission will go through a public display period. When Council comes back in August, we will be looking for Council to address the matter.

Ms. McBride inquired if this is the federally mandated plan that has to be submitted in order for the County to receive CDBG funds to address homelessness and infrastructure areas.

Mr. Brown responded in the affirmative.

10. **REPORT OF THE CLERK OF COUNCIL** – Ms. Kirylo reminded Council of the Special Called meeting scheduled for July 26th at 7:45 PM.

**Regular Session
July 19, 2022**

-2-

336 of 343

11. **REPORT OF THE CHAIR** – No report was given.

12. **SECOND READING ITEMS**

- a. An ordinance amending the School Resource Officer line item in the FY2023 Budget Ordinance (No. 012-22HR) of Richland County, South Carolina – Mr. Livingston moved to approve this item, seconded by Ms. Mackey.

In Favor: Malinowski, Pugh, McBride, Livingston, J. Walker, O. Walker, Mackey and English

Not Present: Terracio, Barron and Newton

The vote in favor was unanimous.

- b. An Ordinance Authorizing the acquisition of certain property located in Richland County; and other matters related thereto – Ms. Mackey moved to approve this item, seconded by Mr. J. Walker.

In Favor: Malinowski, Pugh, McBride, Livingston, J. Walker, O. Walker, Mackey and English

Not Present: Terracio, Barron and Newton

The vote in favor was unanimous.

13. **REPORT OF THE CORONAVIRUS AD HOC COMMITTEE**

- a. Proposed grant application and application process – Mr. Brown stated the proposed application is not in the current agenda packet, as it had previously been provided.

Mr. Livingston stated the committee recommended approval of the proposed application.

Ms. McBride moved to move forward with the proposed application and to allow the Administrator and staff to critique or refine the application as they deem necessary, seconded by Mr. Livingston.

Ms. Mackey offered a friendly amendment to have the Administrator bring the application back to Council by August 30th.

In Favor: Malinowski, Pugh, McBride, Livingston, J. Walker, O. Walker, Mackey and English

Not Present: Terracio, Barron and Newton

The vote in favor was unanimous.

Mr. Livingston stated the committee recommended utilizing the discretionary grant process as a basis for evaluation, securing a third-party vendor to evaluate applications for compliance with US Treasury requirements and then forwarding recommendations to the Coronavirus Ad Hoc Committee. The committee also discussed whether there were going to be Council members on the evaluation committee.

Mr. Brown stated, for clarification, the applicant will apply through the Zoom Grants portal. Staff will provide technical assistance, if needed. Applications will be vetted through the third-party vendor. Once vetted, if they are eligible, the applications will go to the “discretionary grant” committee process.

Ms. McBride inquired if the third-party vendor can use a rubric to ensure that the process is as fair as possible. She recommended Council members not be involved in the evaluation and ranking process to ensure the process is not politicized.

Ms. McBride moved to use the external evaluation vendor to develop a rubric, as well as to vet the applications.

Mr. O. Walker stated, for clarification, the request would go through Zoom Grants. Then a third-party vendor would evaluate the request to determine if it comports with US Treasury guidelines. He inquired if the next step in the process would be for the application to be evaluated by staff or a third-party vendor.

Ms. McBride responded the application would be evaluated by the third-party vendor.

Mr. O. Walker inquired if the recommendation should go to Council or the Coronavirus Ad Hoc Committee.

Ms. McBride stated the third-party vendor would evaluate the grants. Council needs to determine if we are going to fund grants ranked 70 or above. She does not have a recommendation on whether it should go to Council or the Coronavirus Ad Hoc Committee.

Mr. O. Walker inquired if we want to include an anonymity feature.

Ms. McBride responded she would hope that would be a part of the process.

Mr. Livingston noted he would like for us to get as much as we can done now so staff can work on something during the month of August.

Mr. Brown stated staff can have the guidelines back to Council by August 30th, but the selection of the vendor will not be complete because it has to go through the RFP process.

Mr. Livingston inquired if the intent of Ms. McBride's motion was for the third-party vendor to also score the applications.

Ms. McBride responded she is suggesting the vendor could assist. She noted the State and Federal government puts out a request for grant reviewers, and they review the grants by utilizing a rubric. If we try to review the applications, it is very subjective. We could use the "discretionary grant" process, but only if we have the rubric in place. Her suggestion would be to exclude Council members from the process.

Ms. Mackey inquired if the intent is for the third-party vendor to rank the applications and then present them to Committee. The committee will make the final decision based on the allotted funding.

Ms. McBride responded that was a part that was missing in the process.

Mr. Livingston noted the committee recommended allowing an organization to apply in up to three (3) categories, but the committee did not recommend an amount.

Ms. English noted she can provide the federal guidelines she utilizes at her job to assist staff with creating guidelines for the application process.

Mr. Brown noted there is recommended evaluation criteria, based on the discretionary grant process, included in the agenda packet.

Ms. McBride moved to forward the recommendations from the Coronavirus Ad Hoc Committee to the Administrator, and staff, for refinement. In addition, the process for evaluation will utilize external evaluators, staff, or others employing a rubric and blind review. Also, Administration will bring back recommendations to the August 30, 2022 Special Called Meeting. Ms. Mackey seconded the motion.

In Favor: Malinowski, Pugh, McBride, Livingston, J. Walker, O. Walker, Mackey and English

Not Present: Terracio, Barron and Newton

The vote in favor was unanimous.

Mr. Livingston stated the committee recommended to allow organizations to apply for funding in up to three categories.

Ms. McBride stated, for clarification, with the committee's recommendation an organization could apply for three separate grants. Therefore, one entity could get up to \$700,000.

Mr. Livingston responded we still have to determine the amount for each grant.

Ms. Mackey stated she supports allowing organizations to apply in more than one category. Some of the organizations may be able to help in more than one category and create an impact in the community.

Mr. Malinowski noted there is a flip side. We need to be willing to spread the wealth and get as much of the funds out to as many organizations as we can.

Ms. Mackey noted the organization can submit the same program in the homeless category, and the mental health category, but they may only get funded out of one category. She does not want us to miss out on a good quality program.

Ms. English inquired if there is a timeframe for when the funds have to be spent.

Mr. Brown responded the timeframe will be imposed by Council.

Ms. English suggested accepting applications between August and December. If we still have funds, then we can come back and do another application period.

In Favor: Pugh, Livingston, O. Walker, Mackey and English

Opposed: Malinowski, McBride and J. Walker

Not Present: Terracio, Barron and Newton

The vote was in favor of the committee's recommendation to allow organizations to apply for funding in up to three categories.

Mr. Livingston stated, for the record, the recommendation for all priority groups who have been allocated funds to date to enter applications upon the portal opening so previously approved funds can be requested for use by the recipients in accordance with grant guidelines was approved during the budget process.

- b. G.A.N.G.S. in Peace Initiative – Mr. Livingston stated this item came before the committee. At that time, the committee felt there was not enough information in reference to the request. The committee requested additional information. The additional information was provided to Council and the matter was placed on the July 12th agenda, wherein it was deferred to the July 19th Council meeting.

Ms. English stated we have always supported improving Richland County in every aspect. It is our goal to improve the County as a whole and to ensure public funds are spent with prudence and foresight. We do not haphazardly enter into agreements based on feelings or emotions. As a mental health counselor, minister, social worker, and psychosocial rehabilitator specialist, she has had the opportunity to work with various agencies. She noted she has advocated for a lot over the last 20 years. As a number of the service agencies and organizations face daily challenges to meet the growing needs of the citizens who require specialized services, she applauds everyone across the County who works to assist others to achieve daily functional living. The program before them has merit and potential to reduce gang interaction. Her concern is the disrespect and personal attacks her colleagues received for asking clarifying questions. The behavior demonstrated at the July 12th Council meeting leaves concern about progressive deportment by program volunteers. Assessment and evaluation are a critically required part of every program. No process can begin without it. Council has often spoken about equity, inclusion and transparency, and we too must adhere to those standards. It is our

responsibility to the citizens of Richland County to ensure the processes of assessment and evaluation are met to definitively justify the expenses. What cannot be tolerated is the level of disrespect from any agency or organization that comes before the body. We want to be good stewards of the funds, and address the needs of many. We thank you for the proposal, applaud your efforts, and understand the need, but it must go through an appropriate process.

Ms. English moved that the G.A.N.G.S. in Peace Initiative go through the appropriate process to be consider for the ARPA funds, seconded by Mr. Malinowski.

Mr. O. Walker stated the narrative that has been put out is Council is callous, does not care about what is happening in the disadvantaged communities and we do not care about individuals that look some of us. We have been politically threatened. He noted this is an initiative that most can support, but at the same time the request is not right for consideration. This is not the same as coming before Council and asking for General Fund. These are federal dollars, which is a separate pot of money. In order to consider requests for those dollars, there has to be a process in place. Even if Council decided to provide funding for the program, the request could not be honored until it is vetted by a third-party vendor to determine whether the program comports with US Treasury guidelines. If the funds are not expended in accordance with the US Treasury guidelines the taxpayers will have to pay the funds back.

In Favor: Malinowski, McBride, Livingston, O. Walker, Mackey and English

Opposed: Pugh, J. Walker

Not Present: Terracio, Barron and Newton

The vote was in favor.

14. **REPORT OF THE ECONOMIC DEVELOPMENT COMMITTEE**

- a. Authorizing the expansion of the boundaries of the I-77 Corridor Regional Industrial Park jointly developed with Fairfield County to include certain property located in Richland County; the execution and delivery of public infrastructure credit agreement to provide for public infrastructure credits to a company identified fir the time being as Project Framework; and other related matters [FIRST READING] – Mr. Livingston stated the committee recommended approval of this item.

In Favor: Malinowski, Pugh, McBride, Livingston, J. Walker, O. Walker and English

Recusal: Mackey (due to her parent company representing the company)

Not Present: Terracio, Barron and Newton

The vote in favor was unanimous.

15. **REPORT OF THE RULES AND APPOINTMENTS COMMITTEE**

- a. NOTIFICATION OF APPOINTMENTS

1. Lexington Richland Alcohol and Drug Abuse Council – Two (2) Vacancies – Mr. Malinowski stated the committee recommended re-appointing Mr. Joshua Douglas Fabel and appointing Salley Rickenbacker Robinson.

In Favor: Malinowski, Pugh, McBride, Livingston, J. Walker, O. Walker, Mackey and English

Not Present: Terracio, Barron and Newton

The vote in favor was unanimous.

**Regular Session
July 19, 2022**

-6-

340 of 343

b. ITEMS FOR ACTION

1. To rename the Discretionary Grants Committee to the Community Impact Grant Committee, and add additional Council members to the committee. This comes from Council's recent budget motion to allocate an additional \$300,000 to the committee and develop a process that creates accountability and transparency [MACKEY – June 21, 2022] – Mr. Malinowski stated the committee recommended approval of this item.

In Favor: Malinowski, Pugh, McBride, Livingston, J. Walker, O. Walker, Mackey and English

Not Present: Terracio, Barron and Newton

The vote in favor was unanimous.

Ms. Mackey noted the Rules and Appointments Committee would like for the Chair to name the additional Council members so the Community Impact Grant Committee can begin work.

2. Disclosure of addresses/personal information of applicants – Mr. Malinowski stated the committee recommended the personal information be removed from the public agenda. The information would continue to be provided to Council members and staff.

In Favor: Malinowski, Pugh, McBride, Livingston, J. Walker, O. Walker, Mackey and English

Not Present: Terracio, Barron and Newton

The vote in favor was unanimous.

16. OTHER ITEMS

- a. FY23 - District 10 Hospitality Tax Allocations – Mr. Pugh moved to approve this item, seconded by Ms. McBride.

In Favor: Malinowski, Pugh, McBride, Livingston, O. Walker, Mackey and English

Opposed: J. Walker

Not Present: Terracio, Barron and Newton

The vote in favor was unanimous.

Mr. Pugh moved to reconsider this item, seconded by Mr. Malinowski.

Opposed: Malinowski, Pugh, McBride, Livingston, J. Walker, O. Walker, Mackey and English

Not Present: Terracio, Barron and Newton

The motion for reconsideration failed.

17. EXECUTIVE SESSION – There were no items for Executive Session.

18. MOTION PERIOD – There were no motions submitted.

19. ADJOURNMENT – Mr. Pugh moved to adjourn, seconded by Ms. McBride.

In Favor: Malinowski, Pugh, McBride, Livingston, J. Walker, O. Walker, Mackey and English

**Regular Session
July 19, 2022**

-7-

Not Present: Terracio, Barron and Newton

The vote in favor was unanimous.

The meeting adjourned at approximately 7:52 PM.

STATE OF SOUTH CAROLINA)
)
COUNTY OF RICHLAND)

**A RESOLUTION OF THE
RICHLAND COUNTY COUNCIL**

**A RESOLUTION TO APPOINT AND COMMISSION MICHAEL BRENT DAVIS
AS A CODE ENFORCEMENT OFFICER FOR THE PROPER SECURITY,
GENERAL WELFARE, AND CONVENIENCE OF RICHLAND COUNTY.**

WHEREAS, the Richland County Council, in the exercise of its general police power, is empowered to protect the health and safety of the residents of Richland County; and

WHEREAS, the Richland County Council is further authorized by Section 4-9-145 of the Code of Laws of South Carolina 1976, as amended, to appoint and commission as many code enforcement officers as may be necessary for the proper security, general welfare, and convenience of the County;

NOW, THEREFORE, BE IT RESOLVED THAT Michael Brent Davis is hereby appointed and commissioned a Code Enforcement Officer of Richland County for the purpose of providing for the proper security, general welfare, and convenience of the County, replete with all the powers and duties conferred by law upon constables, in addition to such duties as may be imposed upon him by the governing body of this County, including the enforcement of the County’s animal control regulations, and the use of an ordinance summons, and with all the powers and duties conferred pursuant to the provisions of Section 4-9-145 of the Code of Laws of South Carolina 1976, as amended. Provided, however, Michael Brent Davis shall not perform any custodial arrests in the exercise of his duties as a code enforcement officer. This appointment shall remain in effect only until such time as Michael Brent Davis is no longer employed by Richland County to enforce the County’s animal control regulations.

ADOPTED THIS THE 1ST DAY OF NOVEMBER, 2022.

Overture Walker, Chair
Richland County Council

Attest: _____
Anette Kirylo
Clerk of Council